



VANGUARD PAI LUNG



MODELS: SJ4AC/D, DI, DI2, DI3 & SJ3AC/D, DI, DI2, DI3, DL & Titan

PARTS CATALOG

Titan 3590_02_, Revision F



Table of Contents

SECTION 1. FRAME ASSEMBLY	<u>11</u>
SECTION 2. ELECTRICAL ASSEMBLY	<u>33</u>
SECTION 3. OIL AND AIR DISTRIBUTION ASSEMBLY	<u>45</u>
SECTION 4. TAKEUP ASSEMBLY	<u>49</u>
SECTION 5. FEEDER DRIVE SYSTEM	<u>111</u>
SECTION 6. CENTER SHAFT AND SPREADER ASSEMBLYS	<u>116</u>
SECTION 7. KNITTING ELEMENTS	<u>123</u>
SECTION 8. FILTER FLOW 2000	<u>135</u>
SECTION 9. MACHINE SPECIFICATIONS	<u>140</u>

Fourth Edition, Revision D (September 2012)

This edition applies to the Vanguard Pai Lung SJAC/D and DL circular knitting machines. Changes are periodically made to the information herein; any such changes will be reported in subsequent editions or technical bulletins.

The information contained herein does not imply to cover all details or variations of machinery in connection with maintenance. Should further information be required, contact the Vanguard Pai Lung Customer Service Department for assistance. This publication could contain technical inaccuracies or typographical errors.

Vanguard Pai Lung, claims proprietary rights to the material disclosed herein. This publication may not be reproduced in whole or in part without written permission from VPL or a subsidiary or affiliated company authorized by VS to give such permission.

Requests for VPL publications should be made to your local VPL representative or to VPL at the address below:

Vanguard Pai Lung

601 Mac Arthur Circle

P.O. Box 9

Monroe, NC 28111-5009 U.S.A.

Phone: 704/283-8171 Toll Free: 800/222-1971 Fax: 704/283-9257

Or find us on the World Wide Web @ <http://vanguardpailung.com>



SAFETY NOTICE - NEW STYLE LABELING

The following pictograms represent safety procedures for various countries and economic communities around the world. Read and understand the various warnings and procedures in this manual before operating or repairing the machine.

⚠ WARNING ⚠ AVISO	
	<p>HAZARD FROM ROTATING PARTS. SERIOUS INJURY OR DEATH CAN OCCUR.</p> <ul style="list-style-type: none"> Σ TURN OFF MAIN POWER BEFORE OPENING SAFETY GATES. Σ OPERATE MACHINE ONLY WITH SAFETY GATES SECURELY CLOSED AND LATCHED. Σ DO NOT ATTEMPT TO COMPROMISE OPERATION OR INSTALLATION OF SAFETY DEVICES. Σ LOCKOUT/TAGOUT MAIN POWER PRIOR TO SERVICING THIS EQUIPMENT. <hr/> <p>PELIGRO DE PARTES GIRATORIAS. PUEDE OCASIONAR GRAVES LESIONES O LA MUERTE.</p> <ul style="list-style-type: none"> Σ APAGAR LA CORRIENTE PRINCIPAL ANTES DE ABRIR LAS PUERTAS DE SEGURIDAD. Σ HACER FUNCIONAR LA MÁQUINA SÓLO CON LAS PUERTAS DE SEGURIDAD CERRADAS. Σ NO INTENTAR CAMBIAR O ANULAR LOS MECANISMOS DE SEGURIDAD. Σ Bloquear y etiquetar la corriente principal antes de reparar este equipo.

⚠ WARNING ⚠ AVISO	
 	<p>HAZARD FROM ROTATING PARTS. SERIOUS INJURY OR DEATH CAN OCCUR.</p> <ul style="list-style-type: none"> Σ TURN OFF MAIN POWER BEFORE OPENING SAFETY GATES. Σ OPERATE MACHINE ONLY WITH SAFETY GATES SECURELY CLOSED AND LATCHED. Σ DO NOT ATTEMPT TO COMPROMISE OPERATION OR INSTALLATION OF SAFETY DEVICES. Σ LOCKOUT/TAGOUT MAIN POWER PRIOR TO SERVICING THIS EQUIPMENT. <hr/> <p>PELIGRO DE PARTES GIRATORIAS. PUEDE OCASIONAR GRAVES LESIONES O LA MUERTE.</p> <ul style="list-style-type: none"> Σ APAGAR LA CORRIENTE PRINCIPAL ANTES DE ABRIR LAS PUERTAS DE SEGURIDAD. Σ HACER FUNCIONAR LA MÁQUINA SÓLO CON LAS PUERTAS DE SEGURIDAD CERRADAS. Σ NO INTENTAR CAMBIAR O ANULAR LOS MECANISMOS DE SEGURIDAD. Σ Bloquear y etiquetar la corriente principal antes de reparar este equipo.

⚠ WARNING ⚠ AVISO	
  	<p>HAZARD FROM ELECTRIC SHOCK. SERIOUS INJURY OR DEATH CAN OCCUR.</p> <p>ENCLOSURE CONTAINS: 460 VAC, 3 PHASE, 50/60 HZ CIRCUITS</p> <ul style="list-style-type: none"> Σ ONLY QUALIFIED SERVICE PERSONNEL TO ACCESS THIS ELECTRICAL ENCLOSURE. Σ LOCKOUT/TAGOUT SUPPLY DISCONNECTING DEVICE PRIOR TO SERVICING ELECTRICAL ENCLOSURE. <hr/> <p>PELIGRO DE DESCARGA ELÉCTRICA. PUEDE OCASIONAR GRAVES LESIONES O LA MUERTE.</p> <p>Esta área eléctrica contiene: 230 VAC, 3 FASES, 50/60 HZ CIRCUITOS</p> <ul style="list-style-type: none"> Σ Sólo el personal de servicio debidamente capacitado debe tener acceso a estas áreas eléctricas. Σ Bloquear y etiquetar el dispositivo desconectador de suministro de energía antes de efectuar servicio en estas áreas eléctricas.

NOTE: Machine safety signs and labels shall periodically be inspected and cleaned by the operator to maintain good legibility. Replace machine safety signs and labels when they are no longer legible. Replacement safety signs and labels are available through Vanguard Pai Lung or through the local machine agent.

SAFETY NOTICE - NEW STYLE LABELING (continued)

The following pictograms represent safety procedures for various countries and economic communities around the world. Read and understand the various warnings and procedures in this manual before operating or repairing the machine.

⚠ WARNING ⚠ AVISO



HAZARDOUS VOLTAGE EXISTS INSIDE ENCLOSURE WITH MAIN POWER SWITCH OFF.

EXISTE TENSIÓN PELIGROSA DENTRO DE LA CAJA CON EL INTERRUPTOR DE ENERGÍA PRINCIPAL APAGADO.

⚠ WARNING ⚠ AVISO



HAZARD FROM FLYING DEBRIS. SERIOUS EYE INJURY CAN OCCUR.

Σ SAFETY GLASSES MUST BE WORN WHEN NEAR AN OPERATING MACHINE.

PELIGRO DE MATERIAL VOLANTE. PUEDE PRODUCIR GRAVES HERIDAS EN LOS OJOS.

Σ HAY QUE USAR LENTES DE SEGURIDAD EN LAS CERCANIAS DE UNA MAQUINA EN MARCHA.

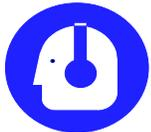

HAZARD FROM AIRBORNE NOISE. SERIOUS EAR INJURY CAN OCCUR.

Σ HEARING PROTECTION MUST BE WORN WHEN NEAR AN OPERATING MACHINE.

PELIGRO DE RUIDO EXCESIVO. PUEDE PRODUCIRSE GRAVES HERIDAS EN LOS OIDOS.

Σ HAY QUE USAR PROTECCION ACUSTICA (OREJERAS) EN LAS CERCANIAS DE UNA MAQUINA EN MARCHA.



READ AND UNDERSTAND THE OPERATOR'S MANUAL BEFORE USING THIS MACHINE.

Σ FAILURE TO FOLLOW THE OPERATING INSTRUCTIONS COULD RESULT IN DEATH OR SERIOUS INJURY.

ASEGÚRENSE DE LEER Y ENTENDER EL MANUAL DEL OPERADOR ANTES DE USAR ESTA MÁQUINA.

Σ LA FALTA DE SEGUIR LAS INSTRUCCIONES OPERACIONALES PUEDE RESULTAR EN LA MUERTE O HERIDAS SERIAS.

⚠ CAUTION ⚠ ¡CUIDADO!



HOT SURFACE. DO NOT TOUCH.

TO AVOID POSSIBLE SKIN BURNS, ALLOW SURFACE TO COOL BEFORE SERVICING.

SUPERFICIE CALIENTE. ¡NO TOCAR!

Paraevitar quemaduras en la piel, permita que la superficiese enfré antes del servicio.

NOTE: Machine safety signs and labels shall periodically be inspected and cleaned by the operator to maintain good legibility. Replace machine safety signs and labels when they are no longer legible. Replacement safety signs and labels are available through Vanguard Pai Lung or through the local machine agent.

SAFETY NOTICE - NEW STYLE LABELING (continued)

The following pictograms represent safety procedures for various countries and economic communities around the world. Read and understand the various warnings and procedures in this manual before operating or repairing the machine.

NOTICE AVISO



MAIN POWER. MACHINE LOCKOUT POINT.

CORRIENTE PRINCIPAL. Lugar de bloqueo y etiquetado de la máquina.

NOTICE AVISO



Contact with oil can result in defatting of the skin and in certain cases irritation can develop from sensitivity. Consult the MSDS and/or Technical Data Sheet supplied with the lubricating oil for first aid procedures and recommended personal protective equipment.

El contacto con resultado de la lata de aceite en defatting de la piel y en cierta irritación de los casos puede convertirse de sensibilidad. Consulte el MSDS y/o la hoja de datos técnica provistos del aceite lubricante para los procedimientos de los primeros auxilios y el equipo protector personal recomendado.

NOTE: Machine safety signs and labels shall periodically be inspected and cleaned by the operator to maintain good legibility. Replace machine safety signs and labels when they are no longer legible. Replacement safety signs and labels are available through Vanguard Pai Lung or through the local machine agent.

SAFETY NOTICE - OLD STYLE LABELING

The following pictograms represent safety procedures for various countries and economic communities around the world. Read and understand the various warnings and procedures in the operator's manual before operating the machine.

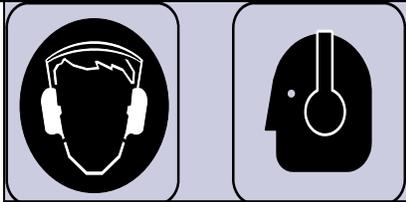

WARNING:
HAZARD FROM AIRBORNE NOISE
SERIOUS EAR INJURY CAN OCCUR
HEARING PROTECTION MUST BE WORN WHEN
NEAR AN OPERATING MACHINE

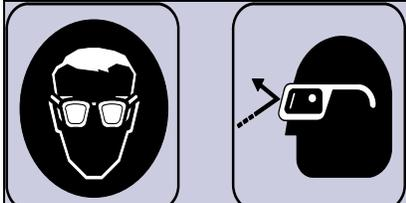

WARNING:
HAZARD FROM FLYING DEBRIS
SERIOUS EYE INJURY CAN OCCUR
SAFETY GLASSES MUST BE WORN WHEN
NEAR AN OPERATING MACHINE

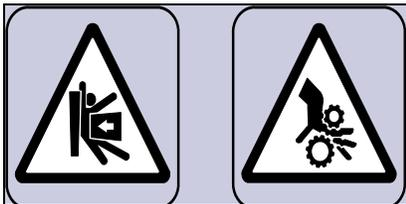

WARNING:
HAZARD FROM ROTATING PARTS
SERIOUS INJURY OR DEATH CAN OCCUR

- * TURN OFF MAIN POWER BEFORE OPENING SAFETY GATES OR REMOVING COVERS.
- * OPERATE MACHINE ONLY WITH SAFETY GATES SECURELY CLOSED AND LATCHED.
- * DO NOT ATTEMPT TO COMPROMISE OPERATION OR INSTALLATION OF SAFETY DEVICES.
- * KEEP HANDS, JEWELRY, CLOTHING, AND HAIR AWAY FROM ROTATING PARTS.

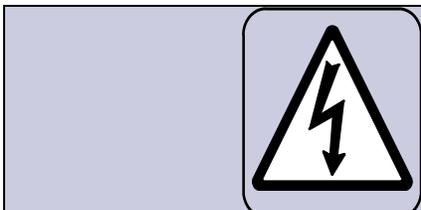

WARNING:
HAZARD FROM ELECTRIC SHOCK
SERIOUS INJURY OR DEATH CAN OCCUR

- * ONLY QUALIFIED SERVICE PERSONNEL TO ACCESS THIS ELECTRICAL ENCLOSURE
- * LOCK OUT SUPPLY DISCONNECTING DEVICE BEFORE SERVICING ELECTRICAL ENCLOSURE.

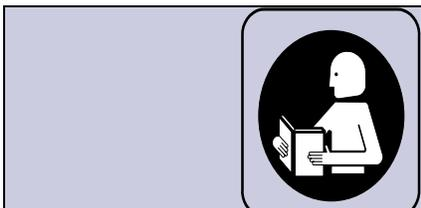

WARNING:
GENERAL HAZARD, SERIOUS INJURY OR SEVERE DAMAGE TO THE MACHINE CAN OCCUR
READ AND UNDERSTAND THE PROCEDURES
IN THE OPERATOR'S MANUAL BEFORE

NOTE: Machine safety signs and labels shall periodically be inspected and cleaned by the operator to maintain good legibility. Replace machine safety signs and labels when they are no longer legible. Replacement safety signs and labels are available through Vanguard Pai Lung or through the local machine agent.

SAFETY CHECKLIST

Use the following recommended safety checklist to inspect the safety components and the controls on the machine after each operator change or shift change to insure your safety. Failure to inspect and reduce the potential hazards caused by use, modifications, or failures of safety components and controls on a regular schedule can result in severe injury or death. Do not operate the machine if any of the following items are not in place or operating properly. Replacement parts are available through Vanguard Supreme or your local agent. See the *Parts Manual* supplied with your machine for information on ordering parts.

Warning: Some items on this checklist require the main power to be turned on. Insure all safety devices are properly installed and operating before turning on the main power.

Recommended Safety Checklist

- Safety gates are in place and operate properly.
- Safety gate switches are in place and operate properly.
- Safety gate latches are in place and latch securely.
- Motor cover is in place and fastened securely.
- Motor cover switch is in place and operates properly.
- Fixed covers are in place and fastened securely.
- Safety labels are in place and are legible.
- Air lines and oil lines are in place and connected securely.
- Take up swing arm latches operate properly and latch securely.
- Take up swing arm micro switches operate properly.
- Cloth fallout detector operates properly.
- Operator panel display operates properly
- Reset button illuminates and operates properly.
- Stop, start, and jog buttons operate properly
- Red stop motion lights operate properly.
- Power supply cover is closed and locked.
- Any addition guards required by local codes are in place and operate properly.

Ordering Instructions

When ordering parts for your Vanguard Supreme Circular Knitting Machine, please include the following information:

*Machine Model

*Needle Gauge

*Machine Serial Number

*Part Number of Item Needing Replacement

*Cylinder Diameter and Cut

*Description of Item Needing Replacement

Do not use the item or page numbers from this manual except as additional information.

Each page of this parts manual identifies:

<p><u>A</u> Item Number for an Assembly</p> <p><u>B</u> Item Number for a Part</p> <p><u>C</u> Assembly Name</p>	<p><u>D</u> Part Name</p> <p><u>E</u> Assembly Number</p> <p><u>F</u> Part Number</p>
---	--

* If a part number is not available for an assembly or an individual part, "No P/N" will appear in the part no. column. Order the individual part if the assembly does not have a part number. Order the assembly if the individual part does not have a part number.

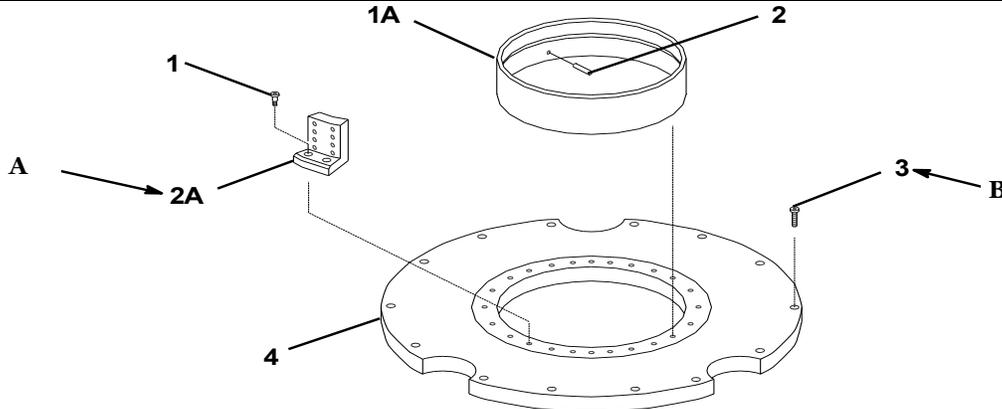

	ITEM	PART NUMBER	DESCRIPTION
	1A	Specify Dia & Cut	Inserted Cylinder Assembly
A →	2A	117344-DIA	Section Block Assembly ← C
			(See Figure 8 for Illustrated Parts Breakdown.)
F →	1	7769	Shoulder Screw
	2	805354	Dowel Pin
	3	6426	Socket Head Cap Screw 1/4-20 x 1 1/4 ← D
B →	4	No P/N	Cam Retaining Ring



Model SJAC/D

Circular Knitting Machine

SECTION 1. FRAME ASSEMBLY

	<u>Page</u>
Figure 1 Final Frame Assembly	<u>12</u>
Figure 1A Mechanical Quality Wheel Assembly	<u>14</u>
Figure 2 Cam Ring and Gear Ring Assembly (New Style) . . .	<u>16</u>
Figure 3 Cam Ring and Gear Ring Assembly (Old Style)	<u>18</u>
Figure 4 Frame Assembly	<u>20</u>
Figure 5 Gate Assembly	<u>24</u>
Figure 6 Drive Assembly with Oil Return.....	<u>28</u>
Figure 7 Motor Mounting Assembly	<u>30</u>

NOTICE

SJ4AC/D, DI, DI2, SJ3AC/D and DL

Group Number Represents Machine Diameter:

31" thru 36"	Group 5
26" thru 30"	Group 0
21" thru 25"	Group 1
16" thru 20"	Group 2
11" thru 15"	Group 3

SJ4AC/DI3

16" thru 20"	Group 1
11" thru 15"	Group 2

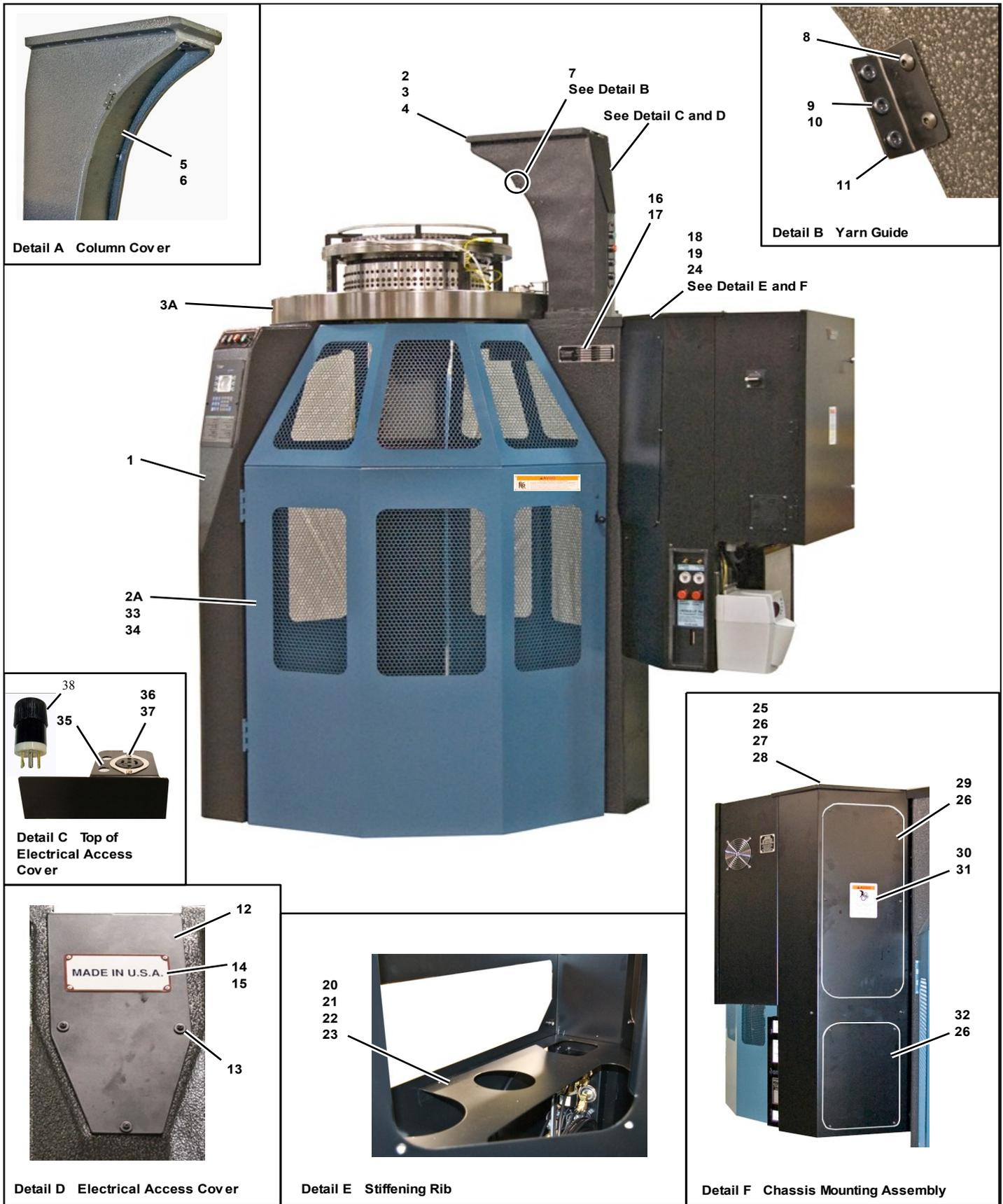
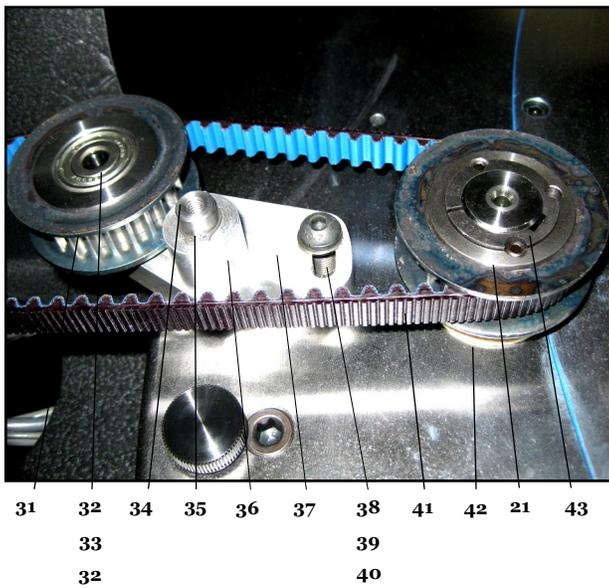
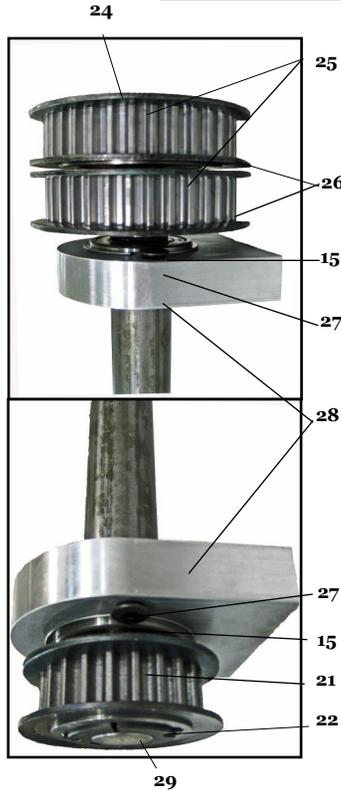
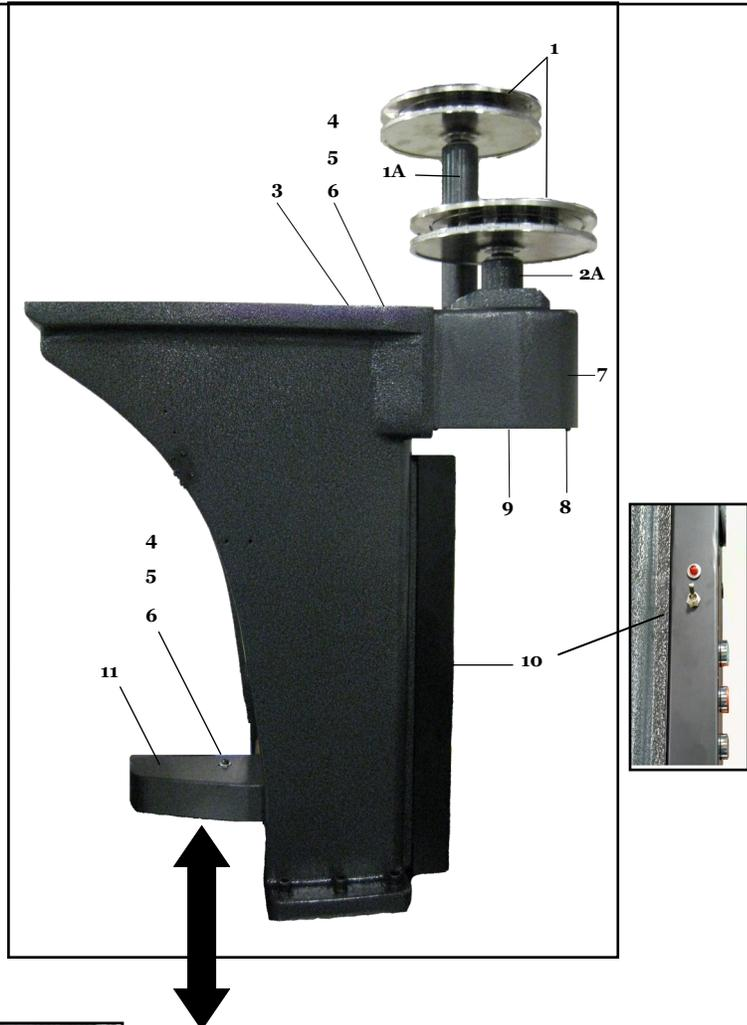
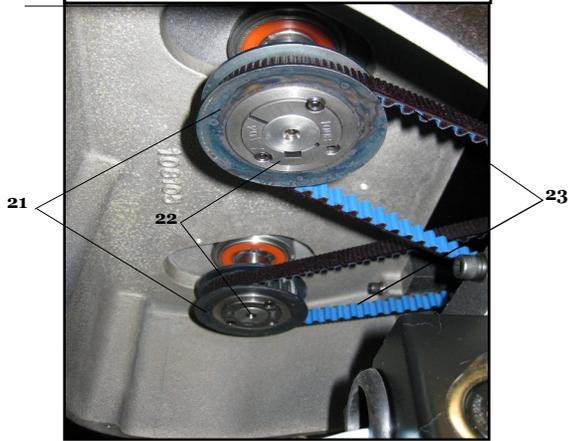
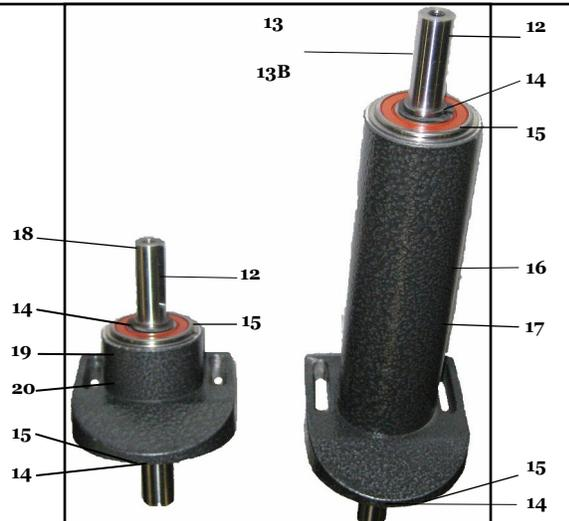

Figure 1. Final Frame Assembly

Item	Part Number	Description
1A	119015-1GP 119015-GP 119015-2GP	Final Frame Assembly Jumbo Height Industrial Height Standard Height
2A	119016-1GP 119016-GP 119016-2GP	Gate Assembly Jumbo Height Industrial Height Standard Height See Figure 5. For Illustrated Parts Breakdown
3A	No P/N	Cam Ring and Gear Ring Assembly See Figures 2. and 3. For Illustrated Parts Breakdown
1	No Part Number	Frame Assembly See Figure 4. for Illustrated Parts Breakdown
2	106789-01	Drive Column
3	806584-12055	Socket Head cap Screw, M12 x 1.75 x 55 mm
4	806597-12	Lock Washer, M12
5	106931	Column Cover
6	806587-04008	Socket Head Cap Screw, M4 x .7 x 8 mm
7	117339-01	Yarn Guide Assembly Includes Items 8 thru 11
8	806584-04008	Socket Head Cap Screw, M4 x .7 x 8 mm
9	1806137	Ceramic Guide
10	104690-01	Rubber Retaining Ring
11	105865	Bracket
12	106929	Electrical Access Cover
13	806584-04008	Socket Head Cap Screw, M4 x .7 x 8 mm
14	806178-518	Made in USA Label
15	806973-03	Blind Rivet
16	806178-515	Serial Plate
17	806490-02	Drive Screw
18	119038	Chassis Mounting Assembly Includes Items 19 thru 23
19	106787	Chassis
20	106927	Stiffening Rib
21	806584-06012	Socket Head Set Screw, M6 x 1 x 12 mm
22	806597-06	Lock Washer, M12
23	806596-06	Flat Washer, M12
24	1806283	Serrated Flange Hex Screw
25	106883	Top Cover
26	806587-06012N	Button Head Cap Screw, M6 x 1 x 12 mm Nylok
27	806597-06	Lock Washer, M6
28	7814	Flat Washer, 1/4"
29	106926	Motor Access Cover
30	806178-502	Entanglement Label
31	806973-03	Blind Rivet
32	106926-01	Filter Flow Access Cover
33	806587-06016	Button Head Cap Screw, M6 x 1 x 16 mm
34	806597-06	Lock Washer, M6
35	7796	Grommet
36	775512	Receptacle
37	806587-04010	Button Head Cap Screw, M4 x .7 x 10 mm
38	7764	Fan Plug, Male

Mechanical Quality Wheel Drive 1A



Titan 3590_02_, Revision F

Item	Part Number	Description
1	807587	Single Quality Wheel
	807605	Double Quality wheel
1A	WE91308B-010	Quality Wheel Assembly (Upper)
2A	WE91308B-020	Quality Wheel Assembly (Lower)
3	108115	Cover Housing
4	806587-06016	Button Head Screw M6X16
5	806606-06	M6 Lock Washer
6	006345	#10 Flat Washer
7	119044-01	Housing and Towers
8	806587-04012	Screw M4 X 12
9	108152	Cover
10	108162	Housing Cover (Feeder Override Kit-119124), (Toggle Switch-775006-05),(Indicator Light-775067)
11	108073-02	Cover
12	806610-0505640	Key
13	WE91333B-010	Shaft (Tall) (Shaft for Lycra, 3" Longer WE91333B-030)
14	807703-01	Snap Ring
15	806190	Bearing
16	WE91274-32	Spacer (Tall)
17	WE91308A-01	Quality Wheel Housing (Tall)
18	WE91333B-020	Shaft (Short)
19	WE91274-33	Spacer (Short)
20	WE91308A	Housing Short
21	806677-22	Sprocket 22T
22	806697-20	Bushing TL
23	806670-640	Belt
24	806602-06050	Key 50mm
25	1806187-20	Bushing TL (2 Per)
26	806677-34	Sprocket 34T (2 Per)
27	806586-06012	Screw
28	108060-01	Block, Quality Wheel Bearing
29	806602-06022	Key 22mm
30	108061	Drive Shaft , Quality Wheel
31	806677-22 PBA	22T Pulley
32	WE65012	Bearing (2 Per)
33	108072-01	Post
34	108102	Post
35	806192-050	Snap Ring
36	108101-2	Post
37	108101-1	Arm
38	806587-08030	Button Head Screw
39	806596-08	Flat Washer
40	806597-08	Lock Washer
41	806670-720	Belt
42	104891-01	Felt Pad
43	806697-25	Bushing TL
	119123-OLDGP	CONVERSION from IRO Motor Drive to Mechanical Quality Wheel Drive (Old Drive Column) Additional items: 807746-Cap 2 Wire Cable, 775380-25 Transformer Cont. 775622-01- PCB Cont. 775622-02-PCB VAC Fluor Dspl.

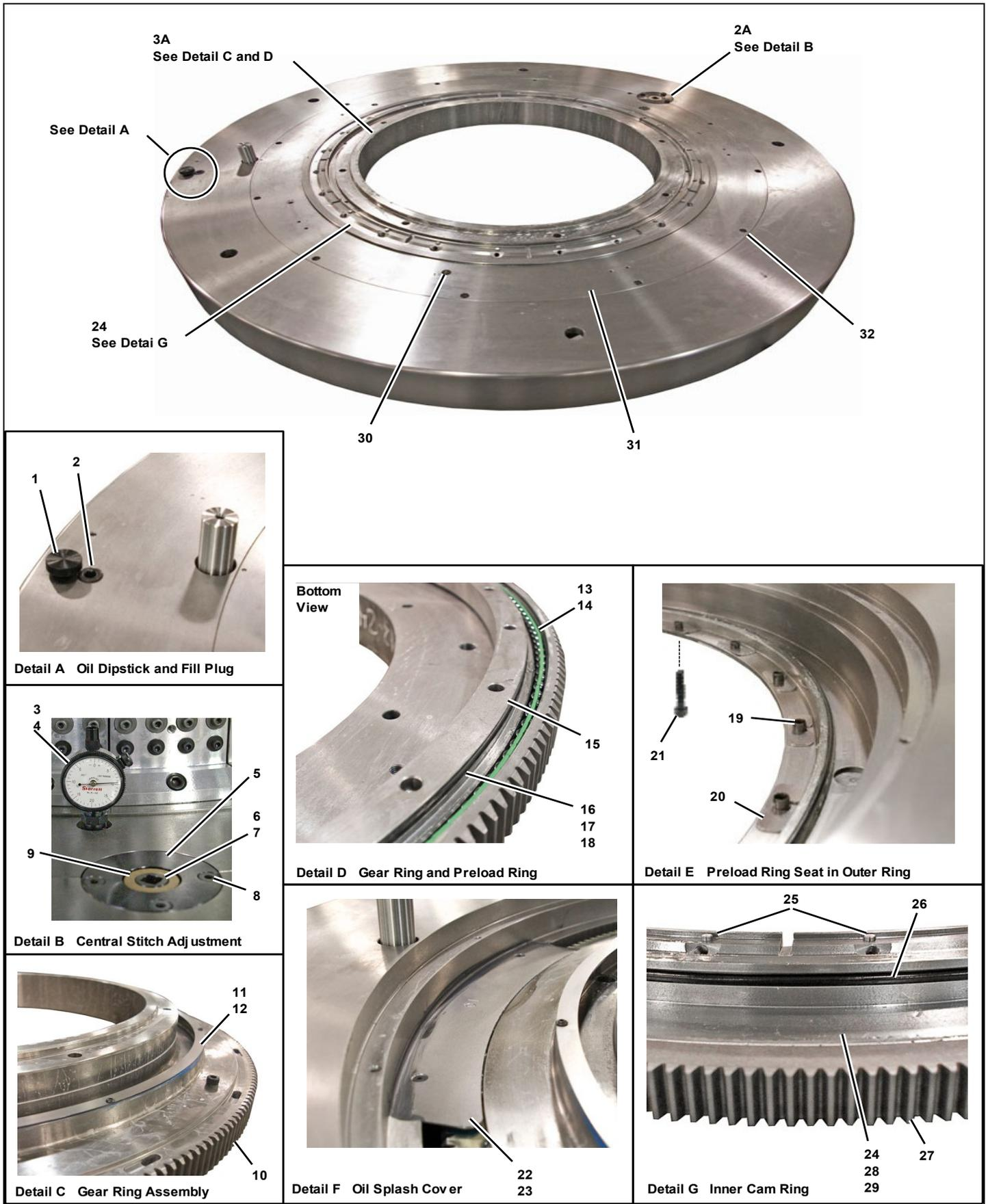

Figure 2. Cam Ring and Gear Ring Assembly (New Style)

Item	Part Number	Description
1A	No P/N	Cam Ring and Gear Ring Assembly (New Style) See Figure 1.-3A For Next Higher Assembly
2A	118931-01	Indexing Housing Pinion Assembly Includes Items 5 thru 9
3A	119020-1DIA	Gear Ring Assembly Includes Items 10 thru 12
1	108037A	Oil Level Dipstick
2	805471-3	Pipe Plug, 3/8-18 NPT x 5/16"
3	806396-06	Dial Indicator
4	1806046	Collet
5	103512-01	Housing
6	103511	Indexing Pinion
7	806574-02	Spring Washer (Not Shown)
8	806586-06020	Countersink Socket Head Cap Screw, M6 x 1 x 20 mm
9	806454-03	Flanged Bushing
10	108042-DIA	Gear Ring
	108189-DIA	SJ4AC/DI3 Gear Ring
11	108047-DIA	Oil Retaining Cover
12	806587-04006	Button Head Cap Screw, M4 x .7 x 6 mm
13	1806317-1GPH	Wire Ball Race (Includes Plastic Bearing Cage)
14	1806303-375	Ball Bearing, 3/8" Ball Bearing (Quantity: 11" to 15"=142, 16" to 20"=174, 21" to 24"=205 26" to 30"=237)
15	108043-GP	Bearing Preload Ring
16	1806318-GP	O-Ring
17	1806247-1020	Shim Band (Not Shown) (Use Loctite Instant Gasket, P/N 806385-13, to Hold Shim Band in Place)
18	806973-01	Pop Rivet (Not Shown)
19	1806272-01	Spring Alignment Dowel
20	119091-GPKIT	Outer Ring Shim Kit
	005997-A	0.005" Thick
	005997	0.010" Thick
	005998	0.015" Thick
	005998-B	0.0375" Thick
	005998-A	0.040" Thick
	005998-D	0.036" Thick
21	806584-08035N	Socket Head Cap Screw, M8 x 1.25 x 35 mm Nyloc
22	108044-GP	Oil Splash Cover
23	806586-04012	Countersink Socket Head Cap Screw, M4 x .7 x 12 mm
24	108046-DIA	Inner Cam Retaining Ring
	108190-DIA	SJ4AC/DI3 Inner Cam Retaining Ring
25	106017-01	Step Pin
26	1806319-DIA	O-Ring
27	106797-1GP	Indexing Ring
28	1806247-020	Shim Band (Not Shown) (Use Loctite Instant Gasket, P/N 806385-13, to Hold Shim Band in Place)
29	806973-01	Pop Rivet (Not Shown)
30	806574-12036	Dowel Pin
31	106798-1DIA	Outer Cam Retaining Ring
	108191-DIA	SJ4A/DI3 Outer Cam Retaining Ring
32	806584-06025	Socket Head Cap Screw, M6 x 1 x 25 mm

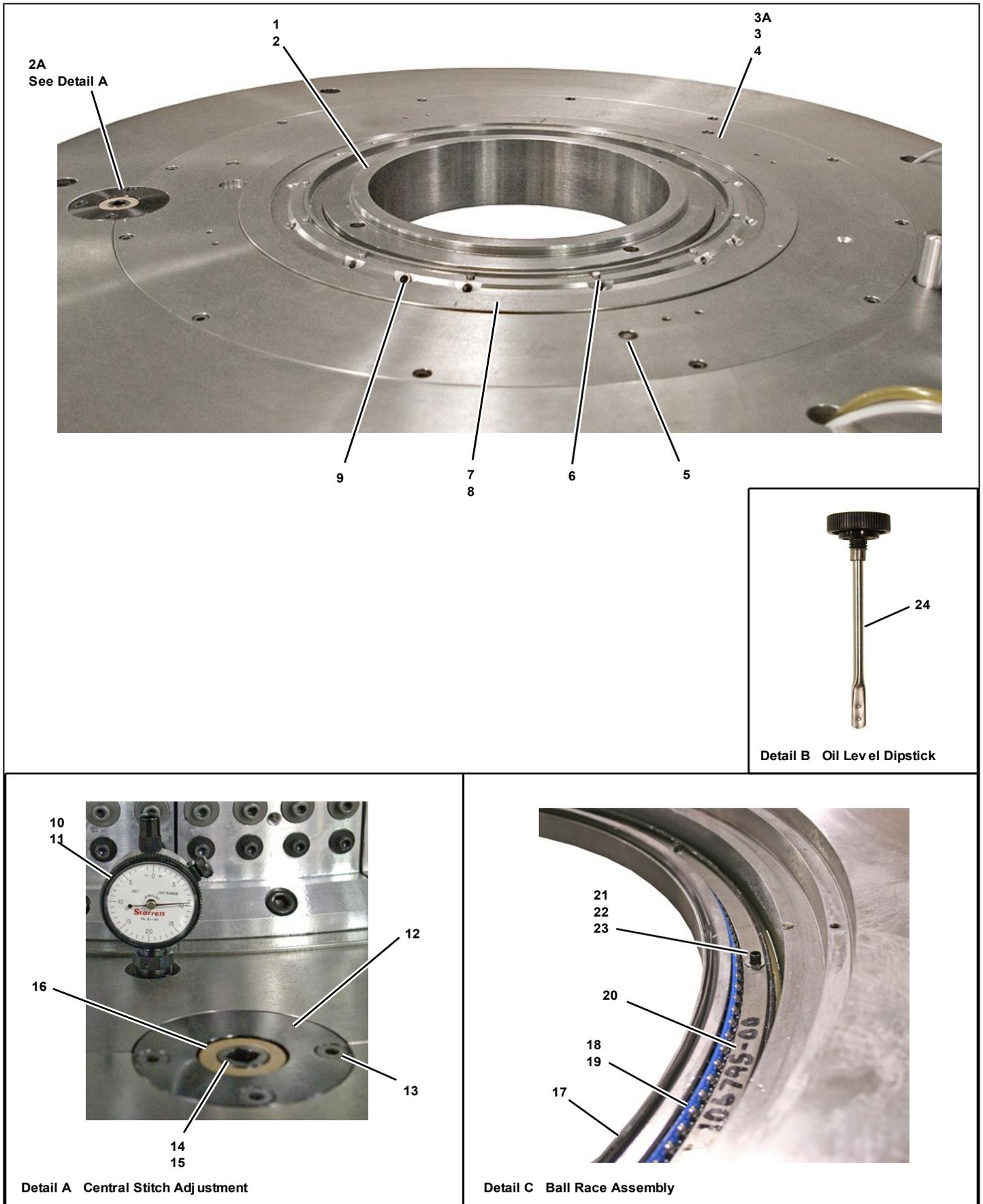

Figure 3. Cam Ring and Gear Ring Assembly (Old Style)

Item	Part Number	Description
1A	No P/N	Cam Ring and Gear Ring Assembly (Old Style) See Figure 1.-3A For Next Higher Assembly
2A	118931-01	Indexing Housing Pinion Assembly Includes Items 12 thru 16
3A	119009-1DIA	Cam Ring Assembly Includes Items 3 thru 16
	119009-3DIA	Ring Cam Rtng Ring Kit CS-SJ4AC/DI3 (11"-20" Only)
1	106772-DIA	Gear Ring
2	805471-3	Pipe Plug, 3/8-18 NPT x 5/16"
3	106798-130	Outer Cam Retaining Ring
4	806584-06025	Socket Head Cap Screw, M6 x 1 x 25 mm
5	806574-12036	Dowel Pin, M12 x 36 mm
6	106017-01	Step Pin
7	106796-1DIA	Inner Cam Retaining Ring
8	106797-1GP	Indexing Ring (Not Shown)
9	106937	Oil Drain Tube
10	806396-06	Dial Indicator
11	1806046	Collet
12	103512-01	Housing
13	806586-06020	Countersink Socket Head Cap Screw, M6 x 1 x 20 mm
14	103511	Indexing Pinion
15	806574-02	Spring Washer (Not Shown)
16	806454-03	Flanged Bushing
17	1806273	Rubber Seal
18	1806303-375	Ball Bearing (Quantity: 11" to 15"=142, 16" to 20"=174, 21" to 24"=205 26" to 30"=237) Must Order Item 19 When Replacing Ball Bearings
19	1806270-GP	Wire Bearing Race and Ball Bearing Cage Set Must Order Item 18 When Replacing Wire Bearing Race and Ball Bearing Cage
20	106795-GP	Bearing Preload Ring
21	806584-06025N	Socket Head Cap Screw, M6 x 1 x 25 mm Nylok
22		Bearing Preload Shim
	106899-031	0.031" Thick
	106899-020	0.020" Thick
	106899-006	0.006" Thick
	106899-004	0.004" Thick
23	1806272	Spring Alignment Dowel Bushing
24	108037Y	Oil Level Dipstick

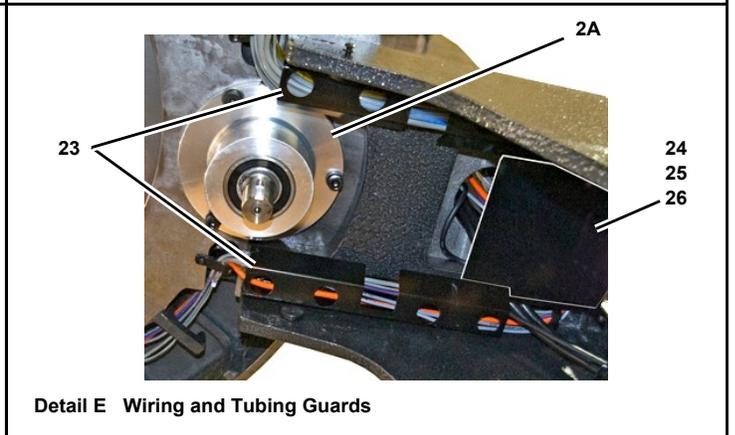
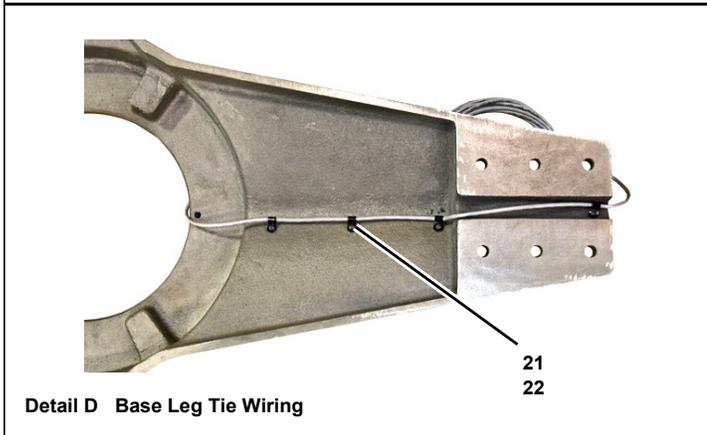
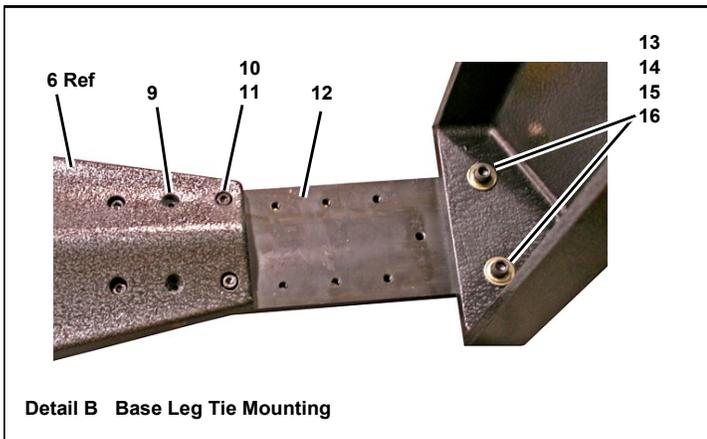
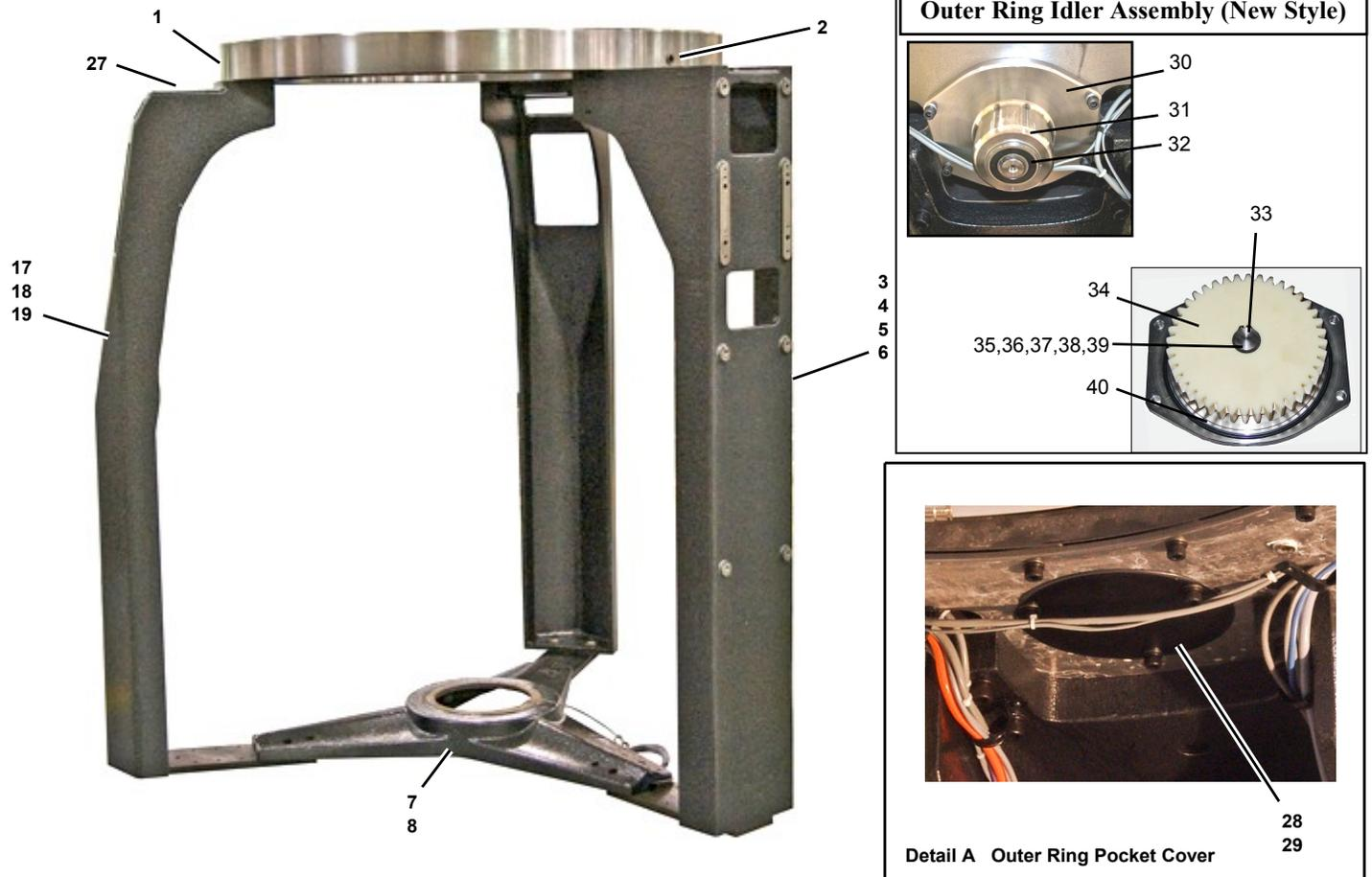

Figure 4. Frame Assembly

Item	Part Number	Description
1A	No P/N 119110-4TAB	Frame Assembly For Next Higher Assembly, See Figure 1.-1 Frame SJ4AC/DI3 (-401QW and -401MOT)
2A	119024-02	Drive Assembly with Oil Return See Figure 6. For Illustrated Parts Breakdown
1	106771-GP	Outer Ring
2	805471-5	Pipe Plug, 3/4-14 NPT x 9/16" Socket Head
3		Drive Leg
	106773-01	Jumbo Height Frame
	106773-02	Industrial Height Frame
	106773-03	Standard Height Frame
4	806596-12	Flat Washer, M12
5	806584-12055	Socket Head Cap Screw, M12 x 1.75 x 55 mm
6	806597-12	Lock Washer, M12
7	106793-GP	Base Leg Tie
8	806590-1050	Socket Head Set Screw, M10 x 1.5 x 50 mm
9	806586-10035	Countersink Socket Head Cap Screw, M10 x 1.5 x 35 mm
10	806584-10040	Socket Head Cap Screw, M10 x 1.5 x 40 mm
11	806597-10	Lock Washer, M10
12	106871	Support Pad
13		Socket Head Cap Screw
	806584-12050	M12 x 1.75 x 50 mm, Used on Drive Leg
	806584-12045	M12 x 1.75 x 45 mm, Used on Plain Leg
14	1806243-02	Flat Washer, 1/2" USS Grade 8
15	1806243-01	Flat Washer, 1/2" SAE Grade 8
16	806597-12	Lock Washer, M12
17		Plain Leg
	106774-01	Jumbo Height Frame
	106774-02	Industrial Height Frame
	106774-03	Standard Height Frame
18	806584-12055	Socket Head Cap Screw, M12 x 1.75 x 55 mm
19	806597-12	Lock Washer, M12
20	805471	Magnetic Pipe Plug, 3/8-18 NPT x 5/16 Socket Head
21	775516-04	Cable Clamp, 1/4" Loop
22	806587-04008	Button Head Cap Screw, M4 x .7 x 8 mm
23	106596	Wire Bundle Cover
24	106991	Wire and Tubing Guard
25	806584-04010	Socket Head Cap Screw, M4 x .7 x 10 mm
26	806597-04	Lock Washer, M4
27	1806314	Hole Plug
28	108045-01	Cover
29	806584-08016	Socket Head Cap Screw, M8 x 1.25 x 16 mm
30	119112	Idler Assembly
	119112-01	Idler Assembly Note: These Are After Serial Numbers 54637
31	108153	Housing, Idler SJ4AC/D
32	1806361	Bearing, MTRC
33	108154	Shaft, Idler
34	108155	Gear, Idler, Nylon
35	1806360	Bearing, MTRC
36	1806362	Seal, MTRC, Oil
37	806419-185	Ring, Retaining-2 per
38	806192-078	Ring Ext RtnG, Waldes- 4 per
39	806610-0505016	Key, Mtrc, Rect, 5X5X16
40	806975-253	O Ring, 5.359 IDX.139W

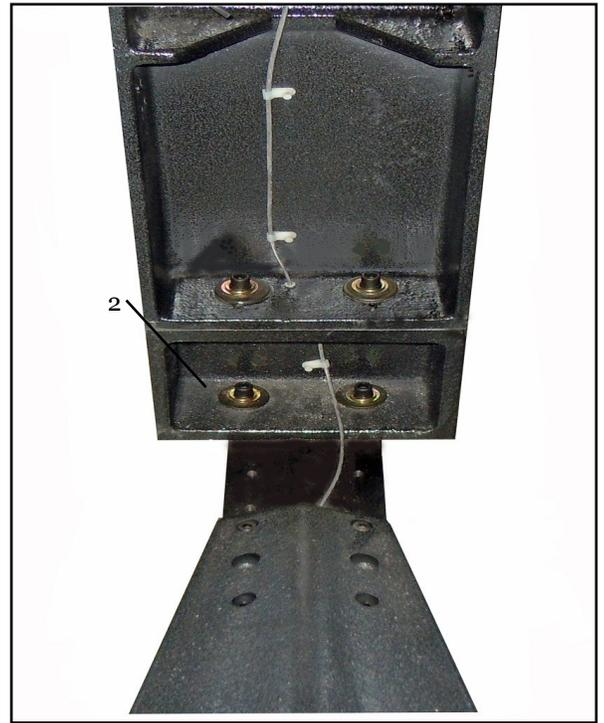
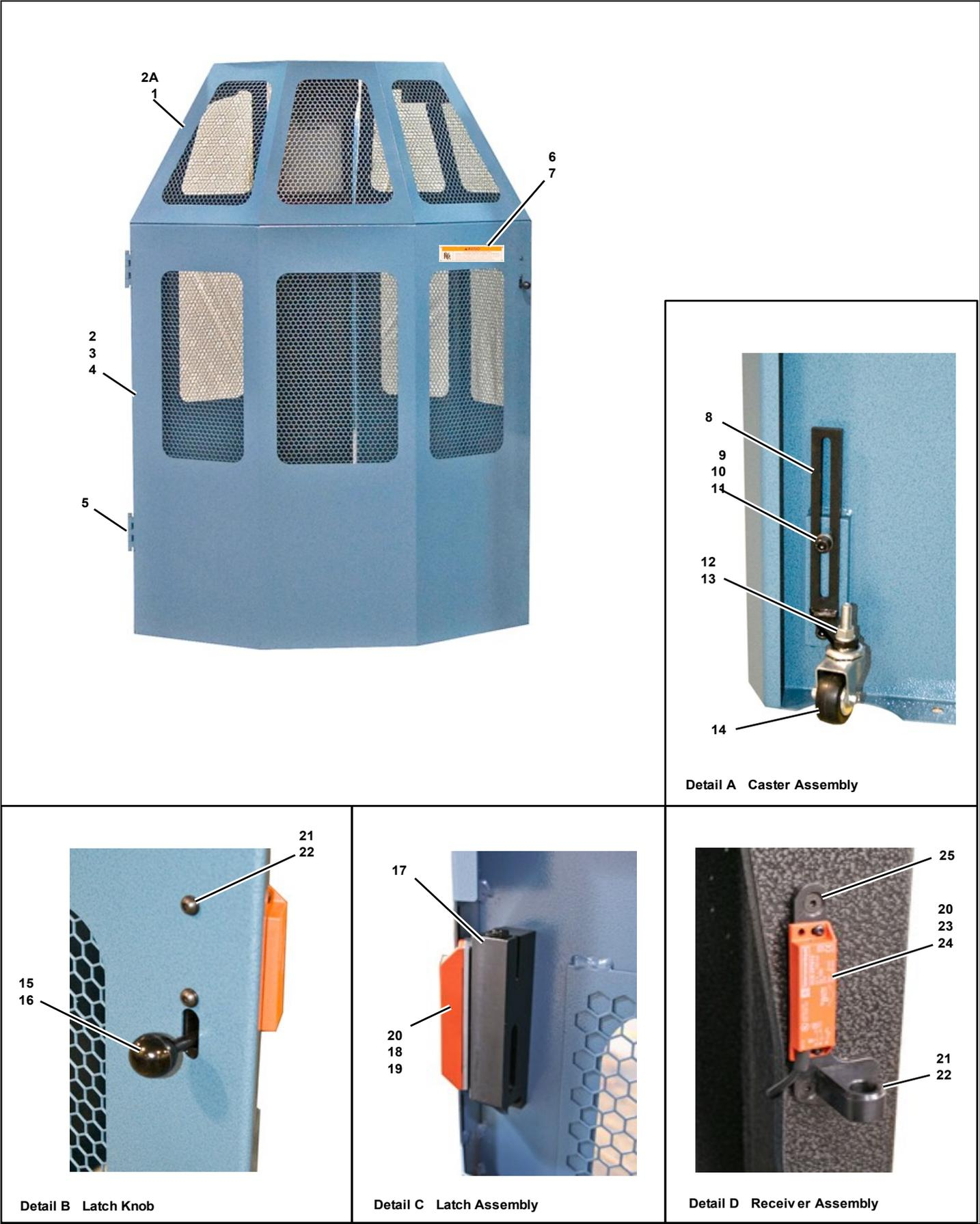
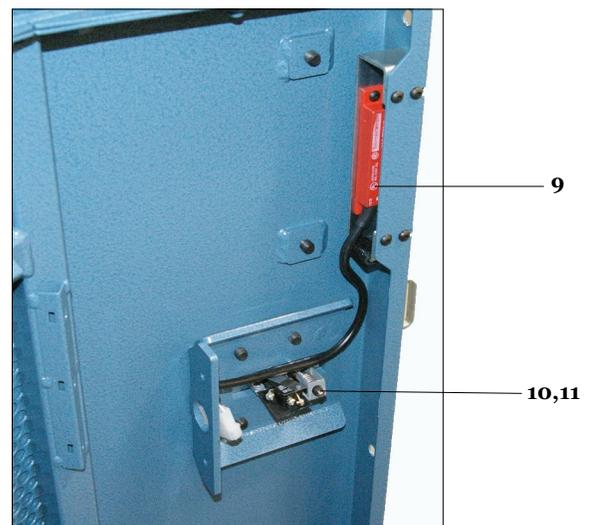
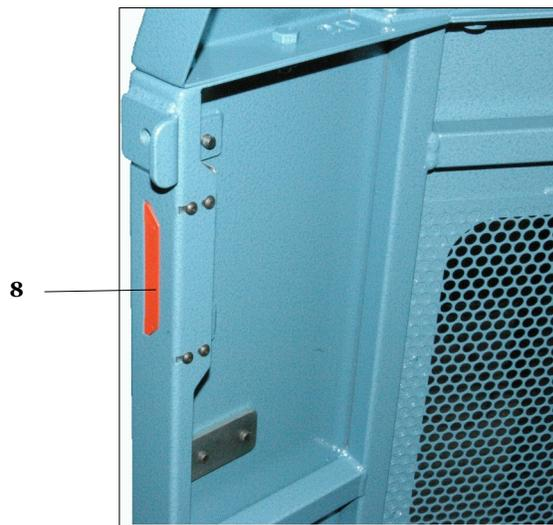
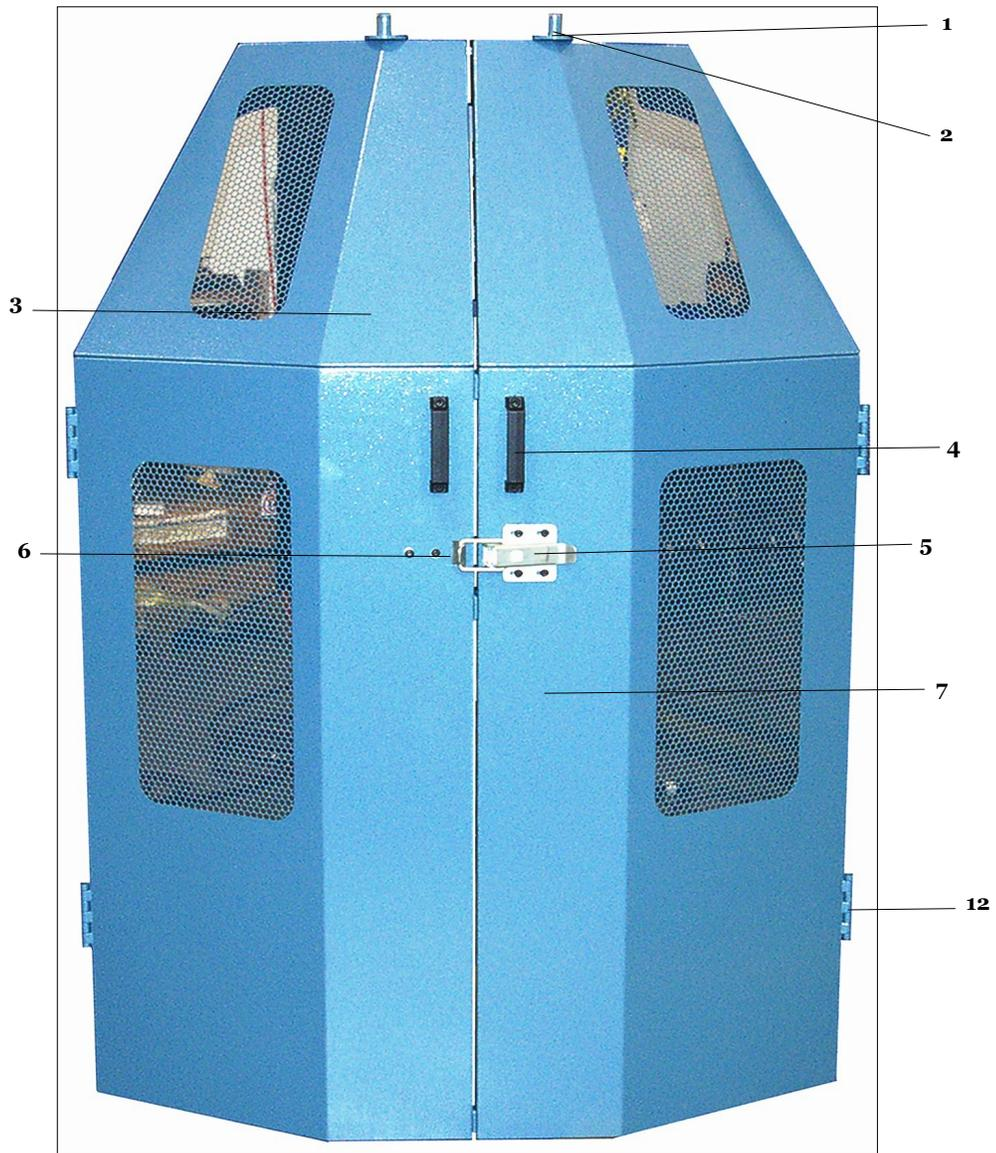

Figure 4A. SJ4AC/DI3 Frame Assembly

Item	Part Number	Description
1	106788-07	Plain Leg Extension (SJ4AC/DI3 machines only)
2	106788-107	Drive Leg Extension (SJ4AC/DI3 machines only)



Item	Part Number	Description
1A	119016-1GP 119016-GP 119016-2GP	Gate Assembly Jumbo Height Industrial Height Standard Height For Next Higher Assembly, See Figure 1.-2A
2A	118991-1GP 118991-GP 118991-2GP	Gate Jumbo Height Industrial Height Standard Height Includes Items 1 thru 5
1	106791-1GP 106791-GP 106791-2GP	Upper Gate Jumbo Height Industrial Height Standard Height
2	106812-1GP 106812-GP 106812-2GP	Lower Gate Jumbo Height Industrial Height Standard Height
3	806587-06012N	Socket Head Cap Screw, M6 x 1 x 12 mm Nyloc
4	806594-06	Hex Nut, M4 x 1
5	106482-01	Hinge
6	806178-501	Warning Label
7	806973-03	Blind Rivet
8	103691-13	Bracket
9	806584-08020	Socket Head Cap Screw, M8 x 1.25 x 20 mm
10	806606-06	Lock Washer, M8
11	806596-08	Flat Washer, M8
12	6157	Hex Nut, 3/8" x 16
13	6478	Lock Washer, M8
14	806713-01	Caster
15	118187-103	Gate Latch Assembly Includes Items 16 thru 19
16	806991	Plastic Knob
17	118187-101K	Latch Kit
18	806587-04010N	Button Head Cap Screw, M4 x .7 x 10 mm Nyloc
19	806598-04	Internal Tooth Lock Washer, M4
20	775565-01	Coded Magnet Switch (Supplied as a Set)
21	806197-103	Latch Receiver Assembly Includes Items 22 thru 24
22	118197-101K	Receiver Kit
23	806587-04010N	Button Head Cap Screw, M4 x .7 x 10 mm Nyloc
24	806598-04	Internal Tooth Lock Washer, M4
25	806586-06016	Countersink Socket Head Cap Screw, M6 x 1 x 16 mm



Split Gate Assembly (1A)

Item	Part Number	Description
1A	119016-1TABS 119016-101S7 119016-102S7	Gate Assembly Faceted (Jumbo Split) TABS= -105S, -100S, 101S, 102S, 103S. Gate Kit Split SJ4A/DI3 (16"-20") (Lincoln Co. Order 118991-101S7) Gate Kit Split SJ4A/DI3 (11"-16") (Lincoln Co. Order 118991-102S7)
1	1806374	Bracket, Stop
2	180375	Tubing, PVC
3	106791-1GPS	Gate Section ,Top
4	1806373	Handle, Plastic
5	1806370	Latch Buckle (Split Gates)
6	1806371	Latch Hook (Split Gates)
7	106812-1GPS	Gate Section ,Lower
8	1806372	Bracket/Magnetic Switch
9	775565-01	Coded Magnetic Switch (Supplied as Set)
10	805637	Switch, Stationary Gate
11	103999-22	Standoff, Switch
12	1806376	Shim,, Hinge (Split Gate) SJ4A/Delta

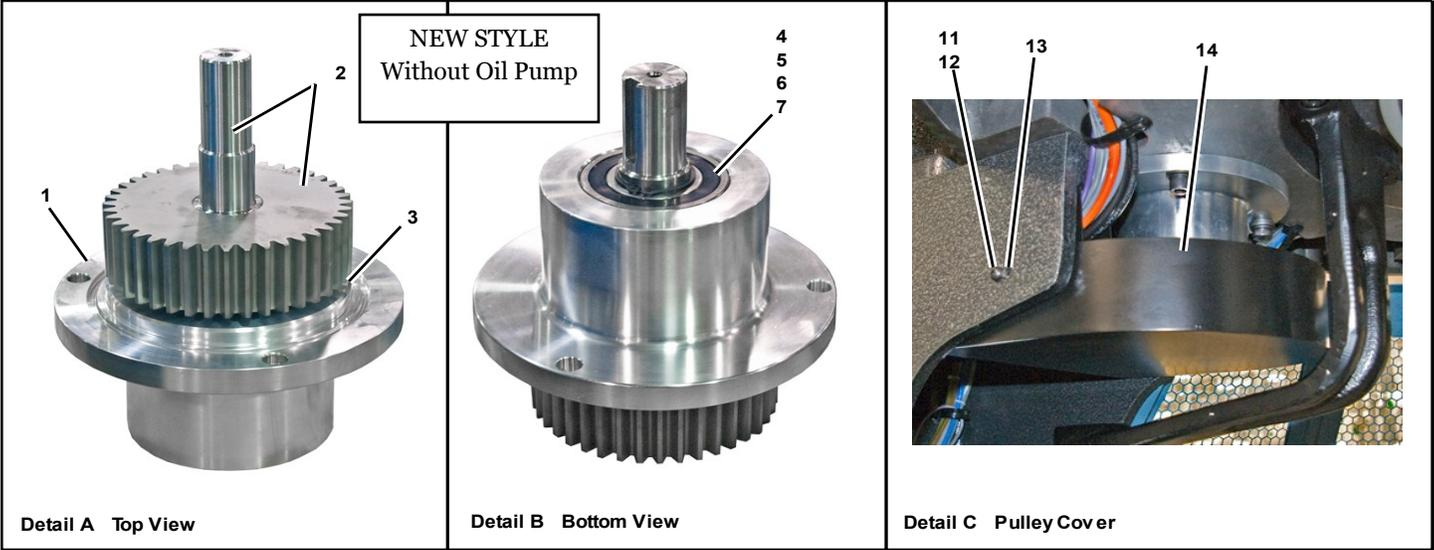
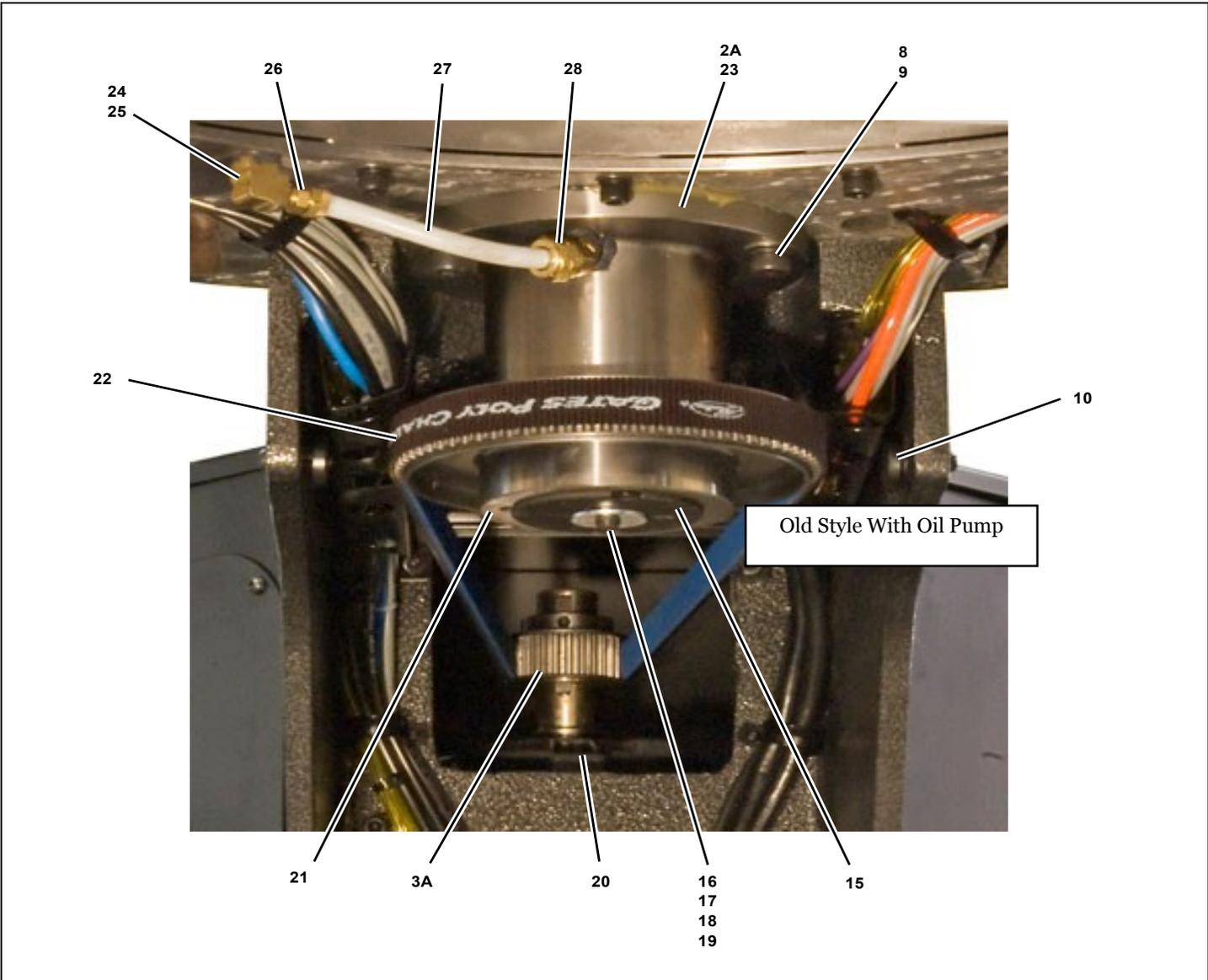
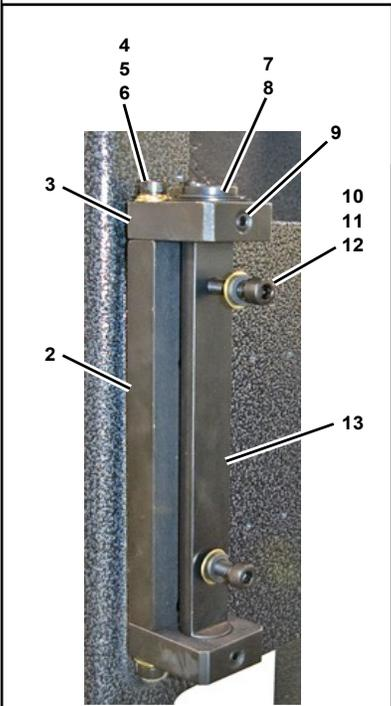
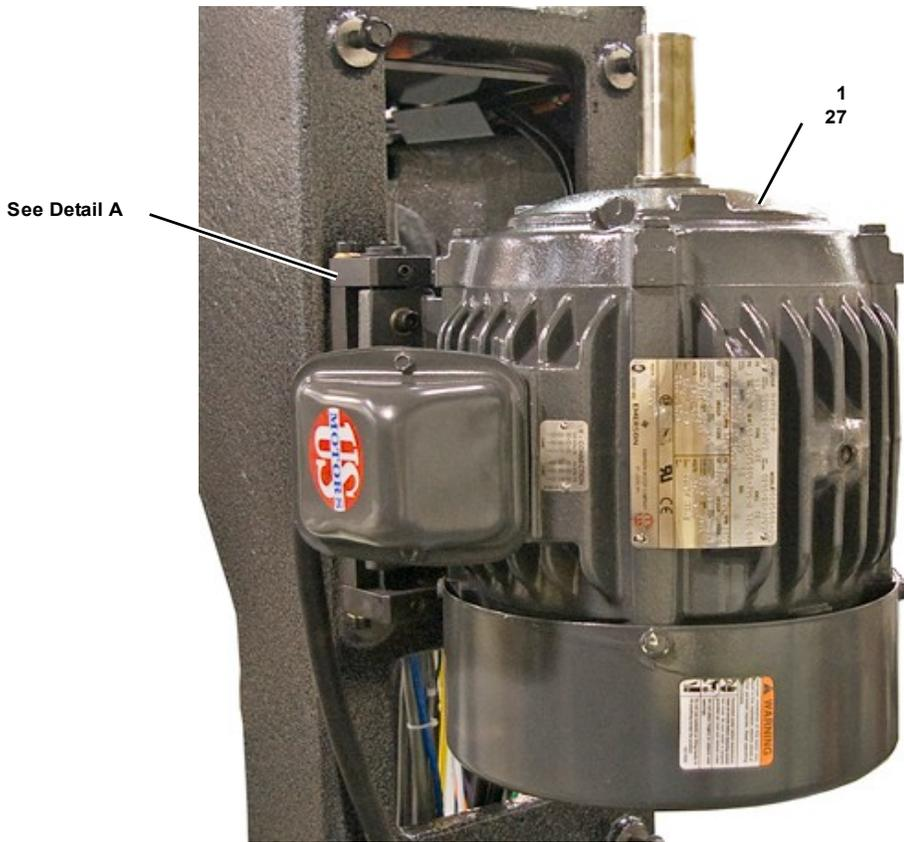
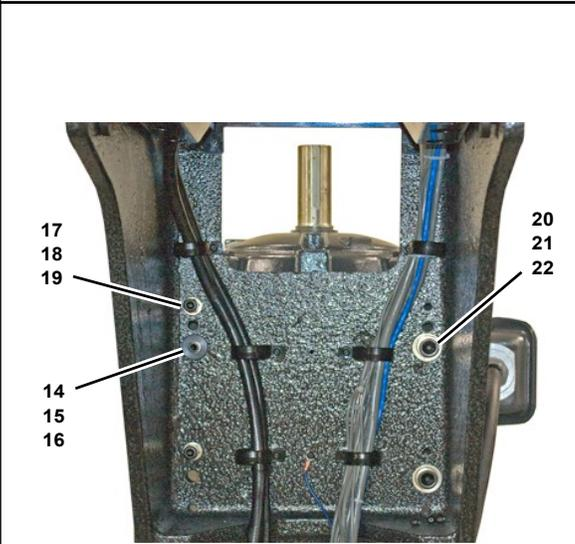

Figure 6. Drive Assembly with Oil Return (Old Style New Style Detail A,B and C)

Item	Part Number	Description
1A	119024-02	Drive Assembly with Oil Return For Next Higher Assembly, See Figure 4.-2A
2A	119023-02	Pinion Drive Assembly with Oil Return Includes Items 1 thru 7
3A		Motor Mounting Assembly
	119056	Used on Machines with 71 and 75 Tooth Driven Sprockets
	119057	Used on Machines with 90 Tooth Driven Sprocket See Figure 7. For Illustrated Parts Breakdown
1	106872-02	Housing with Oil Return
2	106873-01	Pinion Gear and Shaft Assembly
3	806581-09	Oil Seal (Under Pinion Gear)
4	806191-103	Bearing Clutch (Not Shown)
5	806419-283	Retaining Ring (Not Shown)
6	806192-137	Retaining Ring (Not Shown)
7	806191-103	Ball Bearing
8		Pinion Drive Housing Mounting Screws
	806584-10035	Socket Head Cap Screw, M10 x 1.5 x 35 mm (Shown)
	806601-10025	Socket Head Shoulder Screw, M10 x 1.5 x 25 mm (Pivot Point, Not Shown)
9		Pinion Drive Housing Mounting Washers
	806597-10	Lock Washer, M10 (Shown)
	806596-10	Flat Washer, M10 (Used on Item 8 Shoulder Screw, Not Shown)
	806596-12	Flat Washer, M12 (Used on Item 8 Shoulder Screw, Not Shown)
	806597-12	Lock Washer, M12 (Used on Item 8 Shoulder Screw, Not Shown)
10	106904	Clamping Disc
11	806587-06030	Button Head Cap Screw, M6 x 1 x 30 mm
12	806597-06	Lock Washer, M6
13	806441-11	Roll Pin, 0.125" x 0.75"
14	106903	Pulley Cover
15	1806188-30	Taper Lock Bushing
16	806584-06012	Socket Head Cap Screw, M6 x 1 x 12 mm
17	806597-06	Lock Washer, M12
18	7814	Flat Washer, 1/4" I.D. x 1" O.D. x 0.062 Thick
19	1806301	Fender Washer, .29" I.D. x 1.38" O.D. x 0.10 Thick
20		Drive Sprocket
	106924-25	25 Teeth
	106924-28	28 Teeth
21		Driven Sprocket
	1806191-71	71 Teeth
	1806191-75	75 Teeth
	1806191-90	90 Teeth
22		Drive Belt
	806920-1600	Used on Machines with 71 and 75 Tooth Driven Sprockets
	806920-1750	Used on Machines with 90 Tooth Driven Sprocket
23	806975-253	O-Ring, 5.359" I.D. x 0.139 Diameter
24	808362-1825	Elbow, 90 Degree x 1/8 NPT
25	1806321	Nipple, 1/8 NPT x 3/8" Tube
26	808362-1813	Fitting, 1/8 NPT x 3/8" Tube
27	007395	Tubing, 3/8" O.D. Translucent
28	808362-1879	Fitting, 45 Degree x 1/8 NPT x 3/8" Tube



Detail A Motor Hinge



Detail B Hinge Mounting and Adjusting Hardware

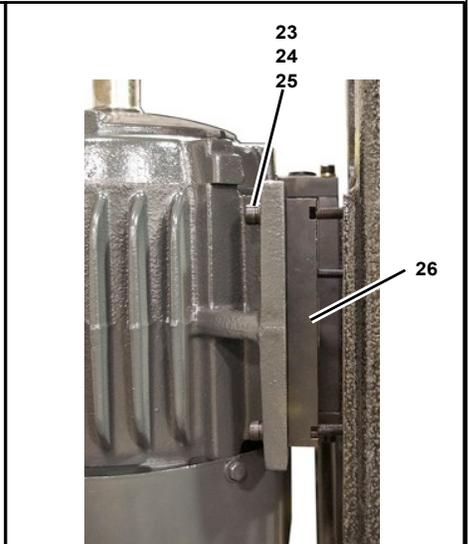

Detail C Motor Pressure Bar

Figure 7. Motor Mounting Assembly

Item	Part Number	Description
1A	119056 119057	Motor Mounting Assembly Used on Machines with 71 and 75 Tooth Driven Sprockets Used on Machines with 90 Tooth Driven Sprocket For Next Higher Assembly, See Figure 6.-3A
1	530052-754A 530052-754C	Motor 230/380/460 Volt, 50/60Hz 575 Volt, 50/60Hz
2	106963	Hinge Base Bracket
3	106961-01 106961-02	Hinge Holding Bracket Used on Machines with 71 and 75 Tooth Driven Sprockets Used on Machines with 90 Tooth Driven Sprocket
4	806584-08035	Socket Head Cap Screw, M8 x 1.25 x 35 mm
5	806597-08	Lock Washer, M8
6	806596-08	Flat Washer, M8
7	806476	Retaining Ring
8	1806282	Flat Washer, 1" I.D. x 1 1/2" O.D. x 0.48" Thick
9	806590-0808FP	Socket Head Set Screw, M8 x 1.25 x 8 mm Flat Point
10	806584-08030	Socket Head Cap Screw, M8 x 1.25 x 30 mm
11	806597-08	Lock Washer, M8
12	806596-08	Flat Washer, M8
13	106964	Hinge Shaft
14	806584-06055	Socket Head Cap Screw, M6 x 1 x 55 mm
15	806597-06	Lock Washer, M6
16	1806194-03Z	Flat Washer, 0.265" I.D. x 1" I.D. x 1/8" Thick
17	806584-08060F	Socket Head Cap Screw, M8 x 1.25 x 60 mm Full Thread
18	806597-08	Lock Washer, M8
19	806594-08	Hex Nut, M8
20	806584-12045	Socket Head Cap Screw, M12 x 1.75 x 45 mm
21	806597-12	Lock Washer, M12
22	806596-12	Flat Washer, M12
23	806584-08025	Socket Head Cap Screw, M8 x 1.25 x 25 mm
24	806597-08	Lock Washer, M8
25	806596-08	Flat Washer, M8
26	106962-01 106962-02	Hinge Pressure Bar Used on Machines with 71 and 75 Tooth Driven Sprockets Used on Machines with 90 Tooth Driven Sprocket
27	806178-508	Motor Rotation Label (Not Shown)

This page intentionally left blank

SECTION 2. ELECTRICAL ASSEMBLY

	<u>Page</u>
Figure 8. Electrical Assembly.....	<u>34</u>
Figure 9. Chassis Assembly	<u>36</u>
Figure 10. Control Panel and Sensors	<u>40</u>

NOTICE

SJ4AC/D, DI, DI2,SJ3AC/D and DL

Group Number Represents Machine Diameter:

31" thru 36"	Group 5
26" thru 30"	Group 0
21" thru 25"	Group 1
16" thru 20"	Group 2
11" thru 15"	Group 3

SJ4AC/DI3

16" thru 20"	Group 1
11" thru 15"	Group 2



Figure 8. Electrical Assembly

Item	Part Number	Description
1A	119040-VOLTAGE	Power Supply Assembly
2A	No P/N	Chassis Assembly See Figure 9. for Parts Breakdown
1	101130-55	Enclosure
2		Logo Plate
	806178-57B	Aluminum with Multi-Color Finish and Adhesive Back
	806178-57A	Diecast with Chrome and Black Finish
3	806990-01	Push Nut (Used on Diecast Logo Plate, P/N 806178-57A Only)
4	806178-5Voltage	Warning Plate - Electric Shock
5	806973-03	Rivet
6	775545-03	Fan Guard
7	806178-506	Notice Plate - Clean Fan Filter
8	806973-03	Rivet
9	806178-507	Notice Label - Type 1 Enclosure
10	806178-504	Warning Label - Electric Shock
11	No Part Number	Fusing Chart
12	806967-05	Lock and Key Assembly
13	806178-505	Main Power Plate
14	806973-03	Rivet
15	775538-03	Power Switch
16	806178-503	Warning Plate - Read Operator's Manual
17	806973-03	Rivet
18	806178-517	Plate - Electrical Serial Number
19	806973-03	Rivet
20	775545-02	Fan Filter
21	805200-01	Neoprene Foam Seal (Not Shown)

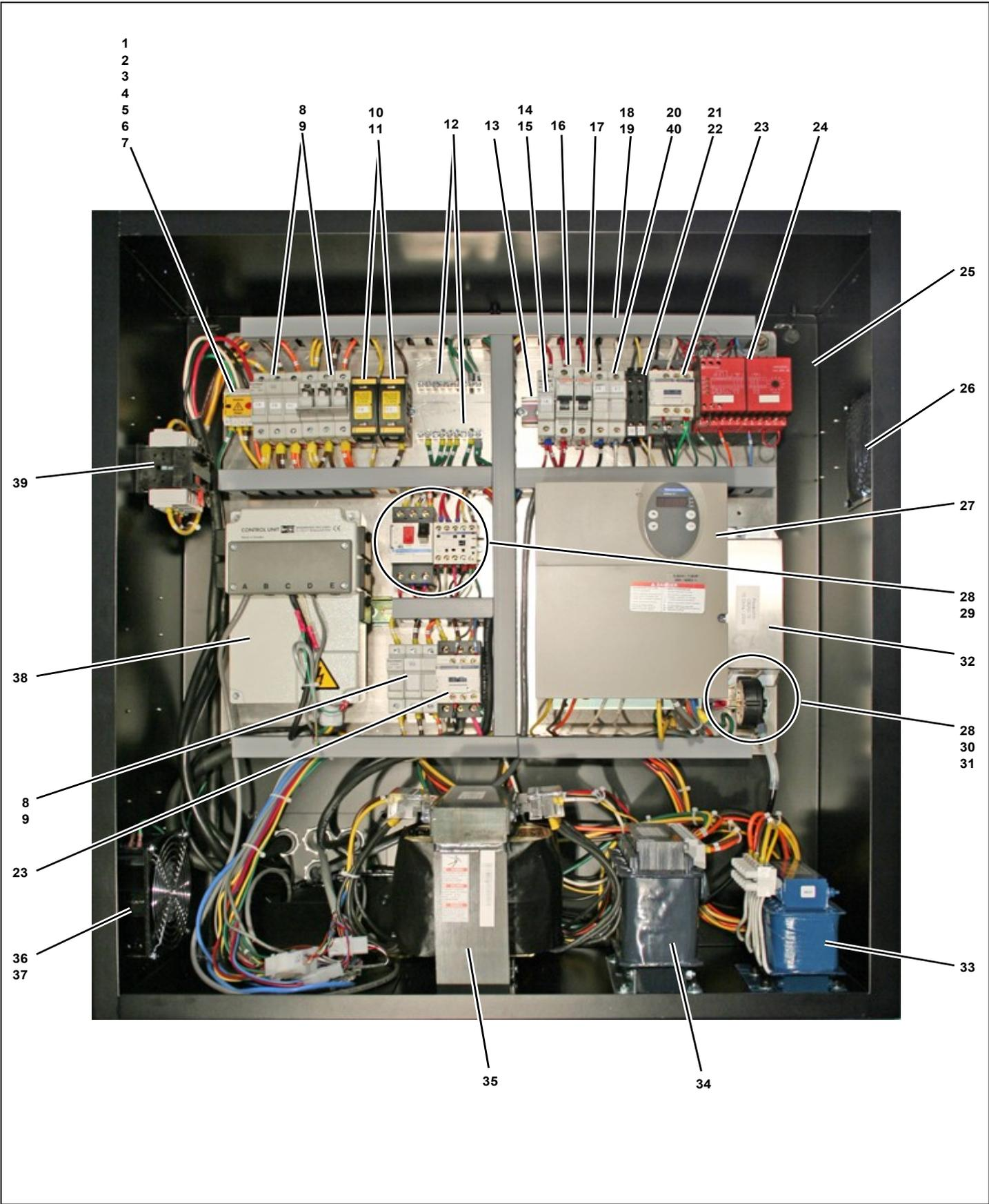

Figure 9. Chassis Assembly with MRA
 (Page 1 of 2)

Item	Part Number	Description
1A		Chassis Assembly For Next Higher Assembly, See Figure 8.-2A
1	775436-60	Terminal Block, Power
2	775436-61	Terminal Block, Ground
3	775436-62	Label, 1
4	775436-63	Label, 2
5	775436-64	Label, 3
6	775436-65	Label, PE
7	775436-66	Label, Danger
8	775535-12	3 Pole Fuse Block
9		Fuse
	775536-08	8 Amp, Class CC, 230 Volt Machine
	775536-15	15 Amp, Class CC, 230 Volt Machines
	775536-20	20 Amp, Class CC, 380/460 Volt Machines
	775536-30	30 Amp, Class CC, 575 Volt Machines
10	775578	Fuse Block Cover
11		Fuse
	775578-045	4.5 Amp, Class J, 230 Volt Machines
	775578-08	8 Amp, Class J, 575 Volt Machines
	775578-10	10 Amp, Class J, 380/460 Volt Machines
12	775436-26	Grounding Bar
13	775464-Z	Component Mounting Rail
14	775535-10	1 Pole Fuse Block
15	775033-14	Fuse, 12 Amp Time-Delay 600Volt
16	775458-27	Circuit Breaker, 6 Amp
17	775458-26	Circuit Breaker, 2 Amp
18	775437-38	Wire Duct, 1" x 2"
19	775437-14	Wire Duct Cover
20	775535-11	2 Pole Fuse Block
21	775436-67	Fuse Holder
22	775033-5	Fuse, 2 Amp
23	775460-09	Contactator, 3 Phase
24	775581-01	Safety Gate Switch Module
25	103305-25	Chassis
26	775545-02	Fan Filter
27		Inverter
	775592-0255	230 Volt Machines
	775592-0455	380/460 Volt Machines
	775592-0655	575 Volt Machines
28		Filter Flow Rail Kit
	118874-01	230 Volt Machines
	118874-02	380/460 Volt Machines
	118874-03	575 Volt Machines
		(Includes Items 29 thru 31)
29		Filter Flow Component Rail
	117722-4301	230 Volt Machines
	117722-4302	380/460 Volt Machines
	117722-4303	575 Volt Machines
30	20-9703	Vacuum Switch with Bracket
31	806587-04010	Button Head Cap Screw, M4 x .7 x 10 mm

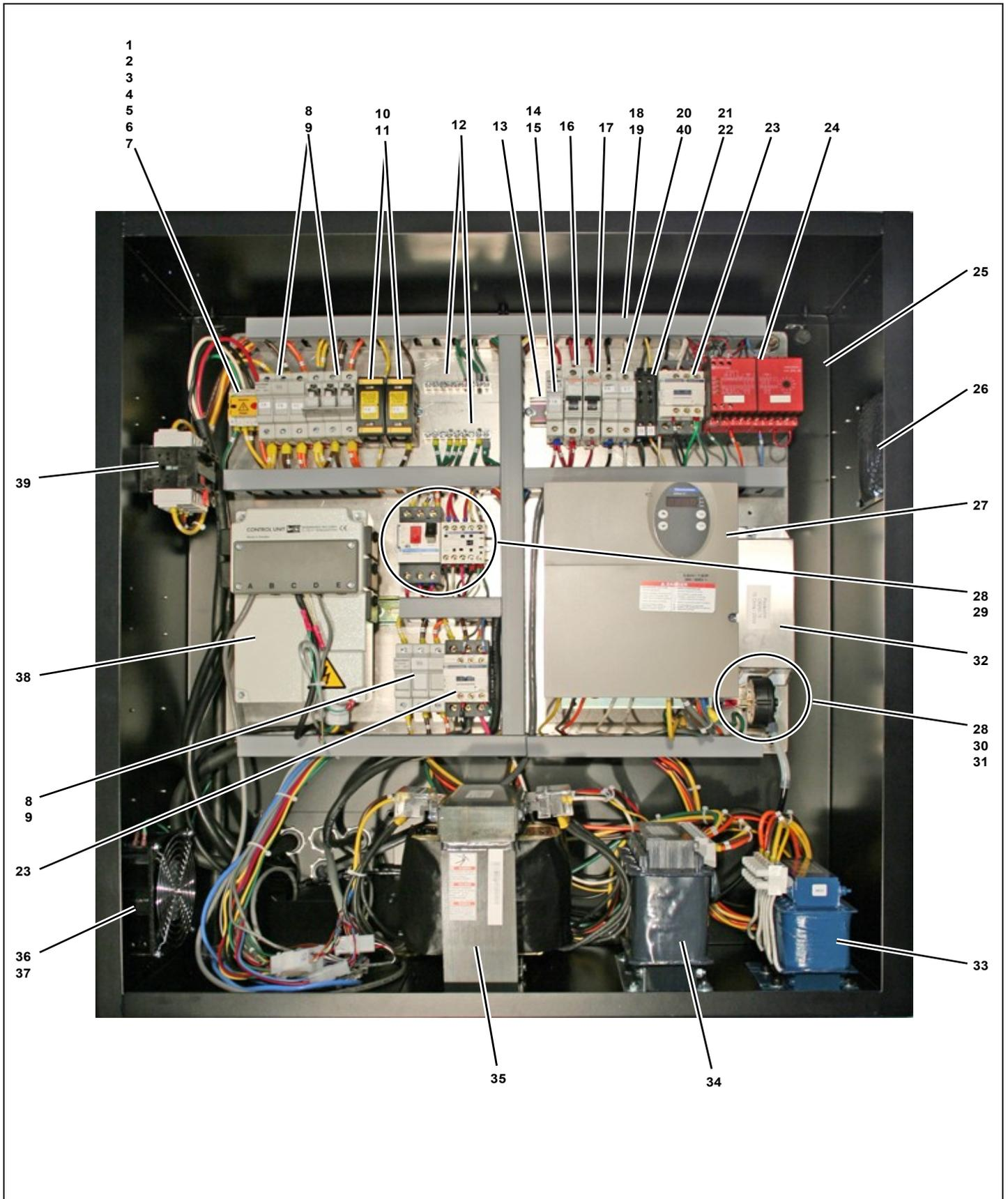

Figure 9. Chassis Assembly

(Page 2 of 2)

Item	Part Number	Description
32	775592-255 775592-455 775592-655	Brake Resistor 230 Volt Machines 380/460 Volt Machines 575 Volt Machines
33	775530	Reactor
34	777102	Transformer, IRO Motorized Feeder Drive System
35	775380-23 775380-24	Transformer 1950 VA, 380/460 and 575 Volt machines 450 VA, 230 Volt Machines
36	775545-04	Box Fan, 110 CFM, 120 Volt
37	775545-03	Wire Fan Guard
38	777101	Controller, IRO Motorized Feeder Drive System
39	775538-03	Power Switch
40	775536-10	Fuse, 10 Amp, Class CC

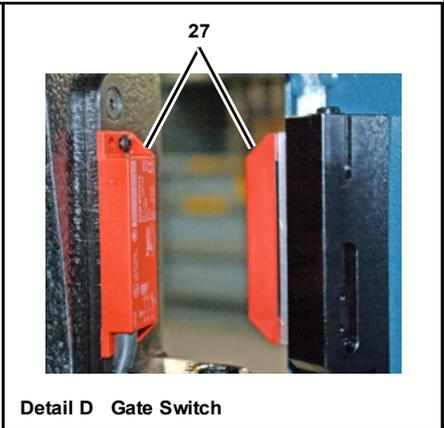
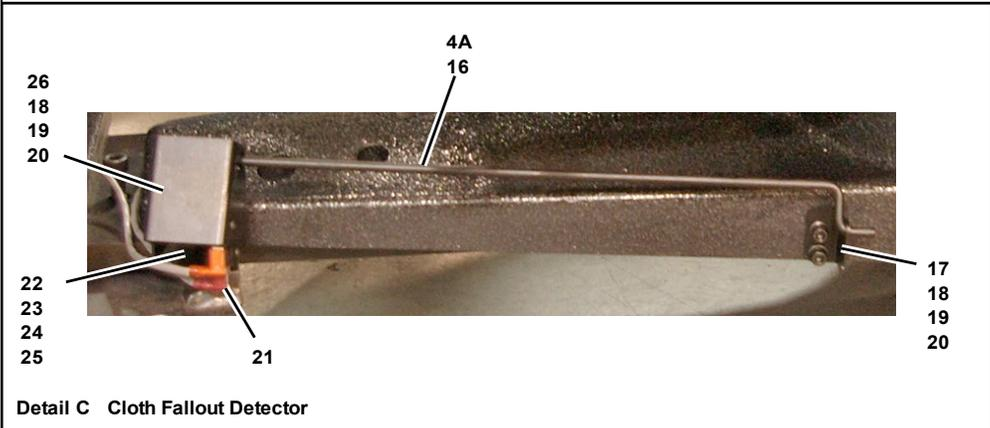
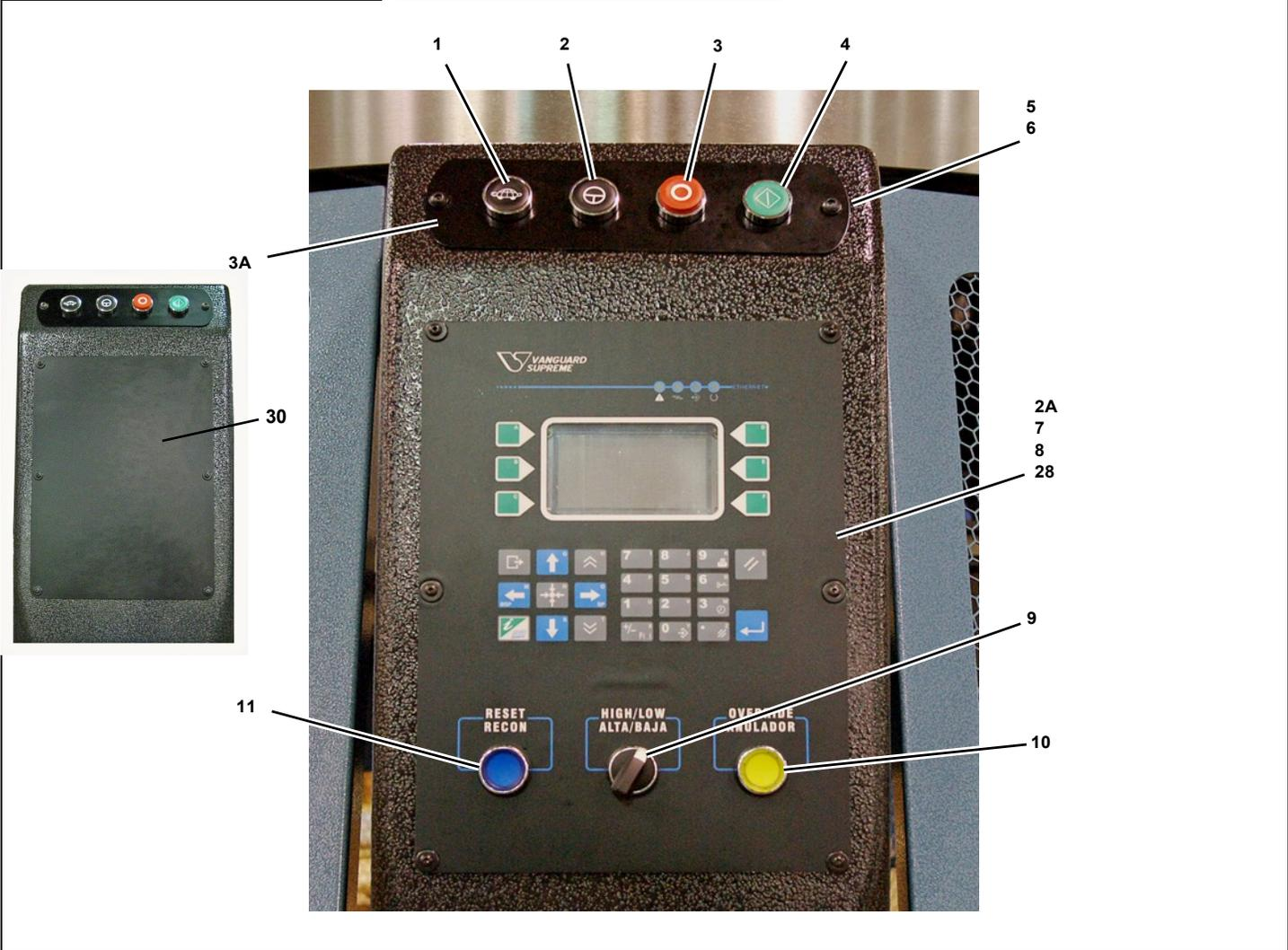
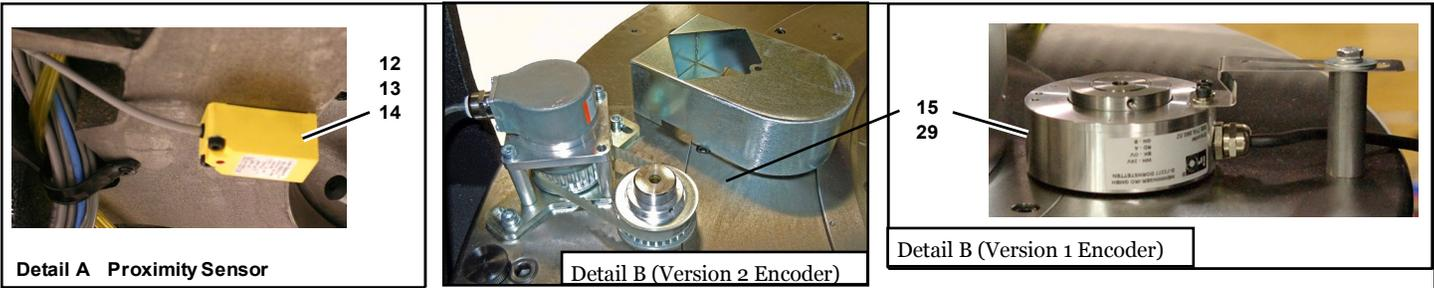

Figure 10. Control Panel and Sensors

Item	Part Number	Description
1A	No P/N	Control Panel and Sensors
2A	119028-02	Operator Panel Assembly Includes Items 9, 10, 11
3A	119041	Pushbutton Assembly Includes Items 1 thru 6
4A	119071	Cloth Fallout Switch Includes Items 16 thru 26
1	777002-12	Inch Pushbutton (Black)
	777002-12-C	Cap for Black Inch Pushbutton
2	777002-03	Jog Pushbutton (Black)
	777002-03-C	Cap for Black Jog Button
3	777002-01	Stop Pushbutton (Red)
	777002-01-C	Cap for Red Stop Pushbutton
4	777002-02	Start Pushbutton (Green)
	777002-02-C	Cap for Green Start Pushbutton
5	106900	Plate
6	806587-06012	Button Head Cap Screw, M6 x 1 x 12 mm
7	806587-04018	Button Head Cap Screw, M4 x .7 x 18 mm
8	806596-04	Flat Washer, M4
9	775441-24	High/Low Speed Switch (Used on Earlier Models Only)
10	775441-28	Override Pushbutton (Used on Earlier Models Only)
	777002-14--C	Cap for Orange Override Pushbutton
11	775441-22	Reset Pushbutton (Used on Earlier Models Only)
	777002-13-C	Cap for Blue Reset Pushbutton
12	775515	Proximity Switch
13	806584-04025	Socket Head Cap Screw, M4 x .7 x 25 mm
14	806598-04	Internal Tooth Lock Washer, M4
15	777100	IRO Memminger Encoder (Version 1, Right) (Version 2, Left)
16	106658-01	Activating Rod
17	106998	Support Bracket
18	806594-06012	Socket Head Cap Screw, M6 x 1 x 12 mm
19	806597-06	Lock Washer, M6
20	806596-06	Flat Washer, M6
21	775446-24	Connector
22	775516	Microswitch
23	806587-03016	Button Head Cap Screw, M3 x .5 x 16 mm
24	806597-03	Lock Washer, M3
25	806594-03	Hex Nut, M3 x .5
26	106997	Cover
27	775565-01	Coded Magnetic Switch (Supplied as a Set)
28	106993	Operator Panel Back Cover (Not Shown)
29	104891-01	Felt Dust Seal
30	106928	Plain Leg, Cover Plate



1A- Display Panel Assembly, Host System Kit

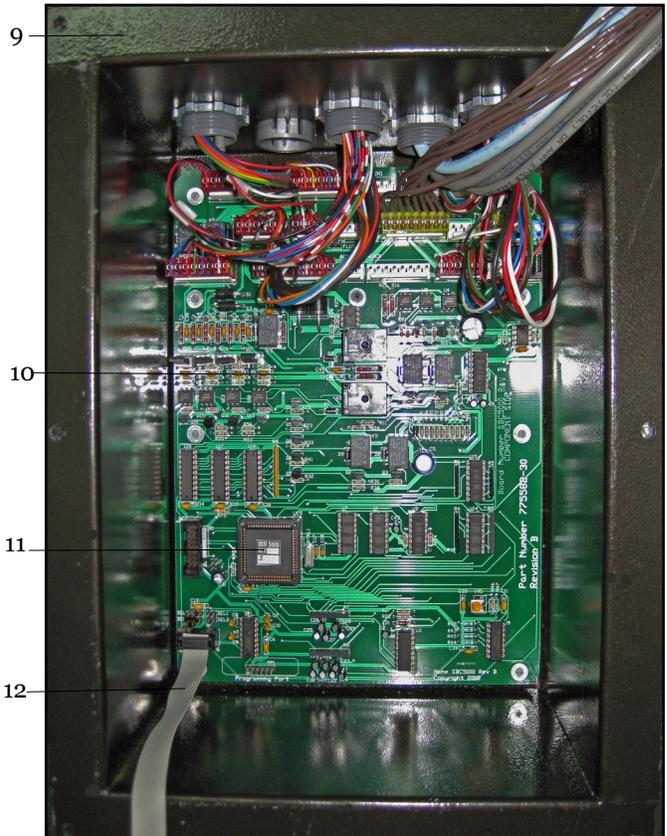
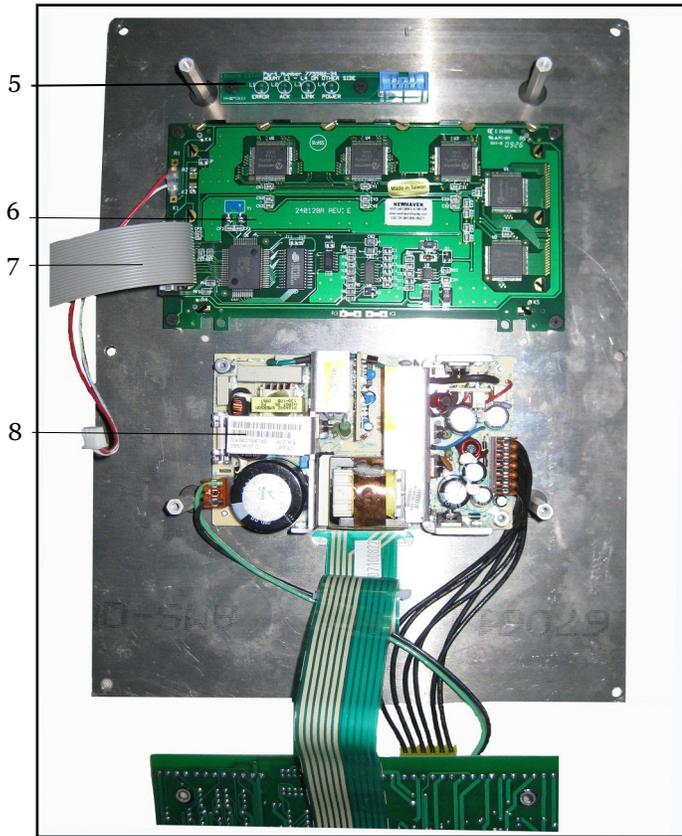
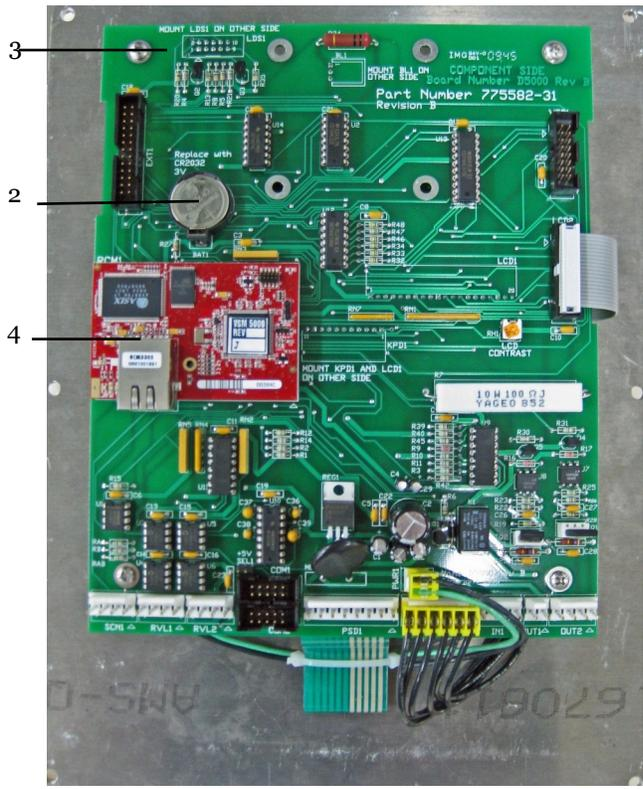

Figure 10.5 (1A) 5000 Series Control Panel

Item	Part Number	Description
1A	119028-03	Display Panel Assembly ,Host System Kit
1	119074-02	Overlay, Plate Assy. VPL5000
2	775621-01	Battery, CR2032
3	775582-31	PC Board
4	775612-04	PCB Microcomputer VPL5000
5	775582-34	PCB, LED CKT
6	775614-01	PCB, LCD, Displ, Grph
7	775583-06	Cable Rbn, 20 Conductor DSPL
8	775480-12	Power Supply, Dual 5-12 Volts
9	108199	Cover
10	775582-30	PCB, CONT CKT VPL5000
11	775612-02	IC, I/O, Mem.
12	775583-05	Cable , Ribbon, I/O Conduct Com.

This page intentionally left blank

SECTION 3. OIL AND AIR DISTRIBUTION ASSEMBLY

	<u>Page</u>
Figure 11. Oil and Air Distribution Assembly	<u>46</u>

NOTICE

SJ4A/D, DI, DI2, SJ3A/D and DL

Group Number Represents Machine Diameter:

31" thru 36"	Group 5
26" thru 30"	Group 0
21" thru 25"	Group 1
16" thru 20"	Group 2
11" thru 15"	Group 3

SJ4A/DI3

16" thru 20"	Group 1
11" thru 15"	Group 2

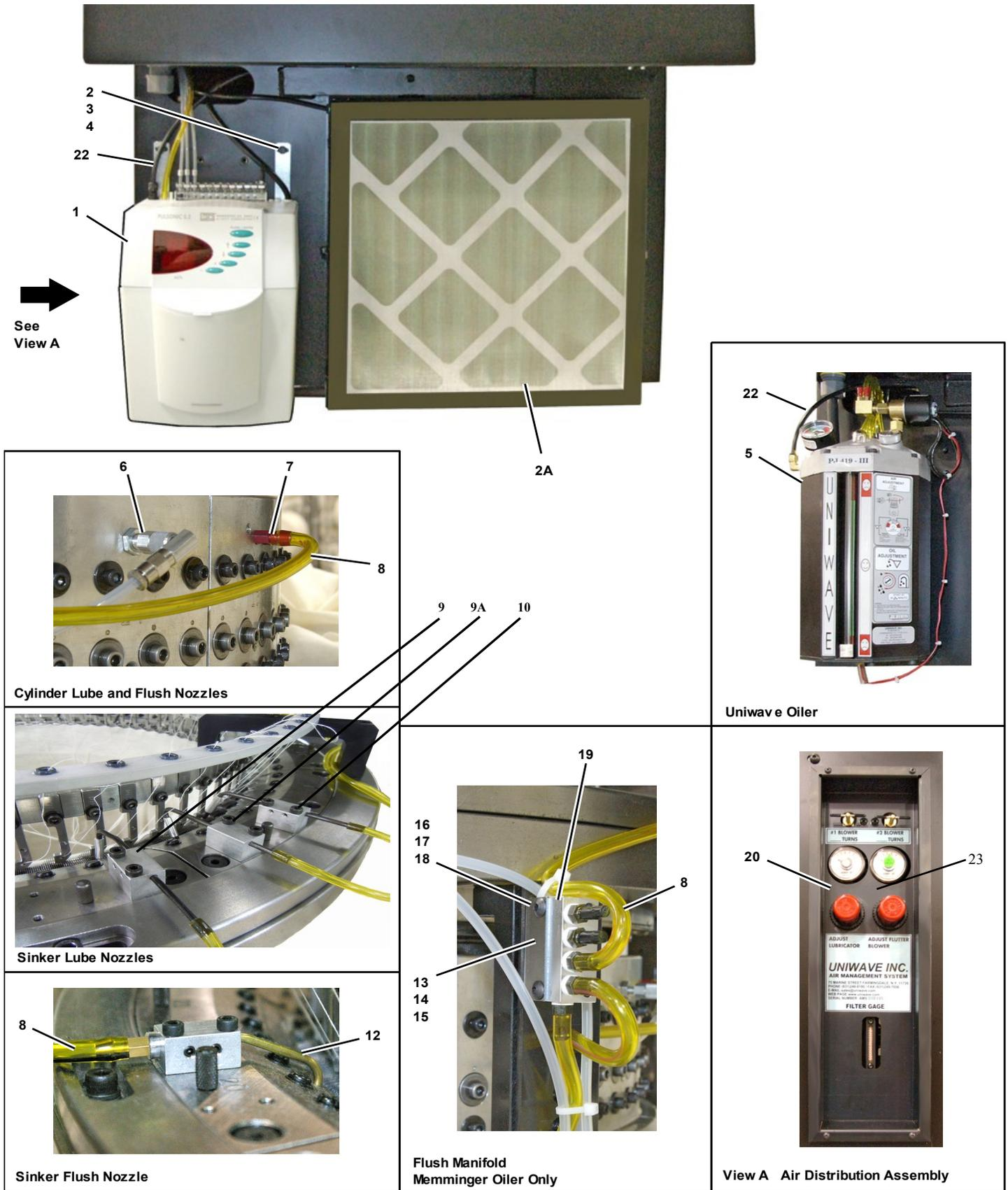

Figure 1. Oil and Air Distribution Assembly

Item	Part Number	Description
1A	119026-10 119026-20	Oil and Air Distribution Assembly Uniwave Oiler Memminger Oiler
2A	No P/N	Filter Flow Assembly (Air Chamber Not Shown) See Section 5. For Illustrated Parts Breakdown
1	808362-2715	Memminger Oiler
2	806584-06016	Socket Head Cap Screw, M6 x 1 x 16 mm
3	806597-06	Lock Washer, M6
4	806596-06	Flat Washer, M6
5	808362-3001	Uniwave Oiler
6		Cylinder Lubrication Nozzle
	808447-22	Uniwave, 22 mm
	808449-30	Memminger, 30 mm with Lock Nut
7		Cylinder Flush Nozzle
	808448-02	Uniwave, M4 Barb
	808448-12	Memminger, 1/4" Barb
8		Flush Tubing
	808419	Uniwave, 4 mm ID (Yellow with Black Stripe)
	007394-01	Memminger, 1/8" ID (Yellow with Red Stripe)
9		90° Angled Sinker Lubrication Nozzle
	808450-01	Uniwave
	808450-11	Memminger
		(Sinker lubrication nozzles include mounting screw, part number 806584-04025, M4 x .7 x 25 mm)
9A		<u>Nozzle Oil Mist 20/90Deg Sn (USED ON MACHINES WITH TRIPLE PUSH SINKER CAMS)</u>
	808450-03	Uniwave
	808450-13	Memminger
		(Sinker lubrication nozzles include mounting screw, part number 806584-04025, M4 x .7 x 25 mm)
10		45° Angled Sinker Lubrication Nozzle
	808450-12	Uniwave
	808450-12	Memminger
		(Sinker lubrication nozzles include mounting screw, part number 806584-04025, M4 x .7 x 25 mm)
11		Lubrication Tubing
	007394-02	Uniwave (Yellow)
	808374-38	Memminger (White)
12		90° Angled Sinker Flush Nozzle
	808451-01	Uniwave
	808451-11	Memminger
		(Sinker lubrication nozzles include mounting screw, part number 806584-04025, M4x7x25 mm)
13	104429	Manifold Mounting Bracket
14	806584-04010	Socket Head Cap Screw, M4 x .7 x 10 mm
15	806598-04	Internal Tooth Lock Washer, M4
16	806587-04025	Button Head Cap Screw, M4 x .7 x 25 mm
17	806598-04	Internal Tooth Lock Washer, M4
18	806594-04	Hew Nut, M4 x .7
19	808421	Flush Manifold and Plug Cap
20	808362-2506	Air Preparation Assembly
21	808452	Connector Pipe (Not Shown) Uniwave oiler only, used to allow flush tubing to pass through sinker ring support bracket)
22	808374-33	Tubing, 1/4" O.D. Black
23	108177	Plexiglas Cover (Not Shown)

This page intentionally left blank

SECTION 4. TAKEUP ASSEMBLY

	<u>Page</u>
Figure 12. Take-up and Cloth Splitter Assembly.....	<u>50</u>
Figure 13. Table Assembly.....	<u>52</u>
Figure 14. Take-up Drive Assembly and Rollers	<u>58</u>
Figure 15. Drive Sidewall Assembly (New Style)	<u>62</u>
Figure 16. Drive Sidewall Assembly (Old Style)	<u>66</u>
Figure 17. Driven Sidewall Assembly.....	<u>70</u>
Figure 18. Swing Arm Assembly with Tapered Elevating Roller.....	<u>72</u>
Figure 19. Swing Arm Assembly with Rack and Pinion Elevating Roller.....	<u>74</u>
Figure 20. Roll Containing Guide Assembly	<u>76</u>
Figure 21. Worm Gear Assembly	<u>80</u>
Figure 22. Version 2 , Worm Gear Assembly.....	<u>82</u>

NOTICE

SJ4AC/D, DI, DI2,SJ3AC/D and DL

Group Number Represents Machine Diameter:

31" thru 36"	Group 5
26" thru 30"	Group 0
21" thru 25"	Group 1
16" thru 20"	Group 2
11" thru 15"	Group 3

SJ4AC/DI3

16" thru 20"	Group 1
11" thru 15"	Group 2

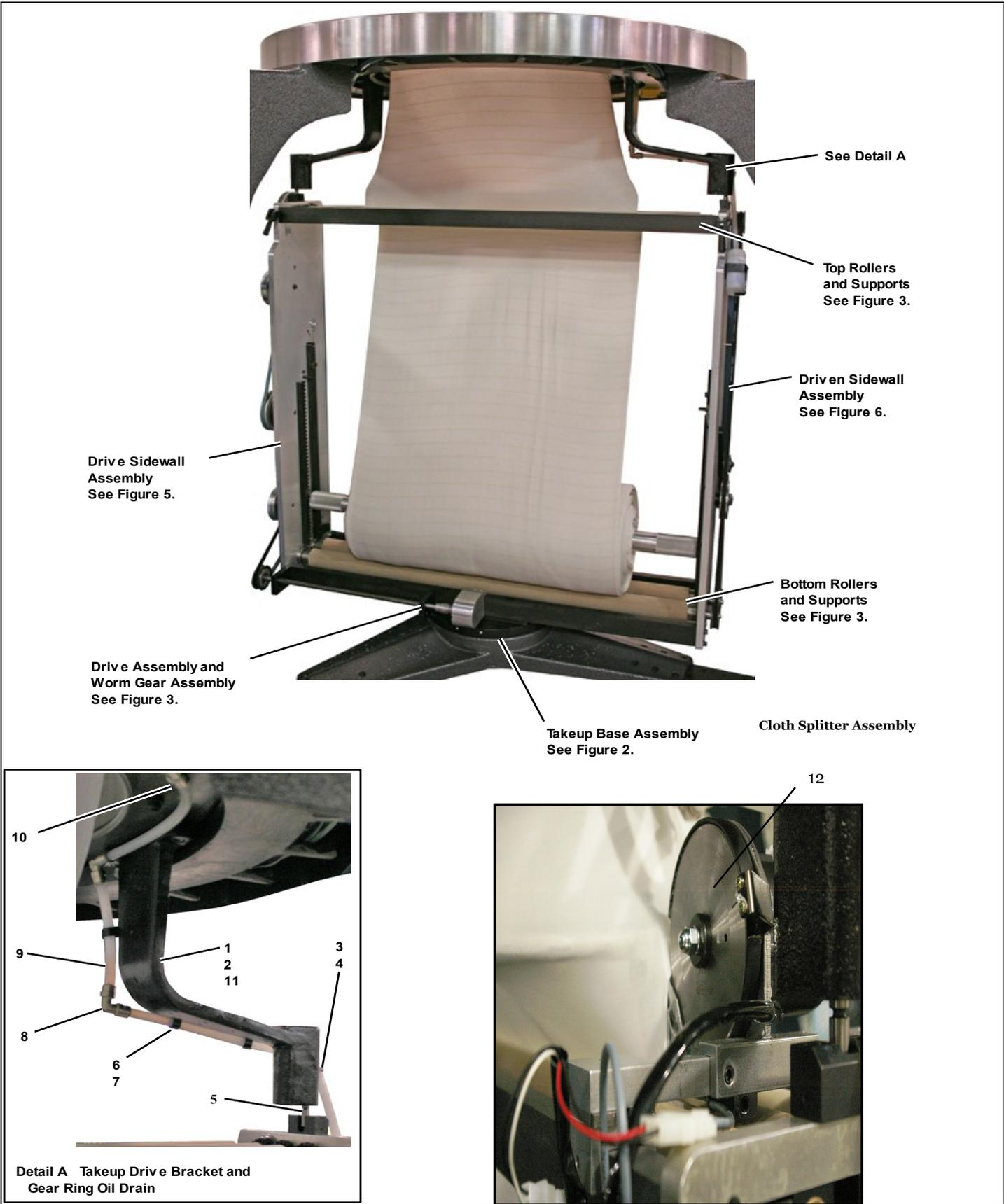
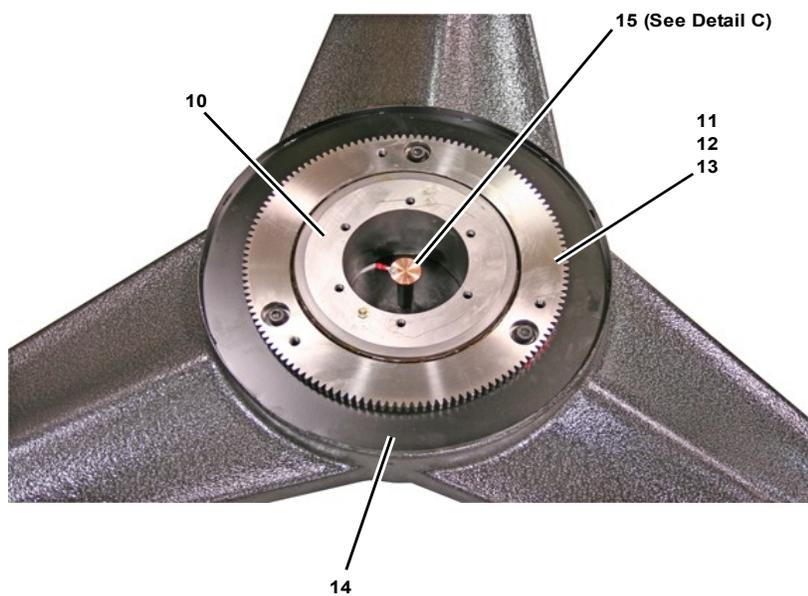
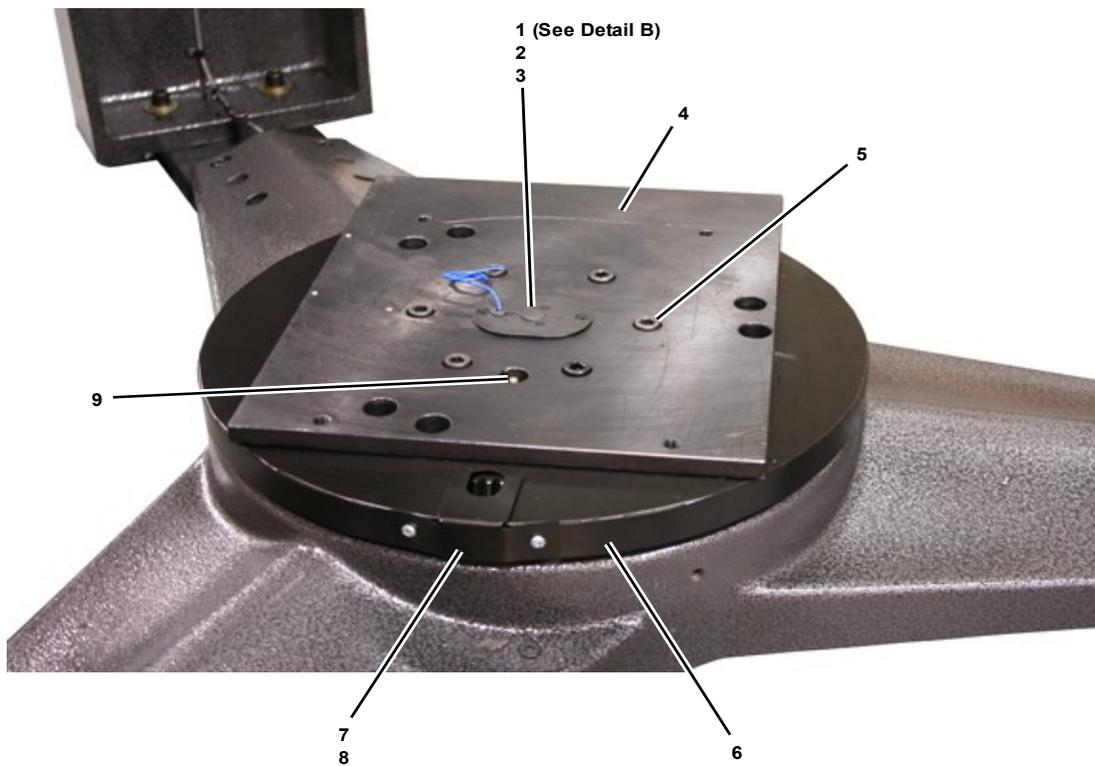
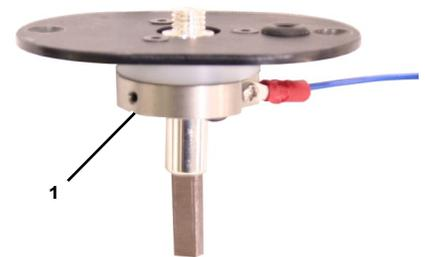

Figure 12. Take up and Cloth Splitter Assembly

Item	Part Number	Description
1A	119025-TAB 119075-TAB	Take-up Assembly With Rack and Pinion Elevating Roller With Tapered Elevating Roller (-TAB = Group Size and Take-up Height)
1	106930-01 106930-02	Drive Bracket All Models Except Machines with 48" Take-up Groups 2 and 3 with 48" Take-up
2	806584-10030	Socket Head Cap Screw, M10 x 1.5 x 30 mm
3	806585-10035	Hex Head Cap Screw, M10 x 1.5 x 35 mm
4	806594-10	Hex Nut, M10 x 1.5
5	104352-01	Drive Pin
6	775116-12	Cable Clamp, 3/4"
7	806584-04008	Socket Head Cap Screw, M4 x .7 x 8 mm
8	808362-1876	Elbow, 1/2" Diameter Tube
9	808446-0500	Tubing, 1/2" Diameter
10	808362-1874	Threaded Tee, 3/8-18 NPT x 1/2" Diameter Tube
	808362-1875	Threaded Elbow, 3/8-18 NPT x 1/2" Diameter Tube
	808362-1877	Adapter, 3/8 FPT x 3/8 MPT (New Style Only)
	808362-1878	Tee, Non-Threaded, 1/2" Diameter Tube (New Style Only)
	806596-16	Flat Washer, M16 (Used as Spacer, New Style Only)
11	806178-510	Take-up Rotation Label (Not Shown) 2 Labels, English and Spanish
12	PL-8000-Z28	Cloth Splitter Assembly



Detail A Takeup Base Gear Assembly (See Figure 2, Page 2 of 2)



Detail B Contact Brush Assembly

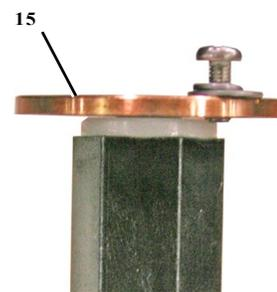

Detail C Rotary Fitting Plate Support Assembly

Figure 13. Table Assembly

Item	Part Number	Description
1A	119006	Take-up Base Assembly For Next Higher Assembly, See Figure 1.
1	118452-103K	Contact Brush Assembly
2	806691-04	Hole Plug
3	806586-04010	Socket Head Cap Screw, M4 x 0.7 x 10 mm
4	106860	Base Plate
5	806584-10035	Socket Head Cap Screw, M10 x 1.5 x 35 mm
6	106833	Upper Grease Cover
7	106908-01	Upper Grease Cover Guard
8	1806276	Self Tapping Phillips Pan Head Screw
9	005104	Grease Fitting, 1/8 NPT
10	106828	Rotary Base
11	106825-01	Base Gear
12	806584-10030	Socket Head Cap Screw, M10 x 1.5 x 30 mm
13	1806280-10	Hardened Flat Washer
14	106834	Lower Grease Cover
15	118803-01K	Rotary Fitting Plate Support Assembly
16	101621-01PKL	Bracket DR Kit (PL CR TU) SJ3/4AC/DI3 *NOT PICTURED ON PREVIOUS PAGE*
17	119110-900WMOT 106793-01 106871 108001-01	FRAME SJ4AC/DI3 ASSY WIRE RACE GRO 21-24 CTR ROLL (For Pattern Fabrics Only) TIE BASE LEG SJ4AC/DELTA PAD MACHINE SJ4/DELTA KB KIT PLATE ADPTR (PL CR TU)
18	119110-905WMOT 106793-01 106871 108001-01	FRAME SJ4AC/DI3 ASSY WIRE RACE GP 5 26"- 30" CTR ROLL (For Pattern Fabrics Only) TIE BASE LEG SJ4AC/DELTA PAD MACHINE SJ4/DELTA KB KIT PLATE ADPTR (PL CR TU) SJ4/4A/DI3FRAME
19	119110-901WMOT 103600-00PL 106871-PL	FRAME SJ4AC/DI3 ASSY WIRE RACE GP1 16"- 20" CTR ROLL (For Plain Jersey Fabrics) TIE BASE LEG GP1 SJ4A/DI3 PAD MACHINE GP1 SJ4A/DI3
20	119110-902WMOT 103600-01PL 106871-PL	FRAME SJ4AC/DI3 ASSY WIRE RACE GP2 11"- 15" CTR ROLL (For Plain Jersey Fabrics) TIE BASE LEG GP2 SJ4A/DI3 PAD MACHINE GP2 SJ4A/DI3

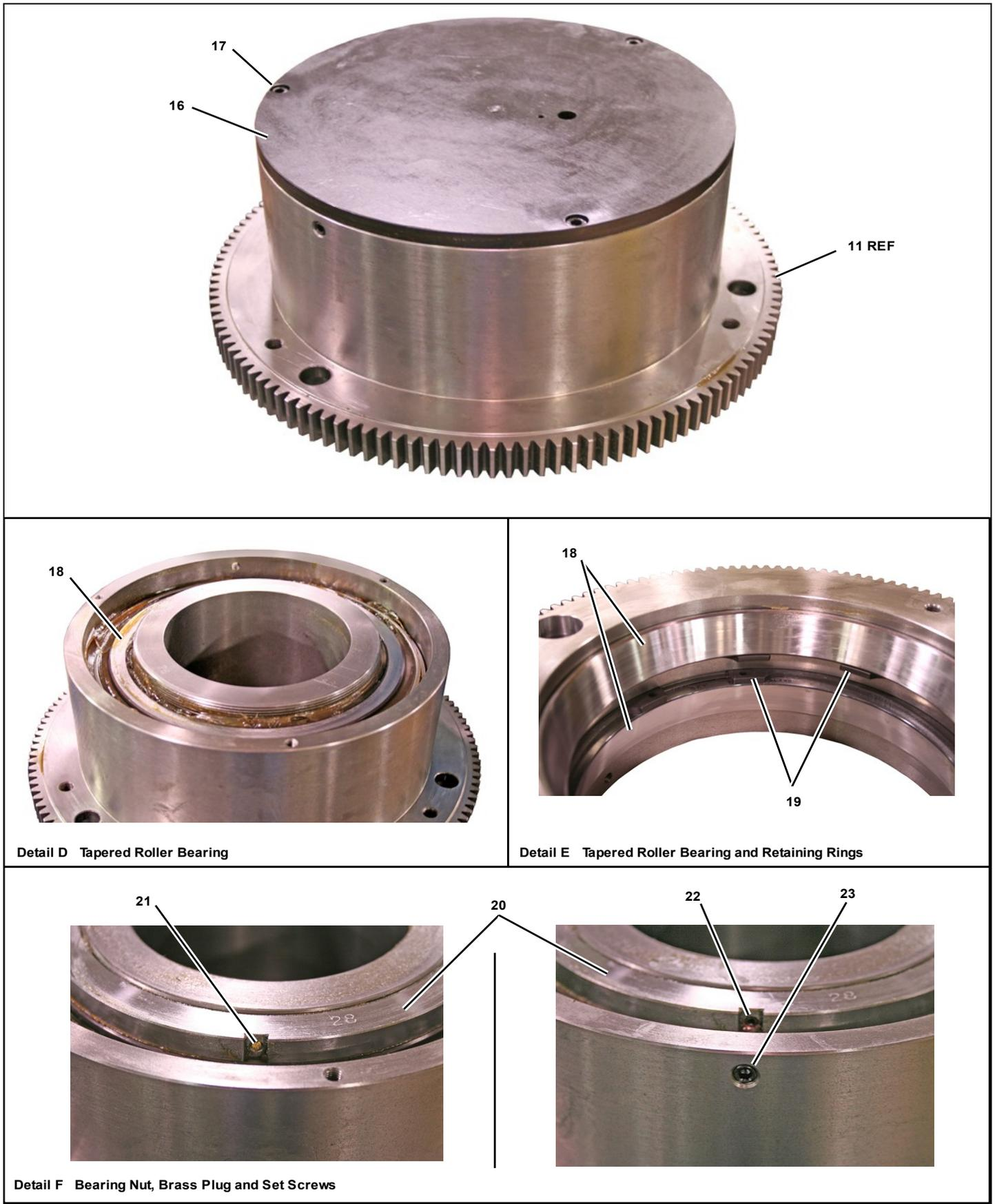

Figure 13. Table Assembly
(Page 2 of 2)

Item	Part Number	Description
16	106832	Base Bottom Cover
17	806584-06016	Socket Head Cap Screw, M6 x 1.0 x 16 mm
18	1806265	Tapered Roller Bearing
19	806419-900	Internal Retaining Ring
20	106842	Bearing Nut
21	005170-01	Brass Plug
22	1806269N	Flat Point Socket Head Set Screw, 10-32 x .25 in.
23	806590-0808	Socket Head Set Screw, M8 x 1.25 x 8 mm

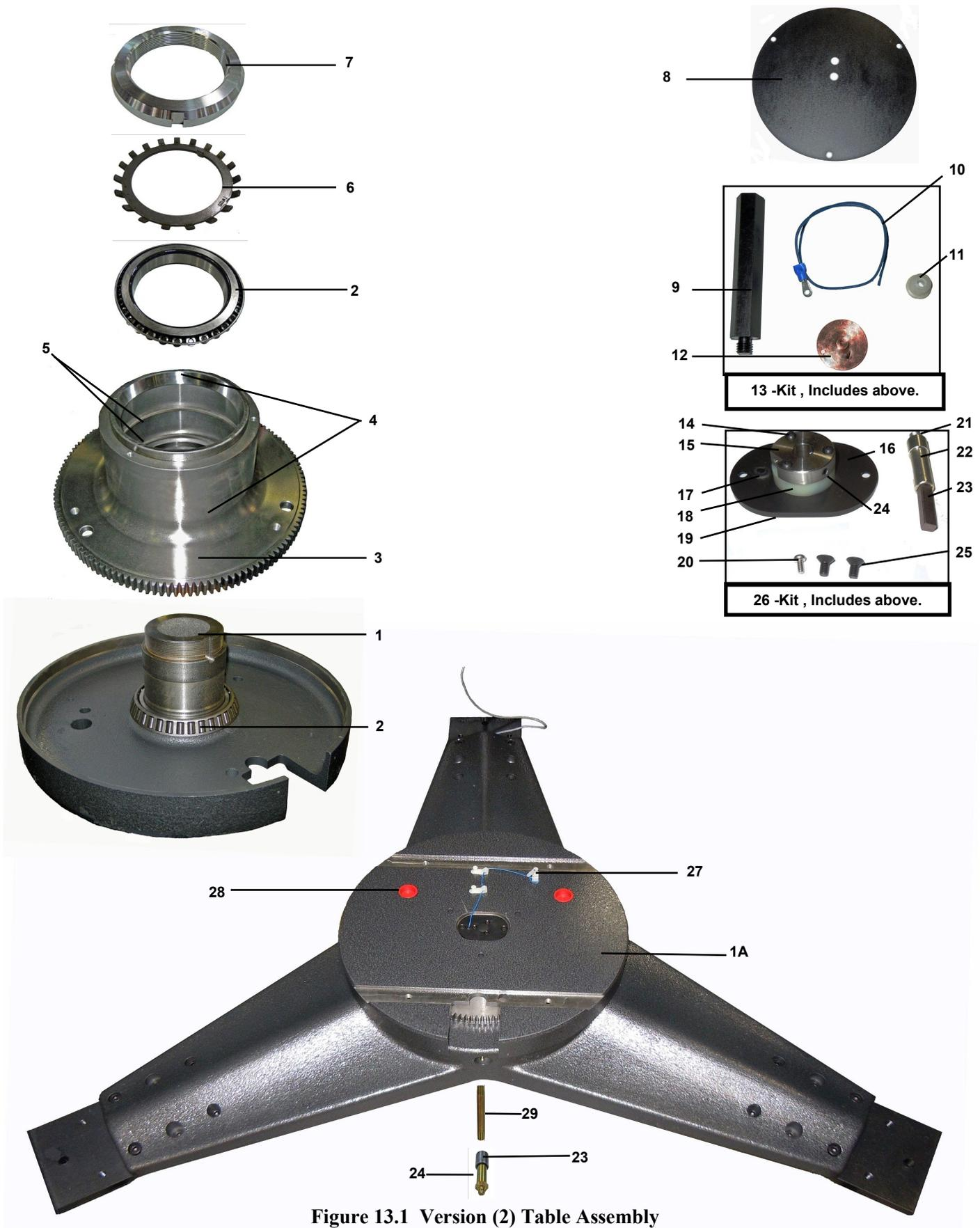
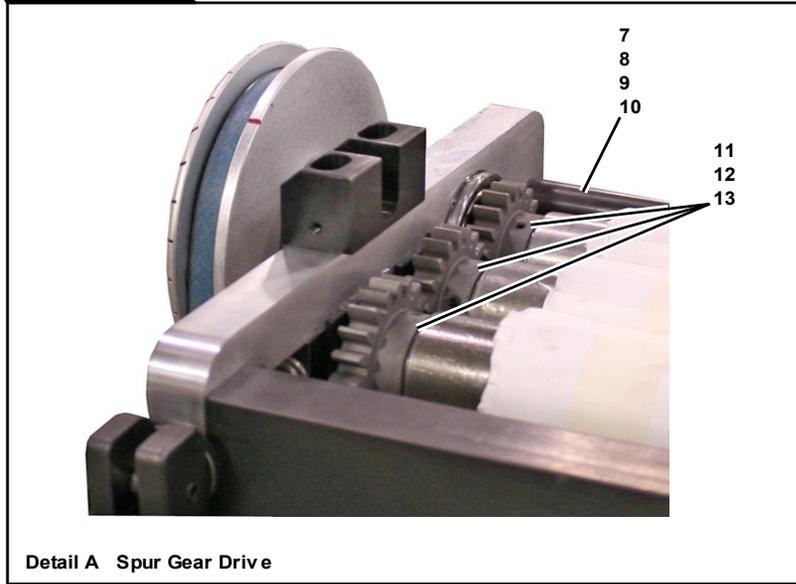

Figure 13.1 Version (2) Table Assembly

Item	Part Number	Description
1A	119006-01	Table Assembly
1	108106	Table, T/U
2	005131	Bearing, Cone, Large
3	106825-02	Gear T/U Base SJ4A/D SK
4	005132	Cup, Large
5	1806347-625	Ring, Ret Int Bev 6.25"
6	1806339	Lock washer
7	1806338	Locknut
8	108107	Cover, Base
9	103211-01	Post RTRY FTG, SJ4A/D
10	775514-186	Wire, Hook up 105 Deg
11	103212	Insulator, RTRY, FTG 3 RL
12	775576-14	Contact, Brush, Plate
13	118803-01K	Kit, Support RTSY/FTG
14	806587-03012	Screw Cap SKT BTNHD M3X (3 per Assy.)
15	105939-02	Brush Holder
16	103213-02	Plate Brush Mtg.
17	806509-13	Grommet , Rubber
18	105939-01	Spacer, Brush Insulating
19	806586-03006	Screw, Cap Skt CSKH M3X (3 per Assy.)
20	806588-03008	Screw Mach. PNH SLTD M3X
21	103213-02	Cover, Brush, Ftg
22	775576-112	Holder, Brush Assy
23	775576-111	Brush , Contact Assy
24	806592-0306	Screw Skt Set Cup Pt. M3
25	806586-04010	Screw, Cap Skt CSKH M4x
26	118452-103K	(Kit) Contact Brush Assy.
27	006876	Clamp
28	805603	Plug
29	1806367	Extension
30	1806350	Pipe, Coupling
31	806950-01	Grease Fitting

Top Rollers and Supports



Bottom Rollers, Supports, Drive Assembly, and Worm Gear Assembly

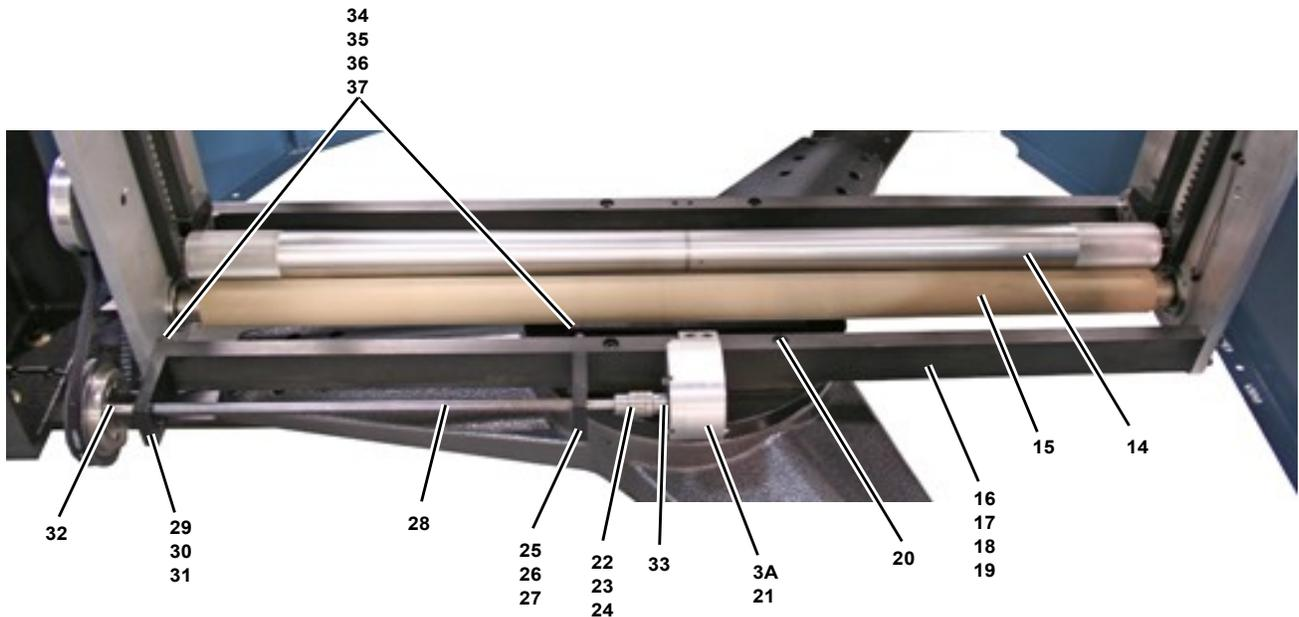

Figure 14. Take up Drive Assembly and Rollers

Item	Part Number	Description
1A	No P/N	Takeup Drive Assembly and Rollers For Next Higher Assembly, See Figure 1.
2A	119035-1GP 119035-2GP	Drive Shaft Assembly With One Way Clutch Ball Bearing Without One Way Clutch Ball Bearing Includes Items 22 thru 34
3A	118993-01	Worm Gear Assembly See Figure 10. For Illustrated Parts Breakdown
1	119030-GP 119030-1GP	Top Drive Roller Assembly Old Style with Clutch Bearing on Takeup Drive Shaft New Style with Clutch Bearing on Takeup Drive Roller
2	119031-GP	Top Driven Roller Assembly
3	106911-GP	Top Tie Bar
4	806584-06035	Socket Head Cap Screw, M6 x 1 x 35 mm
5	806596-06	Flat Washer, M6
6	806597-06	Lock Washer, M6
7	106912-GP	Top Tie Rod
8	806596-12	Flat Washer, M12
9	806597-12	Lock Washer, M12
10	806594-12	Hex Nut, M12 x 1.75
11	106906	Spur Gear
12	106943	Square Key, 0.125 x 0.125 x .425 in.
13	806590-0405	Socket Head Set Screw, M4 x .7 x 5 mm
14	119050-1GP 119070-GP	Elevating Roller Rack and Pinion Style Tapered Style
15	119033-GP	Bottom Friction Drive Roller
16	106827-GP	Bottom Support Bar
17	806584-08035	Socket Head Cap Screw, M8 x 1.25 x 35 mm
18	806596-08	Flat Washer, M8
19	806597-08	Lock Washer, M8
20	806584-10060	Socket Head Cap Screw, M10 x 1.5 x 60 mm
21	806587-08016	Button Head Cap Screw, M8 x 1.25 x 16 mm
22	1806284	Coupling (2 pieces required)
23	106943	Square Key, 0.125 x 0.125 x .425 in.
24	1806290	Coupling Insert
25	106918-02	Bearing Housing
26	1806291	Ball Bearing
27	806419-137	Retaining Ring
28	106916-1GP	Drive Shaft
29	106918-02	Bearing Housing
30	806195-03 1806291	Ball Bearing Clutch Style (one way rotation) Standard (rotates both ways)
31	806419-137	Retaining Ring
32	106943-01	Square Key, 0.125 x 0.125 x 1.250 in.
33	6172	Flat Washer, 1/2"
34	106994-KIT	Shim Kit
35	806584-06040	Socket Head Cap Screw, M6 x 1 x 40 mm
36	806596-06	Flat Washer, M6
37	806597-06	Lock Washer, M6

Roller Release Ratchet Assembly

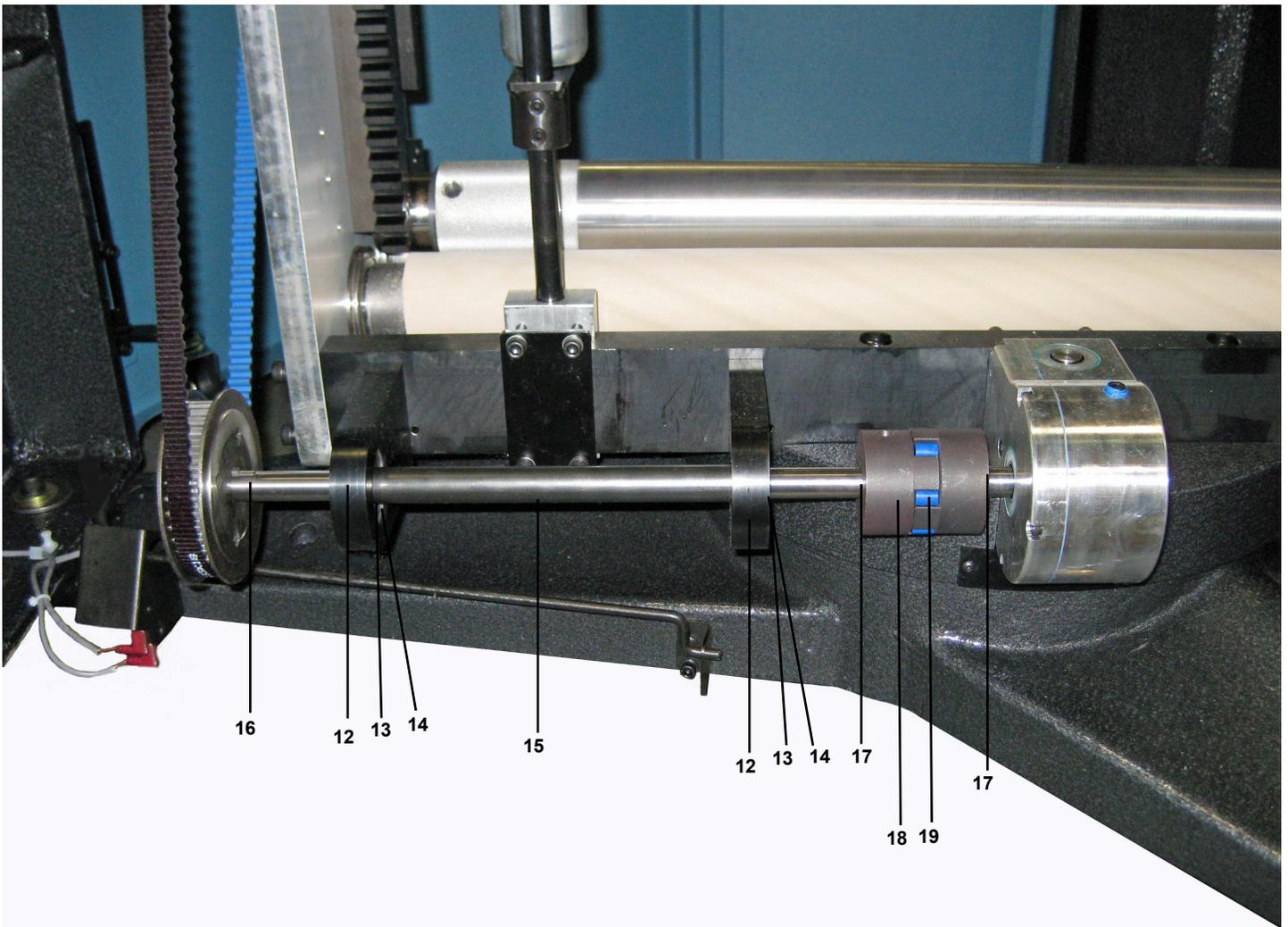
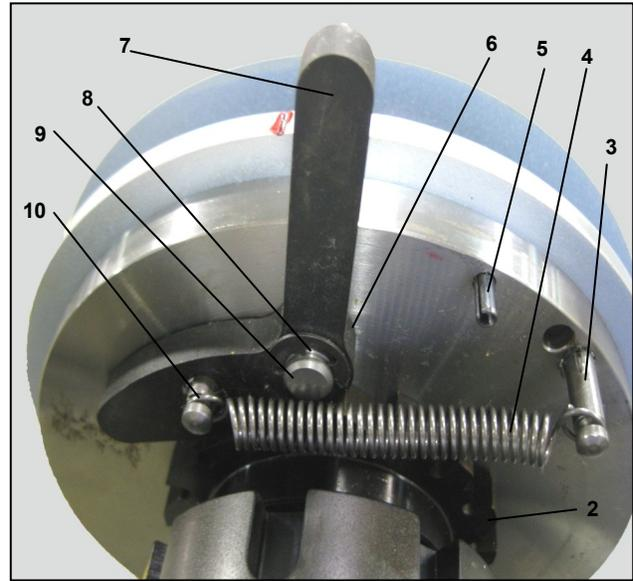
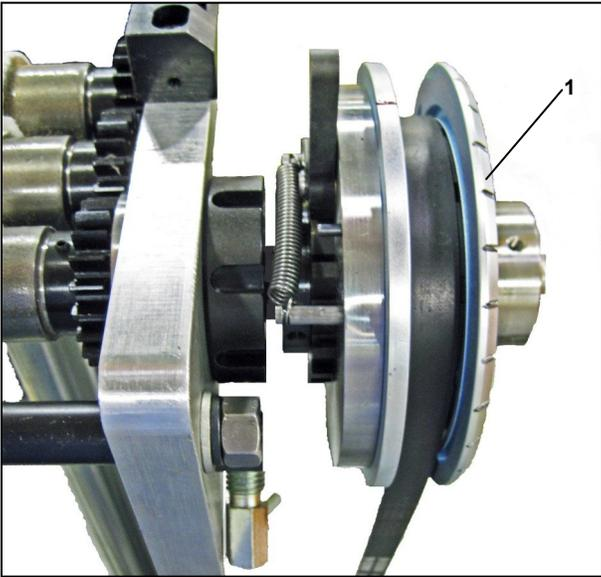

Figure 14A. Version 2 Take Up Drive Assembly

Item	Part Number	Description
1	119049-02	Upper Quality Wheel Assembly
2	108111	Ratchet
3	1806359-05020	Groove Pin
4	005156-01	Spring
5	805346	Roll Pin
6	106899-006	Shim
7	108110	Pawl
8	806368-0310	Retaining Ring
9	108151	Pivot Pin
10	108159-05012	Groove Pin
11	119035-3GP	Version 2 Shaft T/U DR Assy-Delta T/U (Items 12—
12	106918-03	Housing T/U DR SFT BRG+BSHGS
13	1806343	Bearing Ball-SJ4A/D SKB
14	806419-156	Ring Ret 1,575" Bore SJ4A/D
15	106916-2GP	Shaft T/U DR—SJ4A/D SKB
16	108130-01	Key SQ 3/16 X 1.00
17	108130-02	Key SQ 3/16 X .750
18	1806346	Coupling T/U DR SFT-SJ4A/D S
19	1806366	Insert Coupling Urethane SKB
	806385-19	Loctite 7649 Primer
	806385-20	Loctite 609 Rtng Cmpd

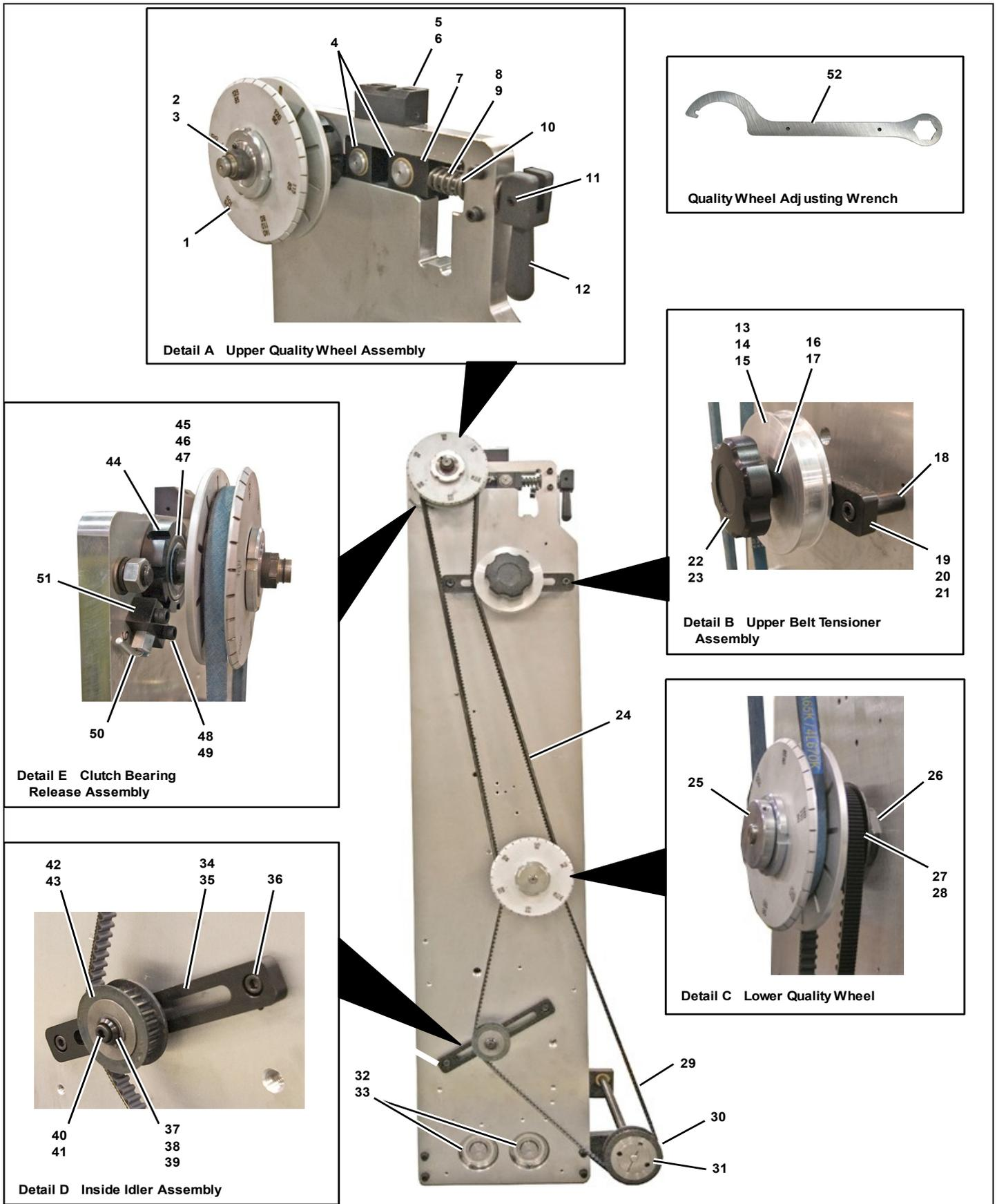
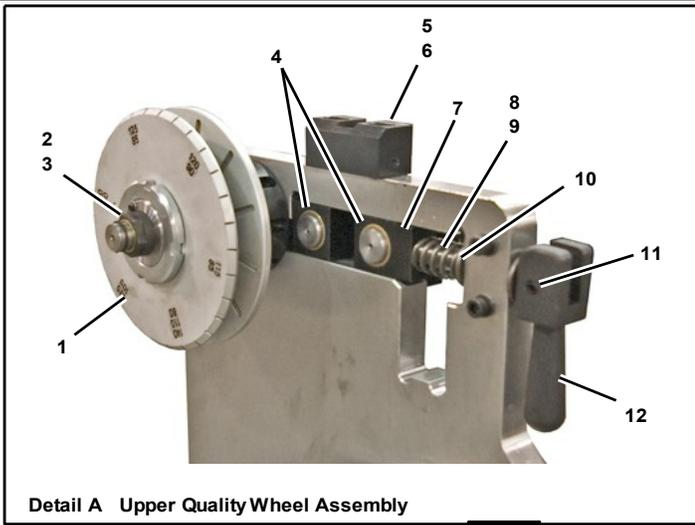
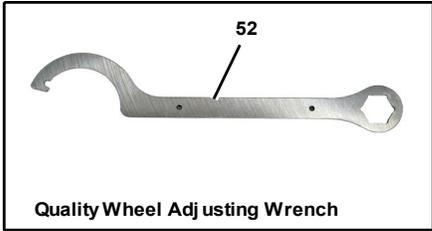

Figure 15. Drive Sidewall Assembly (New Style)

Item	Part Number	Description
1A	No P/N	Drive Sidewall Assembly (New Style) For Next Higher Assembly, See Figure 1.
1	119049-01	Upper Quality Wheel
	106947	Segmental Sheave Block Kit (Not Shown)
	101816	Segmental Sheave Block Cushion (Not Shown)
2	1806020-760	Trantorque Coupling
3	6881	Retaining Ring
4	119032	Bearing Block Assembly
5	101618-03	Drive Block
6	806584-06025	Socket head Cap Screw, M6 x 1 x 25 mm
7	101804	Nut Plate
8	101803	Compression Spring
9	101738-01	Pressure Adjusting Screw
10	006172	Flat Washer, 1/2 in.
11	806600-06026	Roll Pin, M6 x 26 mm
12	101767	Pressure Release Handle
13	118994-01	Backside Idler Assembly Includes Items 14, 15, 16, 17, 19, and 23
14	106319-03	Pulley
15	1806254	Bearing
16	106854	Idler Shaft
17	806192-20	Retaining Ring
18	108028	Spacer
19	106845	Plate
20	806584-08050	Socket Head Cap Screw, M8 x 1.25 x 50 mm
21	806597-08	Lock Washer, M8
22	1806285-01	Knob
23	106843	Nut Plate
24		V-Belt, Kevlar
	1806282-46	Used on Industrial Height on All Groups 0 and 1
	1806282-65	Used on Jumbo Height Groups 0 and 1
	1806282-71	Used on Jumbo Height Groups 2 and 3
25	119048	Lower Quality Wheel
	106947	Segmental Sheave Block Kit (Not Shown)
	101816	Segmental Sheave Block Cushion (Not Shown)
26	106821	Mounting Post
27		Driven Pulley
	806677-28	28 Teeth
	806677-36	36 Teeth
	806677-42	42 Teeth
28		Taper Lock Bushing
	806667-28	Use with 28 Tooth Sprocket
	1806187-28	Use with 36 Tooth Sprocket
	1806186-28	Use with 42 Tooth Sprocket
29	806670-1440	Belt
30		Drive Sprocket
	806677-28	28 Teeth
	806677-36	36 Teeth
	806677-42	42 Teeth



Detail A Upper Quality Wheel Assembly



Quality Wheel Adjusting Wrench

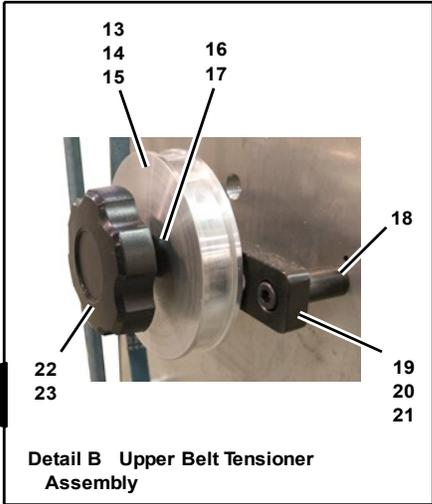

Detail B Upper Belt Tensioner Assembly

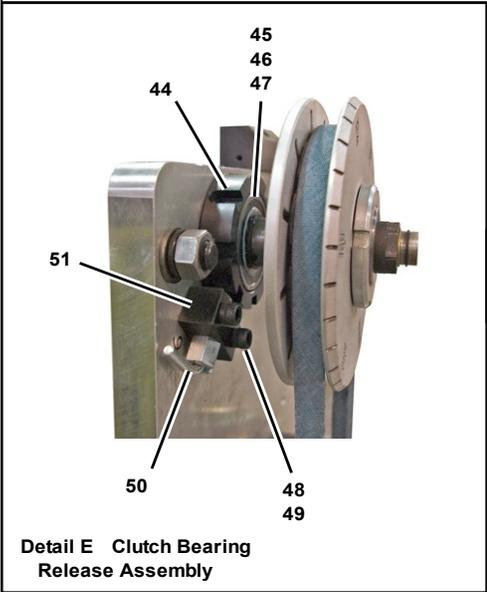

Detail E Clutch Bearing Release Assembly

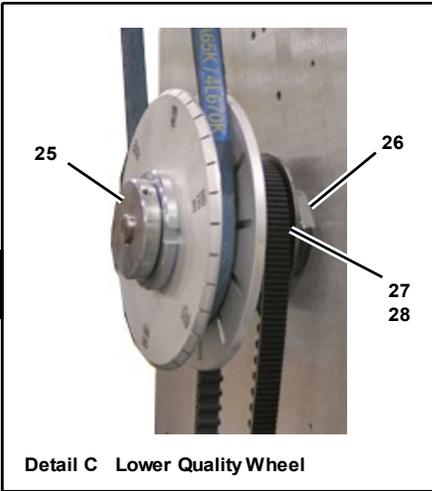

Detail C Lower Quality Wheel

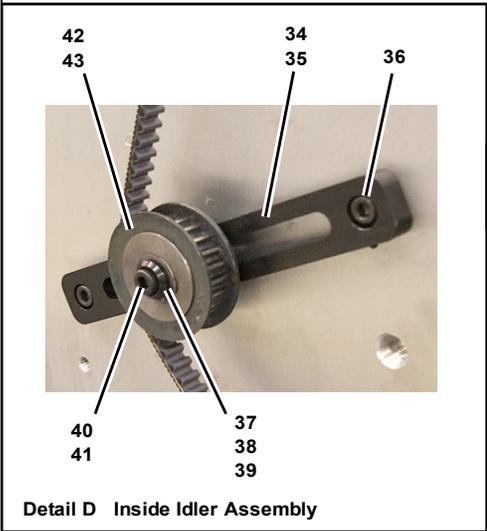

Detail D Inside Idler Assembly

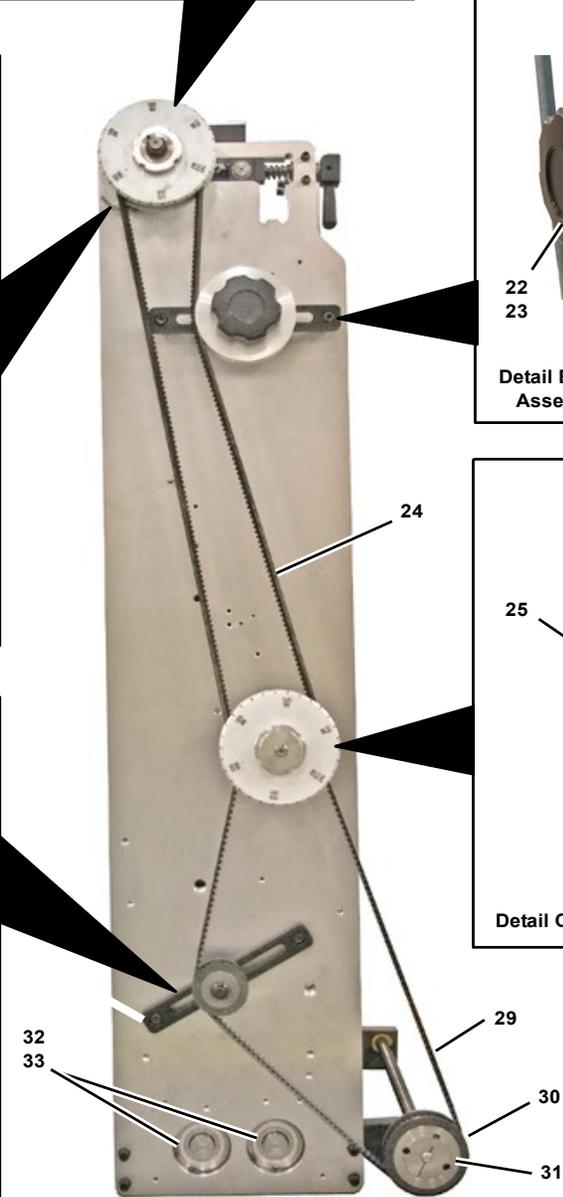

Item	Part Number	Description
31	806667-127 1806187-127 1806186-127	Taper Lock Bushing Use with 28 Tooth Sprocket Use with 36 Tooth Sprocket Use with 42 Tooth Sprocket
32	1806064-13072	Ball Bearing
33	806419-281	Retaining Ring
34	118994	Inside Idler Assembly (Includes Items 35 thru 43)
35	106845	Plate
36	806584-08020	Socket Head Cap Screw, M8 x 1.25 x 20 mm
37	106854	Shaft
38	106843	Nut
39	806192-20	Retaining Ring
40	806584-08035	Socket Head Cap Screw, M8 x 1.25 x 35 mm
41	806597-08	Lock Washer, M8
42	106866-22	Sprocket, 22 Teeth
43	1806254	Bearing
44	108106	Clutch Bearing Housing
45	806195-04	Clutch Bearing
46	806980-0805016	Rectangular Key, 8mm x Mmm x 16 mm
47	806192-098	Retaining Ring
48	806584-06025	Socket Head Cap Screw, M6 x 1 x 25 mm
49	806597-06	Lock Washer, M6
50	1806307	Spring Plunger
51	108017	Mounting Block
52	108036	Spanner and 22 mm Box End Wrench
*42	106866-122	Sprocket 22 Teeth Special (New Style) After 4/23/2011
*43	806943	Bearing (New Style) After 4/23/2011

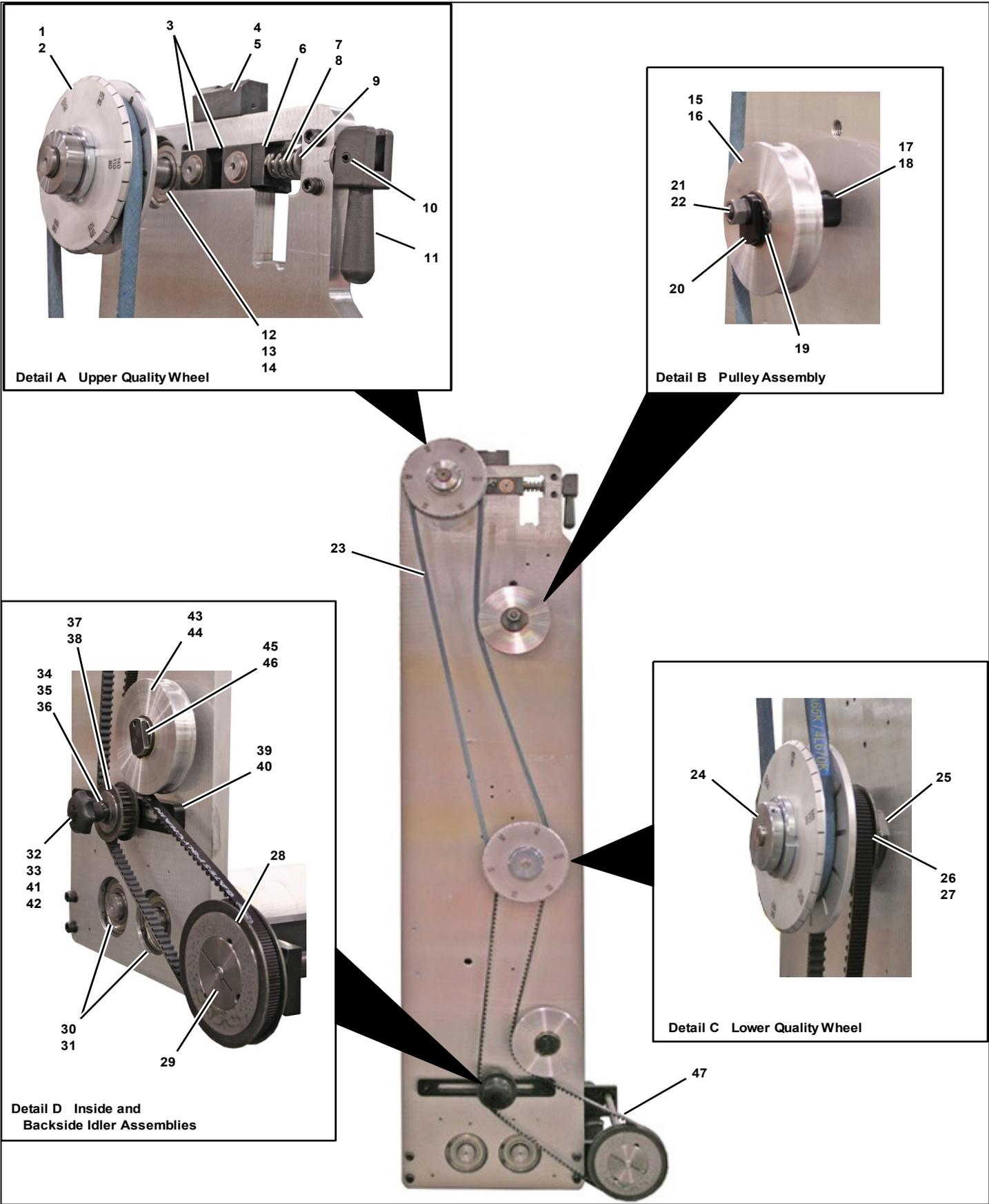

Figure 16. Drive Sidewall Assembly (Old Style)

Item	Part Number	Description
1A	No P/N	Drive Sidewall Assembly (Old Style) For Next Higher Assembly, See Figure 1.
1	119049	Upper Quality Wheel
	106947	Segmental Sheave Block Kit (Not Shown)
	101816	Segmental Sheave Block Cushion (Not Shown)
2	106943-01	Square Key, 0.125 x 0.125 x 1.25 in.
3	119032	Bearing Block Assembly
4	101618-03	Drive Block
5	806584-06025	Socket head Cap Screw, M6 x 1 x 25 mm
6	101804	Nut Plate
7	101803	Compression Spring
8	101738-01	Pressure Adjusting Screw
9	006172	Flat Washer, 1/2 in.
10	806600-06026	Roll Pin, M6 x 26 mm
11	101767	Pressure Release Handle
12	806419-244	Retaining Ring
13	1806064-12562	Ball Bearing without Retaining Ring
14	806192-098	Retaining Ring (Behind Bearing)
15	118805-05	Pulley Assembly (Includes Items 16 thru 22)
16	106323-01	Pulley
17	106320-02	Mounting Post
18	006802	Roll Pin, 0.125 x 0.625 in.
19	806192-150	Retaining Ring
20	106321-01	Eccentric Hub
21	806594-12	Hex Nut, M12 x 1.75
22	806597-12	Lock Washer, M12
23	1806282-65	V-Belt, Kevlar
24	119048	Lower Quality Wheel
	106947	Segmental Sheave Block Kit (Not Shown)
	101816	Segmental Sheave Block Cushion (Not Shown)
25	106821	Mounting Post
26		Driven Pulley
	806677-28	28 Teeth
	806677-36	36 Teeth
	806677-42	42 Teeth
27		Taper Lock Bushing
	806667-28	Use with 28 Tooth Sprocket
	1806187-28	Use with 36 Tooth Sprocket
	1806186-28	Use with 42 Tooth Sprocket
28		Drive Sprocket
	806677-28	28 Teeth
	806677-36	36 Teeth
	806677-42	42 Teeth
29		Taper Lock Bushing
	806667-127	Use with 28 Tooth Sprocket
	1806187-127	Use with 36 Tooth Sprocket
	1806186-127	Use with 42 Tooth Sprocket
30	1806064-13072	Ball Bearing
31	806419-281	Retaining Ring
32	118994	Inside Idler Assembly (Includes Items 33 thru 40)
33	806597-08	Lock Washer, M8
34	106854	Shaft

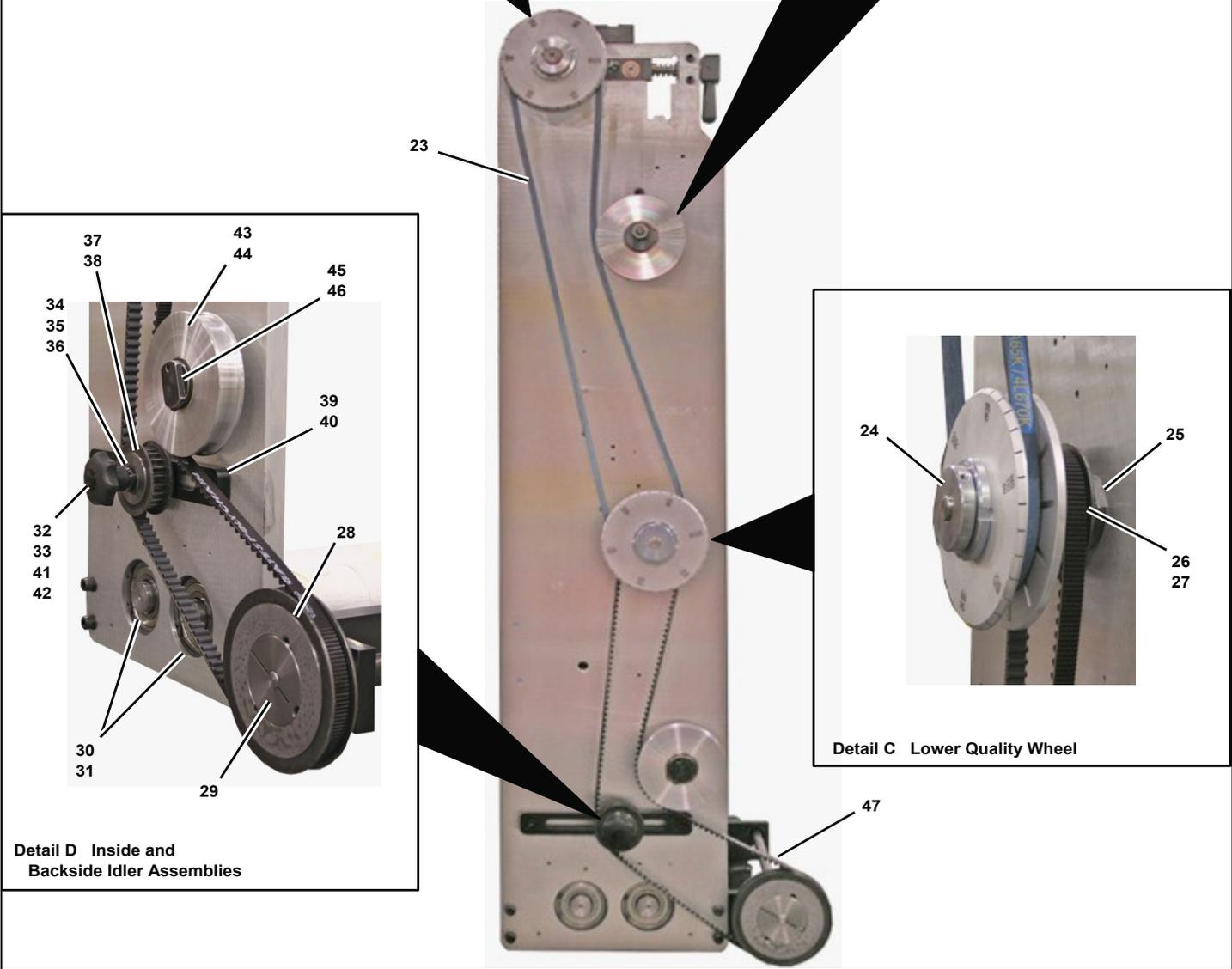
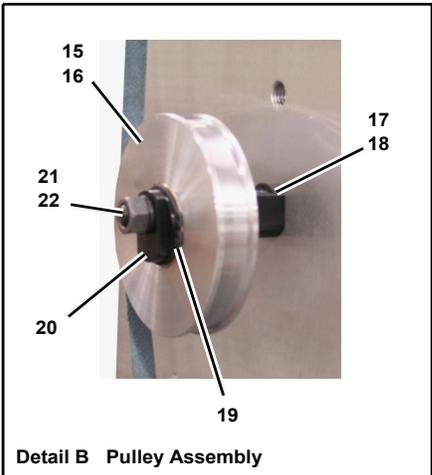
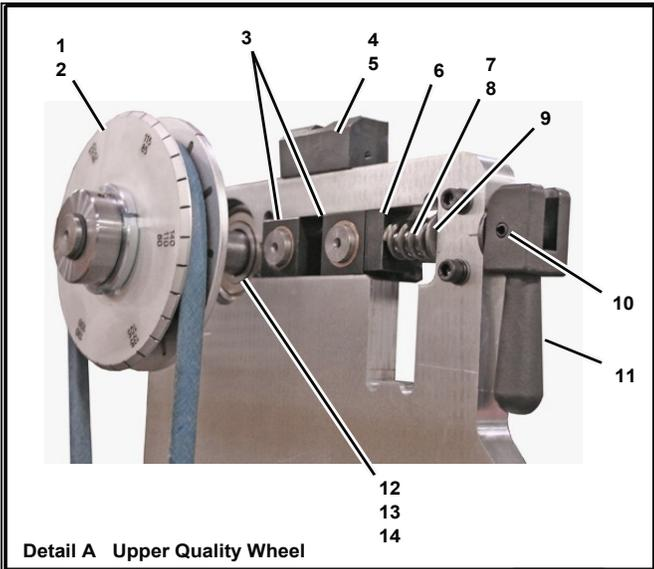

Figure 16. Drive Sidewall Assembly (Old Style)

Item	Part Number	Description
35	106843	Nut
36	806192-20	Retaining Ring
37	106866-22	Sprocket, 22 Teeth
38	1806254	Bearing (Inside Sprocket)
39	106845	Plate
40	806584-08020	Socket Head Cap Screw, M8 x 1.25 x 20 mm
41	1806285	Knob
42	1806286	Hex Head Cap Screw, M8 x 1.25 x 60 mm Full Thread
43	118995	Backside Idler Assembly (Includes Items 44 thru 46)
44	106323-01	Pulley Assembly
45	106822	Shaft
46	806192-150	Retaining Ring
47	806670-1600	Belt

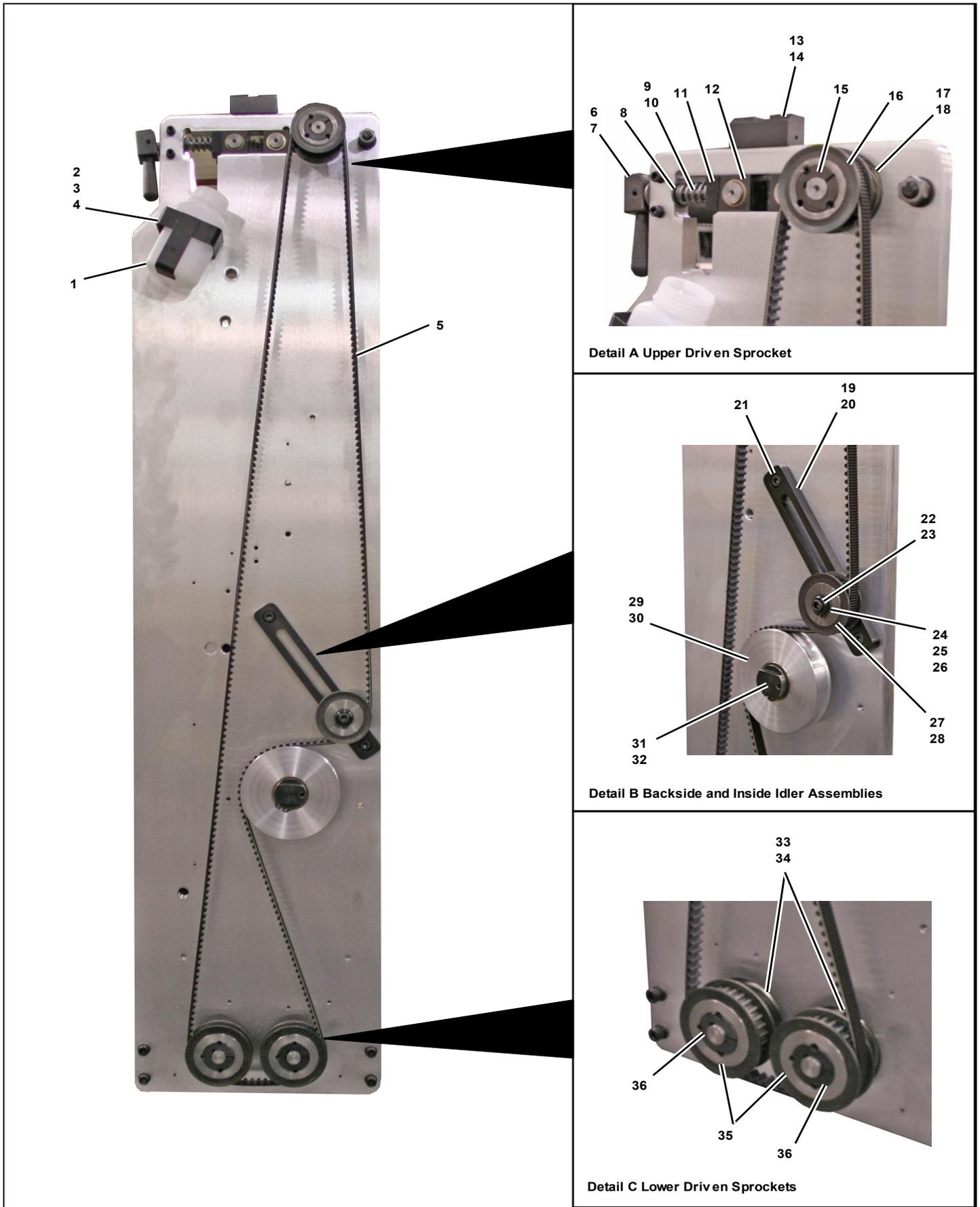

Figure 17. Driven Sidewall Assembly

Item	Part Number	Description
1A	No P/N	Driven Sidewall Assembly For Next Higher Assembly, See Figure 1.
1		Sump Bottle
	806187-02	8 Ounces
	806187-01	32 Ounces
2		Sump Bottle Holder
	101609-03	Used with 8 Ounce Bottle
	101609-01	Used with 32 Ounce Bottle
3	806587-04008	Button Head Cap Screw, M4 x .7 x 8 mm
4	806606-04	Lock Washer, M4
5		Driven Belt
	806670-2800	35 in. Industrial (All Groups) and 45 in. Jumbo (Groups 0 and 1)
	8066770-3280	48 in. Jumbo (Groups 2 and 3)
6	101767	Pressure Release Handle
7	806600-06026	Roll Pin, M6 x 26 mm
8	006172	Flat Washer, 1/2 in.
9	101803	Compression Spring
10	101738-01	Pressure Adjusting Screw
11	101804	Nut Plate
12	119032	Bearing Block Assembly
13	101618-03	Drive Block
14	806584-06025	Socket Head Cap Screw, M6 x 1 x 25 mm
15	806667-017	Bushing, TL1008, 17 mm Bore x 5 mm Key
16	806677-22	Sprocket, 22 Teeth
17	1806064-12562	Ball Bearing with Retaining Ring
18	806192-098	Retaining Ring (Behind Bearing)
19	118994	Inside Idler Assembly (Includes Items 20 thru 28)
20	106845	Plate
21	806584-08020	Socket Head Cap Screw, M8 x 1.25 x 20 mm
22	806584-08035	Socket Head Cap Screw, M8 x 1.25 x 35 mm
23	806597-08	Lock Washer, M8
24	106854	Shaft
25	106843	Nut
26	806192-20	Retaining Ring
27	106866-22	Sprocket, 22 Teeth
28	1806254	Bearing
29	118995	Backside Idler Assembly (Includes Items 30 thru 32)
30	106323-01	Pulley Assembly
31	106822	Shaft
32	806192-150	Retaining Ring (Behind Bearing)
33	1806064-13072	Ball Bearing
34	806419-281	Retaining Ring
35	806677-28	Sprocket, 28 Teeth
36	806667-117	Bushing, TL1108, 17 mm Bore x 5 mm Key
*27	106866-122	Sprocket 22 Teeth Special (New Style) After 4/23/2011
*28	806943	Bearing (New Style) After 4/23/2011

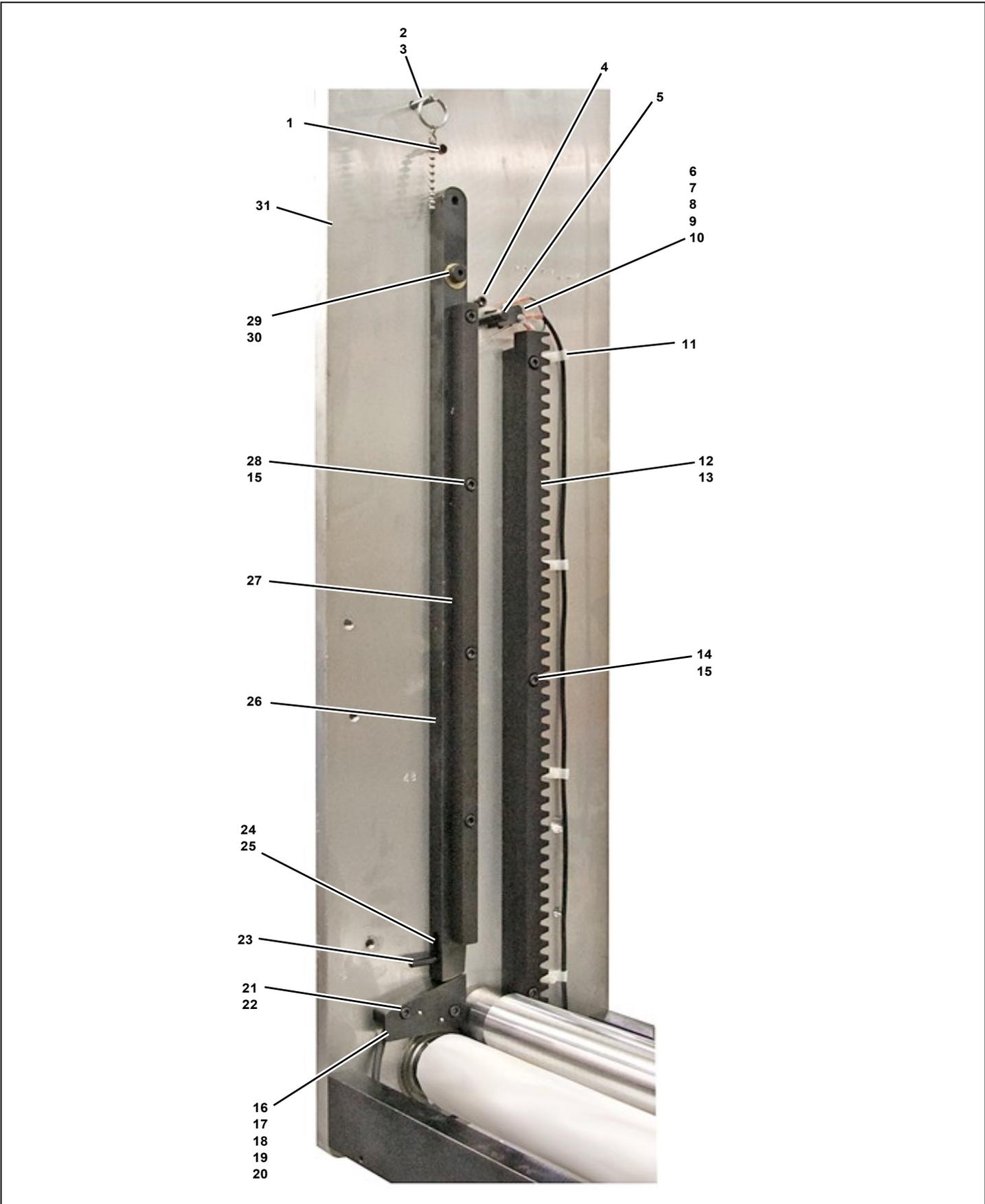

Figure 18. Swing Arm Assembly with Tapered Elevating Roller

Item	Part Number	Description
1A	No P/N	Sidewall Assembly with Tapered Elevating Roller For Next Higher Assembly, See Figure 1.
1	806584-04018	Socket Head Cap Screw, M4 x .7 x 18 mm
2	1806288	Beaded Lanyard
3	006947-01	Quick Release Pin
4	806584-06012	Socket Head Cap Screw, M6 x 1 x 12 mm
5	104499	Stop Post
6	104350	Switch Mounting Plate
7	806586-04012	Flat Socket Head Cap Screw, M4 x .7 x 12 mm
8	775516	Microswitch
9	806588-25016	Pan Head Screw, M2.5 x .45 x 16 mm
10	806598-25	Internal Tooth Lock Washer, M2.5
11	775516-100	Cable Clamp, 1/8" Loop
12		Roll Guide Spacer
	108012-35	35 inch Industrial Take-up
	108012-45	45 inch Jumbo Take-up, Groups 0 and 1
	108012-48	48 inch Jumbo Take-up, Groups 2 and 3
13		Gear Rack
	106641-06	35 inch Industrial Take-up
	106641-05	45 inch Jumbo Take-up, Groups 0 and 1
	106641-04	48 inch Jumbo Take-up, Groups 2 and 3
14	806584-06025	Socket Head cap Screw, M6 x 1 x 25 mm
15	806606-06	Lock Washer, M6
16		Bolt Receiver Ramp
	104309-01	Right Hand
	104308-01	Left Hand
17		Switch Cover
	104874-01	Right Hand
	104874-02	Left Hand
18	775533-01	Microswitch
19	806588-25016	Pan Head Screw, M2.5 x .45 x 16 mm
20	806598-25	Internal Tooth Lock washer, M2.5
21	806584-06025	Socket Head Cap Screw, M6 x 1 x 25 mm
22	806606-06	Lock Washer, M6
23	102586-02	Roll Release Pin
24	105885-01	Roll Release Bolt
25	806698-Z	Compression Spring
26		Roll Release Bar
	106859-35	35 inch Industrial Take-up
	106859-45	45 inch Jumbo Take-up, Groups 0 and 1
	106859-48	48 inch Jumbo Take-up, Groups 2 and 3
27		Roll Guide Bar
	108011-35	35 inch Industrial Take-up
	108011-45	45 inch Jumbo Take-up, Groups 0 and 1
	108011-48	48 inch Jumbo Take-up, Groups 2 and 3
28	806584-06045	Socket Head Cap Screw, M6 x 1 x 45 mm
29	806601-08020	Socket Head Shoulder Screw, M8 x 1.25 x 20 mm
30	806663-04	Shim
31		Sidewall
	106814-35	35 inch Industrial Take-up
	106814-45	45 inch Jumbo Take-up, Groups 0 and 1
	106814-48	48 inch Jumbo Take-up, Groups 2 and 3

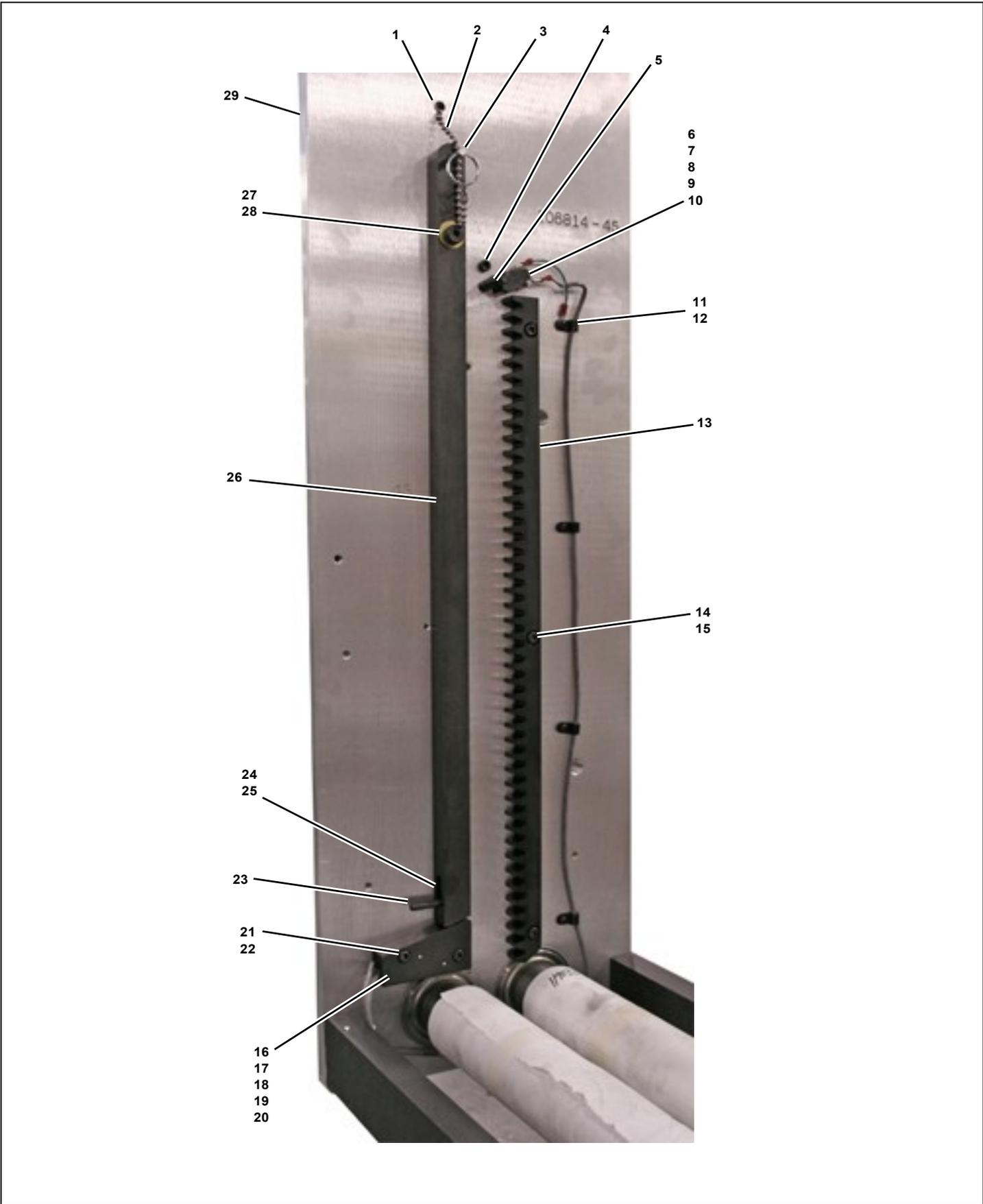
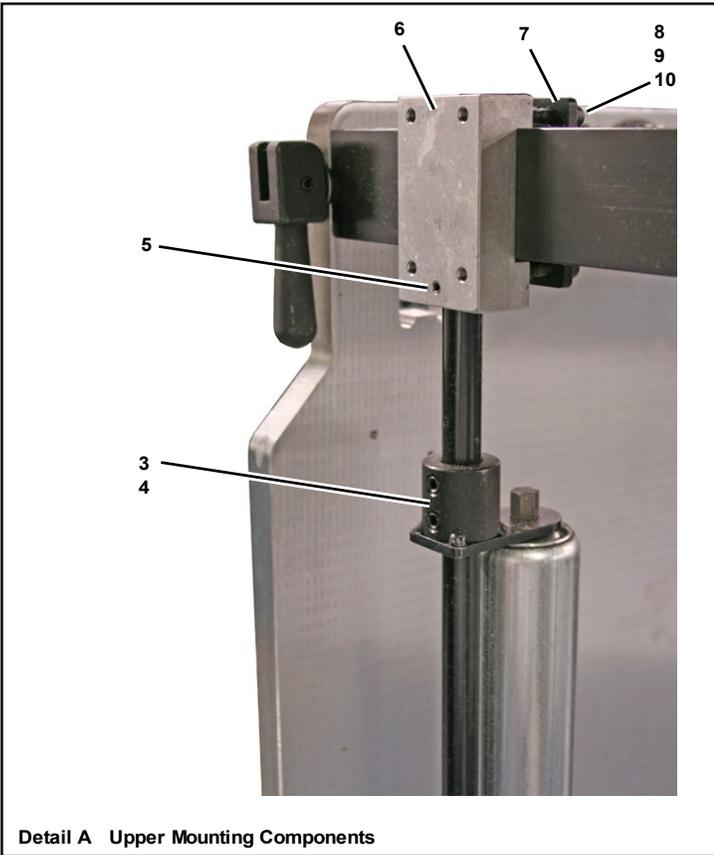
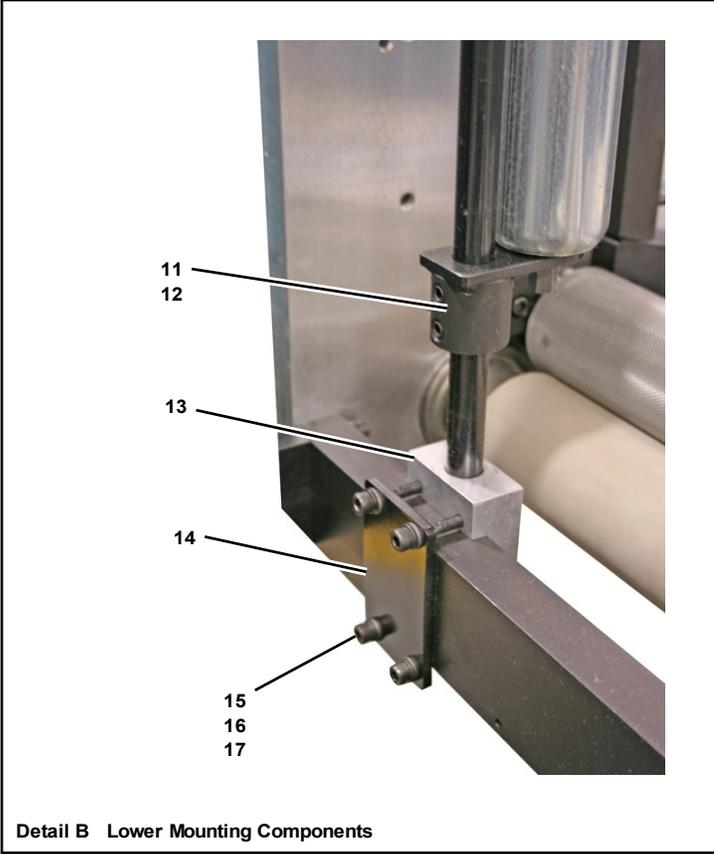
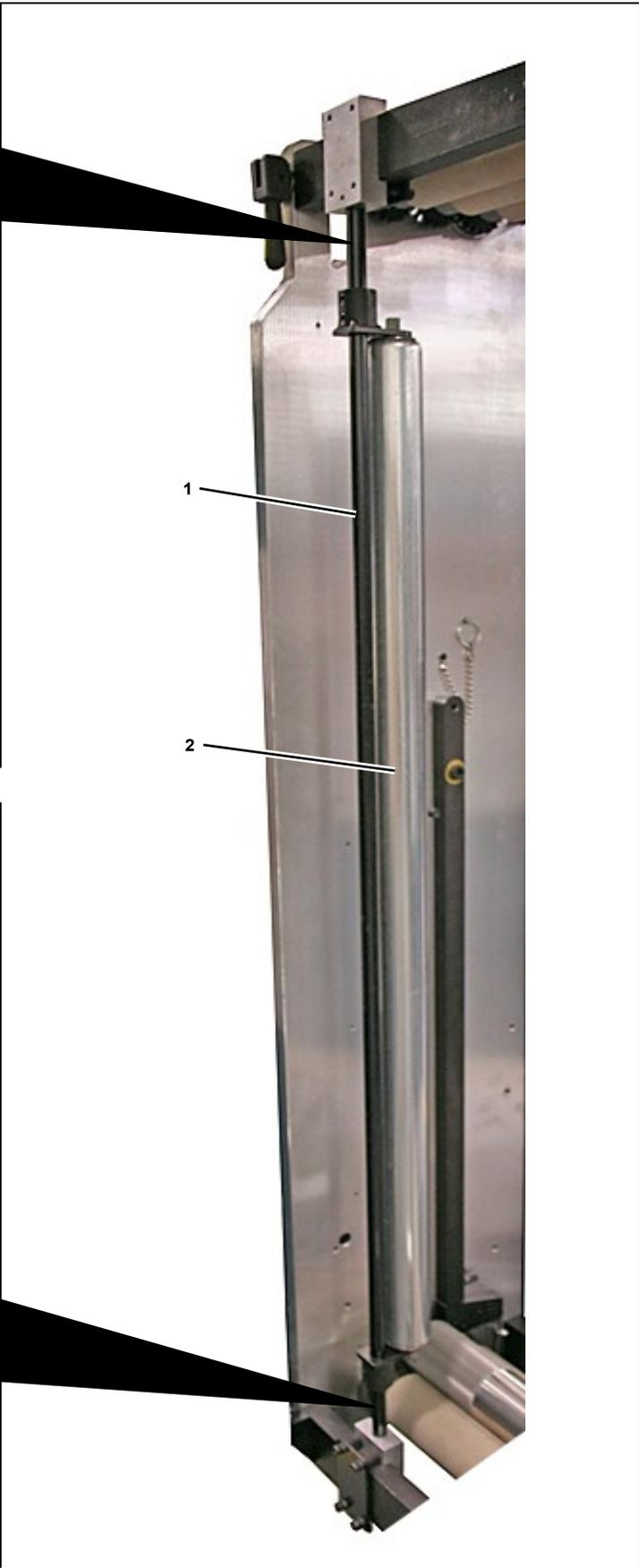

Figure 19. Swing Arm Assembly with Rack and Pinion Elevating Roller

Item	Part Number	Description
1A	No P/N	Sidewall Assembly with Rack and Pinion Elevating Roller For Next Higher Assembly, See Figure 1.
1	806584-04018	Socket Head Cap Screw, M4 x .7 x 18 mm
2	1806288	Beaded Lanyard
3	006947-01	Quick Release Pin
4	806584-06012	Socket Head Cap Screw, M6 x 1 x 12 mm
5	104499	Stop Post
6	104350	Switch Mounting Plate
7	806586-04012	Flat Socket Head Cap Screw, M4 x .7 x 12 mm
8	775516	Microswitch
9	806588-25016	Pan Head Screw, M2.5 x .45 x 16 mm
10	806598-25	Internal Tooth Lock Washer, M2.5
11	775516-04	Cable Clamp, 1/4" Loop
12	806584-04008	Button Head Cap Screw, M4 x .7 x 8 mm
13		Gear Rack
	106641-06	35 inch Industrial Take-up
	106641-05	45 inch Jumbo Take-up, Groups 0 and 1
	106641-04	48 inch Jumbo Take-up, Groups 2 and 3
14	806584-06025	Socket Head cap Screw, M6 x 1 x 25 mm
15	806606-06	Lock Washer, M6
16		Bolt Receiver Ramp
	104309-01	Right Hand
	104308-01	Left Hand
17		Switch Cover
	104874-01	Right Hand
	104874-02	Left Hand
18	775533-01	Microswitch
19	806588-25016	Pan Head Screw, M2.5 x .45 x 16 mm
20	806598-25	Internal Tooth Lock washer, M2.5
21	806584-06025	Socket Head Cap Screw, M6 x 1 x 25 mm
22	806606-06	Lock Washer, M6
23	102586-02	Roll Release Pin
24	105885-01	Roll Release Bolt
25	806698-Z	Compression Spring
26		Roll Release Bar
	106859-35	35 inch Industrial Take-up
	106859-45	45 inch Jumbo Take-up, Groups 0 and 1
	106859-48	48 inch Jumbo Take-up, Groups 2 and 3
27	806601-08020	Socket Head Shoulder Screw, M8 x 1.25 x 20 mm
28	806663-04	Shim
29		Sidewall
	106814-35	35 inch Industrial Take-up
	106814-45	45 inch Jumbo Take-up, Groups 0 and 1
	106814-48	48 inch Jumbo Take-up, Groups 2 and 3



Detail A Upper Mounting Components



Detail B Lower Mounting Components

Figure 20. Roll Containing Guide Assembly
(Groups 2 and 3 Only with 48" Roll Capacity)

Item	Part Number	Description
1A	119047B 119047A 119047	Roll Containing Guard Assembly Used on Group 1, 2, and 3 with 35" Roll Capacity Take-up Used on Group 1 with 45" Roll Capacity Take-up Used on Groups 2 and 3 with 48" Roll Capacity Take-up
1	105951-10 105951-09 105951-08	Guide Rod Used on Group 1, 2, and 3 with 35" Roll Capacity Take-up Used on Group 1 with 45" Roll Capacity Take-up Used on Groups 2 and 3 with 48" Roll Capacity Take-up
2	106934-30 106934	Roller Assembly Used on Group 1, 2, and 3 with 35" Roll Capacity Take-up Used on Group 1 with 45" Roll Capacity Take-up and Groups 2 and 3 with 48" Roll Capacity Take-up
3	106932A	Support Block
4	806592-0808	Socket Head Set Screw, M8 x 1.25 x 8 mm
5	006753	Roll Pin, 3/16 x 1 in.
6	106944-01	Upper Bracket
7	106945-01	Upper Clamp Bracket
8	806584-06040	Socket Head Cap Screw, M6 x 1 x 40 mm
9	806596-06	Flat Washer, M6
10	806597-06	Lock Washer, M6
11	106932A	Support Block
12	806592-0808	Socket Head Set Screw, M8 x 1.25 x 8 mm
13	106944-02	Lower Bracket
14	106945-02	Lower Clamp Bracket
15	806584-06040	Socket Head Cap Screw, M6 x 1 x 40 mm
16	806596-06	Flat Washer, M6
17	806597-06	Lock Washer, M6

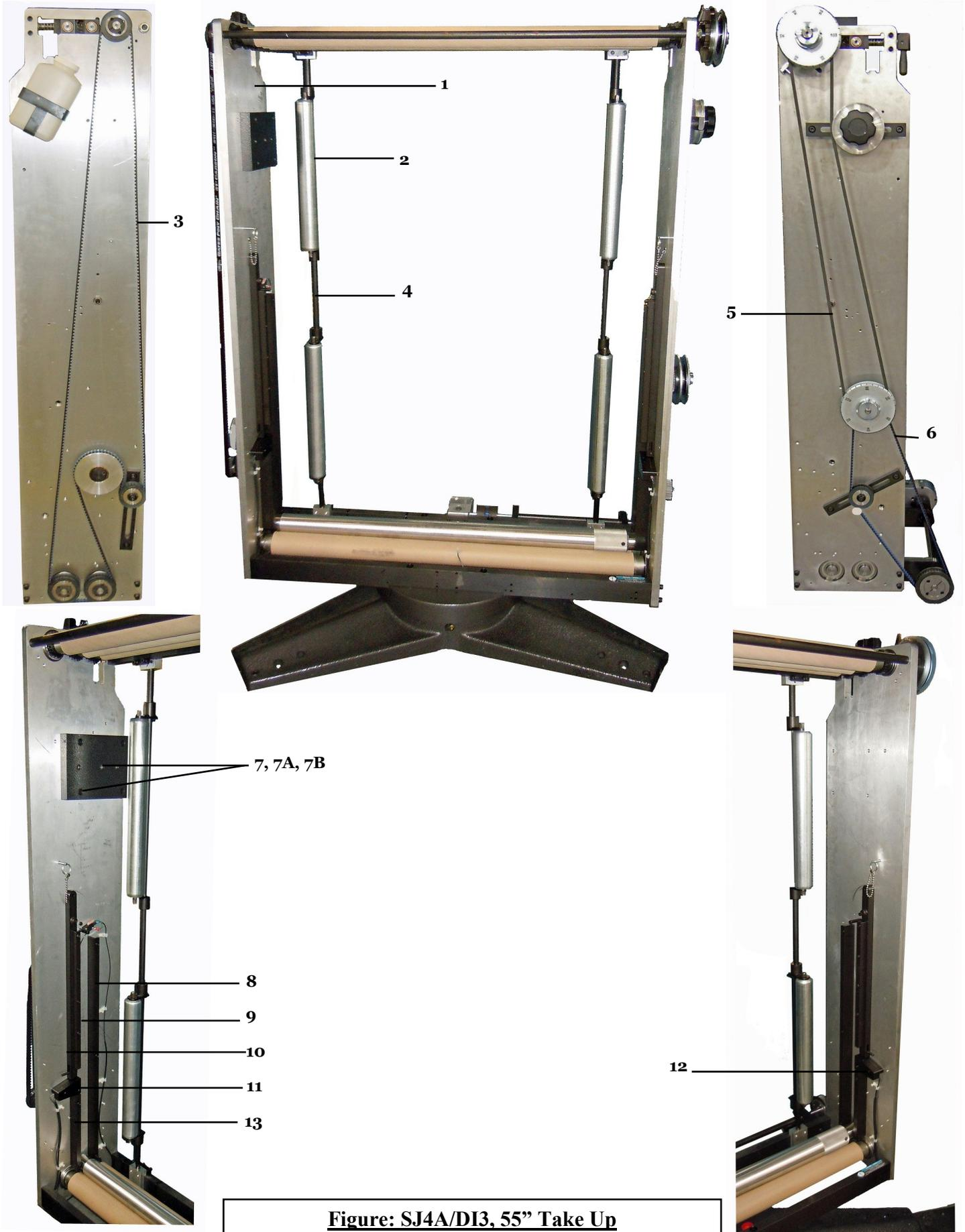

Figure: SJ4A/DI3, 55" Take Up

Item	Part Number	Description
1	106814-55	Wall, Take Up SJ4A/D 55 inch capacity
2	106934-17	Roller, Conveyor 1.9" Dia x 17" Long
3	806670-3600	Belt, Kevlar
4	105951-11	Rod, Take Up Guide, SJ4A/DI3 55" Capacity
5	1806282-85	Belt, Kevlar
6	806670-1600	Belt, Kevlar
7	103009-03	Weight, Take Up Balancing
7A	806584-08035	Screw Soc, Head Cap (Qty-4)
7B	806606-08	Washer, Lock (Qty-4)
8	108013-55	Guide Bar
9	108011-35	Roll Release Spacer Bar
10	106859-35	Roll Release Bar
11	104308-02	Ramp, Bolt, Receiver, Left
12	104309-02	Ramp, Bolt, Receiver, Left
13	104309-002	Roll Release Extension Bar

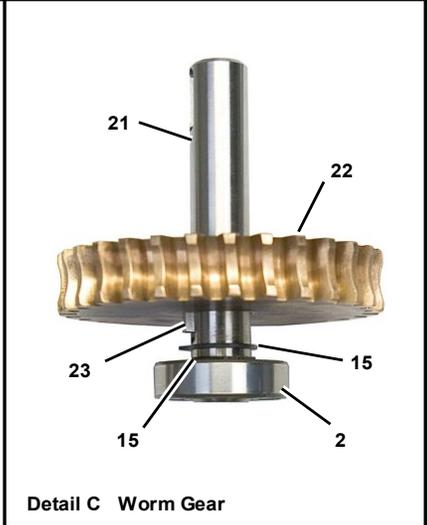
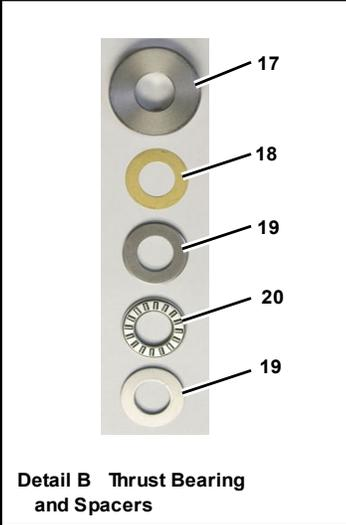
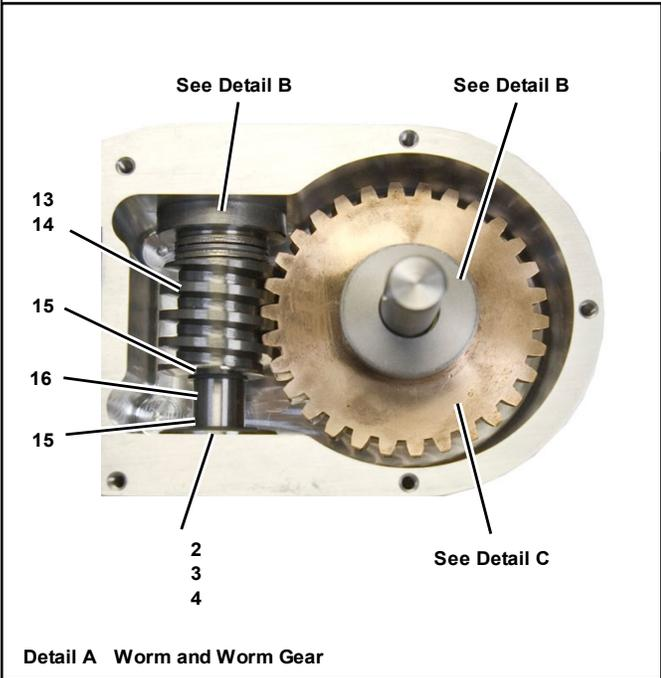
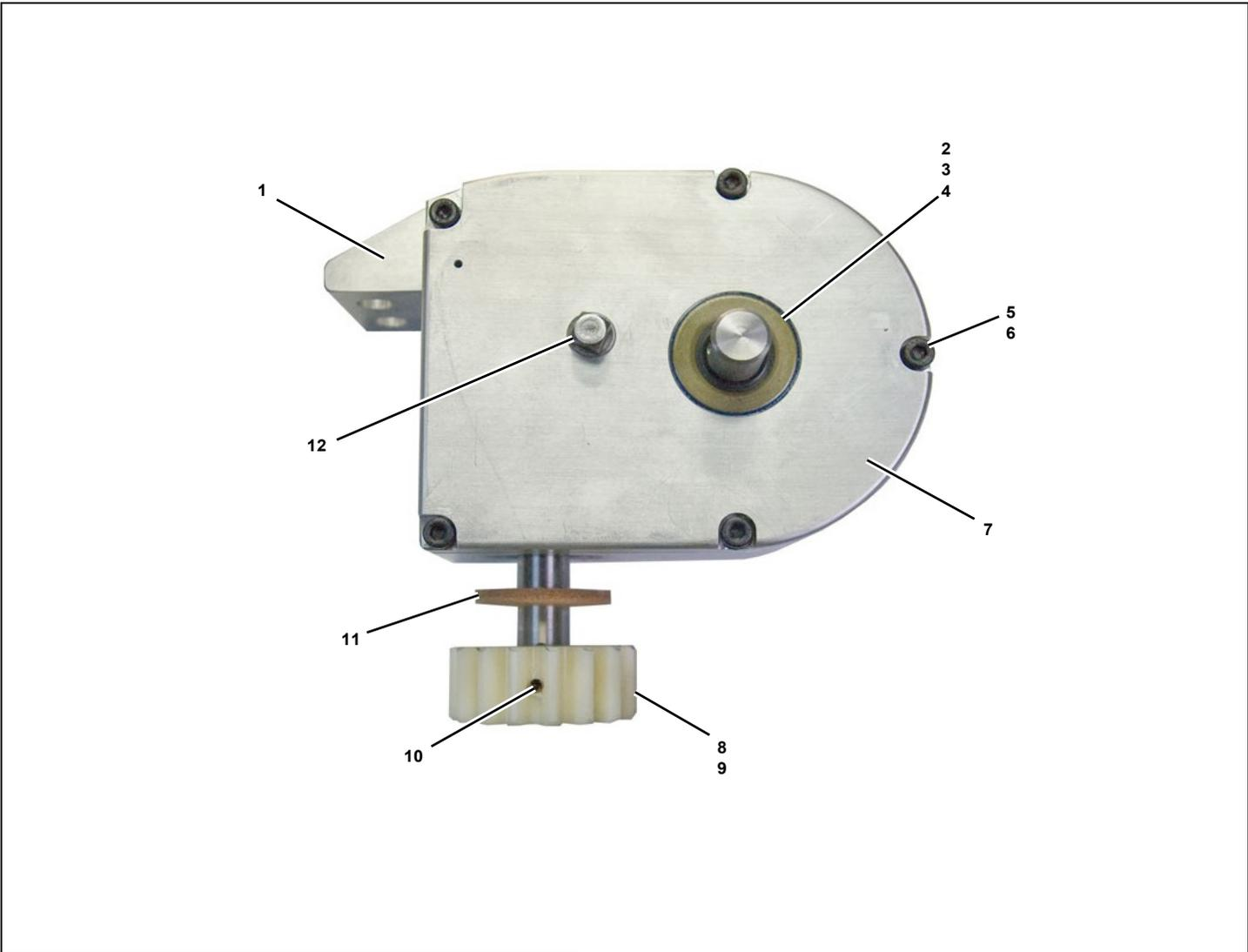

Figure 21. Worm Gear Assembly

Item	Part Number	Description
1A	118993-01	Worm Gear Assembly For Next Higher Assembly, See Figure 3.-3A
1	106839-01	Housing
2	1806274	Ball Bearing (used in 4 places)
3	806419-112	Internal Retaining Ring (used in 3 places)
4	1806255	Seal (used in 3 places)
5	806584-04020	Socket Head Cap Screw, M4 x .7 x 20 mm
6	806597-04	Lock Washer, M4
7	106838	Cover
8	106835	Drive Gear (Nylon)
9	106943	Key, 0.125" x 0.125" x 0.425"
10	806592-0408	Socket Head Set Screw, M4 x .7 x 8 mm
11	1806292	Leather Washer
12	6300	Drain Plug, 1/8 - 27 NPT
13	1806257	Worm, 12 Pitch
14	106943-02	Key, 0.125" x 0.125" x 0.800"
15	806192-050	External Retaining Ring (used in 5 places)
16	106856-01	Worm Shaft
17	106858-01	Spacer
18	806663-04	Shim Washer
19	1806294	Thrust Bearing Washer
20	1806293	Thrust Bearing
21	106855	Worm Gear Shaft (Output)
22	106905	Worm Gear, 30 Tooth x 12 Pitch
23	106943	Key, 0.125" x 0.125" x 0.425"

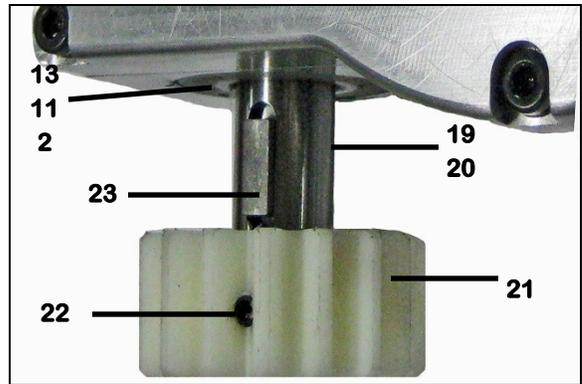
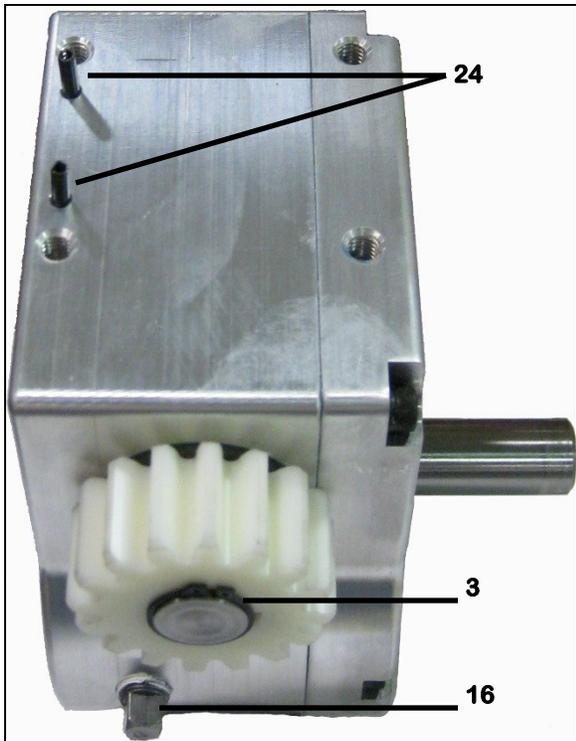
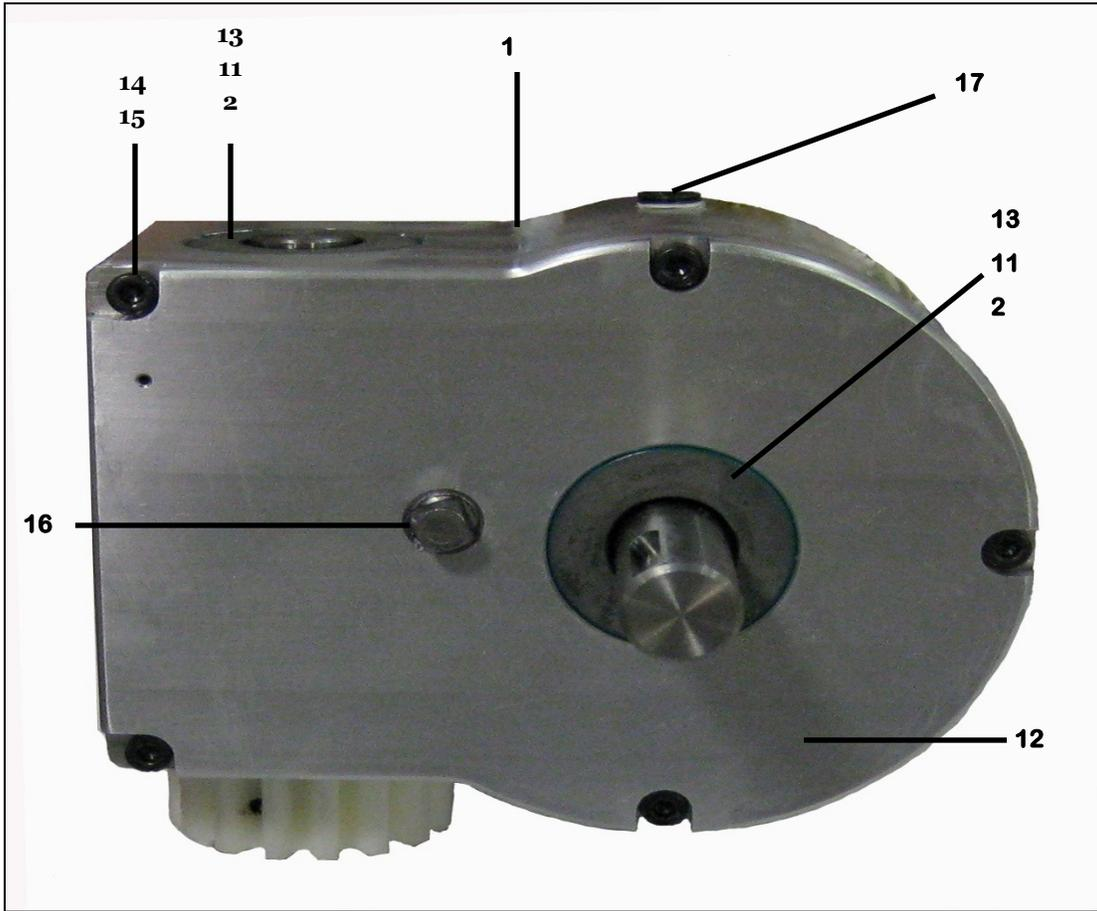

Figure 22 Version 2 Worm Gear Assembly

Item	Part Number	Description
1A	118993-02	Version 2– Worm Box Assembly
1	106839-02	Housing
2	1806340	Bearing, Ball (4 Per Gear Box)
3	006881	Ring, Retaining (5 Per Gear Box)
4	106905-01	Gear, Worm 30T, 10P LH SGL
5	108130-04	Key, SQ 3/16 X .400
6	1806342	Bearing ,Thrust- (2 Per Gear Box)
7	1806341	Washer , Thrust- (4 Per Gear Box)
8	1806348	Shim, 5/8” ID .010 Thick (2 Per Gear Box)
9	106855-01	Shaft Output Worm Box
10	106858-04	Spacer Worm Drive Shaft- (2 Per Gear Box)
11	806419-137	Ring, Internal, Retaining (3 Per Gear Box)
12	106838-01	Cover, Worm Housing
13	1806345	Seal, Oil (3 Per Gear Box)
14	806584-04020	Screw Cap Skt HD M4X0,7X20 (5 Per Gear Box)
15	806597-04	Washer, Split, Lock M4 (5 Per Gear Box)
16	006300	Plug, Pipe 1/8"-27 NPT Square (2 Per Gear Pox)
17	805471-1	Plug Pipe 1/8-27 NPT 3/16
18	1806344	Worm,10P LH SGL-
19	108130-01	Key SQ 3/16 X 1.00
20	106856-02	Shaft, Worm, Dr -
21	106835-02	Gear T/U Dr (NYL)
22	806592-0408	Screw Metric SOC SET CUP PT
23	108130-03	Key,SQ 3/16 X .500
24	007817	Pin, Roll 1/8 X 3/8 Long (2 Per Gear Box)
25	806584-06035	Screw Cap,SKT HD M6X1,0X35 (4 Per Gear Box)
26	806596-06	Washer FLAT 6MM DIN 125 (4 Per Gear Box)
27	806597-06	Washer SPLIT LOCK M6 (4 Per Gear Box)
28	108129	Shield T/U Table-SJ4A/D
29	806587-04008	Screw CAP SKT BTNHD M4X.7X8 (2 Per Gear Box)
30	806385-11	Loctite SM Screw, Thread Lock
31	GM01408	Oil Gear MOBIL SHC 634
18A	106905-02u	Worm Gear, 30 Tooth x 10 Pitch RH SGL (Used on Counter Clockwise Machines, DL)
4A	106905-02	Worm Gear, 30 Tooth x 10 Pitch RH SGL (Used on Counter Clockwise Machines, DL)

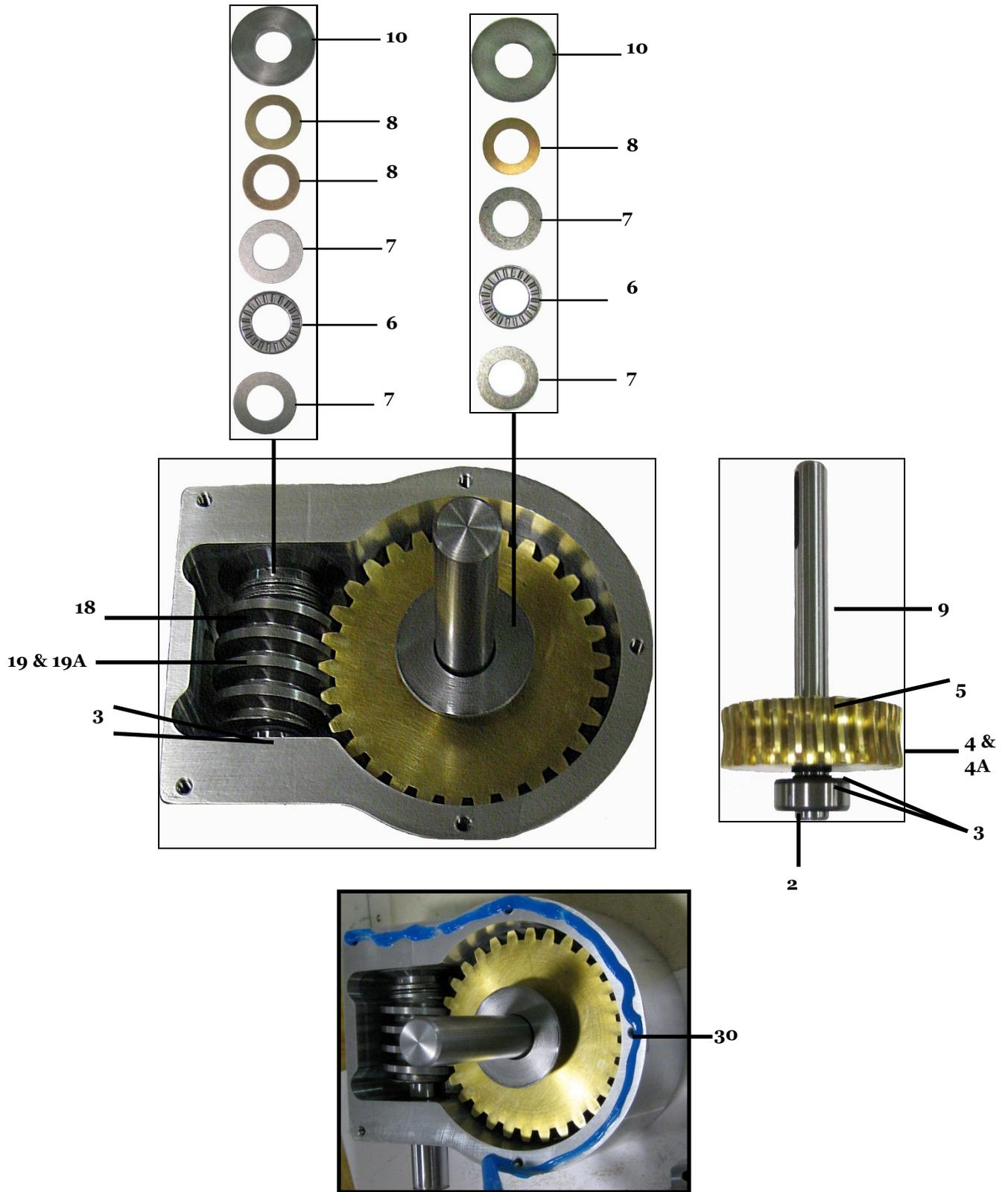

Figure 23. Version 2 Worm Gear Assembly

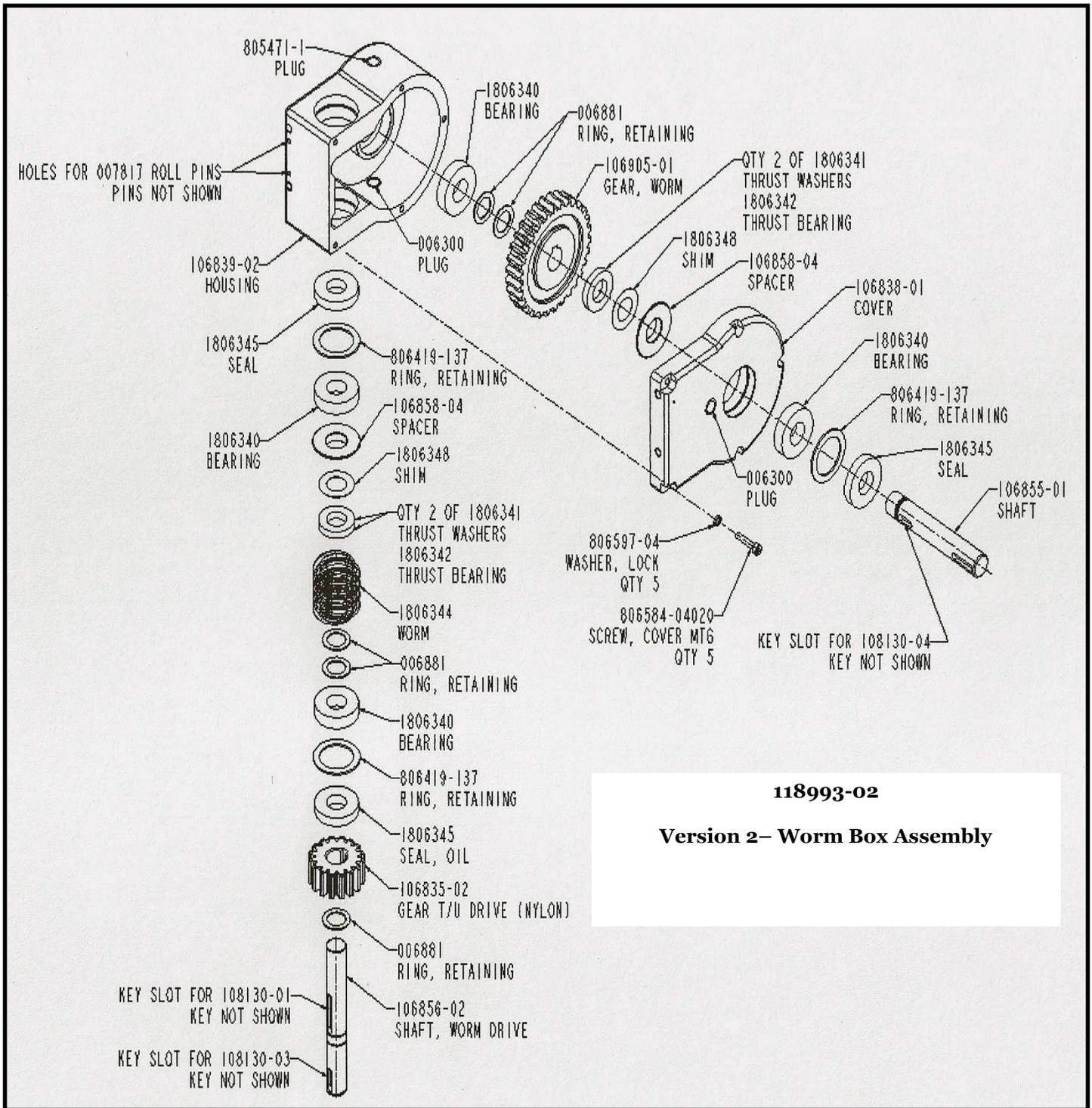

Figure 24. Version 2 Worm Gear Assembly CAD View

WORMBOX CONVERSION KIT ORGANIZATION:

FROM 118993-01 GEAR BOX TO 118993-02 GEAR BOX

119111-[GP][BSH]

KIT, 5/8" SHAFT WORMBOX CONVERSION:

INDIVIDUAL KIT CONTENTS:

QUAN.	PART NUMBER	DESCRIPTION
1	118993-02	GEAR WORM ASSY - SJ4A/DELTA
1	119035-3 [GP]	SHAFT, T/U DR ASSY-DELTA T/U
1	106827-1[GP]	BAR, SPRING T/U
4	806584-06040	SCREW CAP SKT HD
4	806596-06	WASHER METRIC PLAIN
4	806597-06	WASHER METRIC SPLIT LOCK
EACH KIT WILL CONTAIN 1 BUSHING, EITHER 1008,1108,1619,OR 2012		
IF DRIVER PULLEY BUSHING [BSH] IS 1008, ADD:		
1	806667	BUSHING, T'BELT U'ROYAL TL1008
IF DRIVER PULLEY BUSHING [BSH] IS 1108, ADD:		
1	806667-01	BUSHING, T'BELT U'ROYAL TL1108
IF DRIVER PULLEY BUSHING [BSH] IS 1610, ADD:		
1	806669	BUSHING, T'BELT U'ROYAL TL1610
IF DRIVER PULLEY BUSHING [BSH] IS 2012, ADD:		
1	1806186-159	BUSHING, T'BELT U'ROYAL TL2012

NEEDED FOR -TAB SERIES: (IN THE FORM OF -[GP][BSH])

-00 1108 KIT, WRMBOX CONV GP 0 2+3 END FLC

-00 1108 KIT, WRMBOX CONV GP 0 2+3 END FLC

-00 2012 KIT, WRMBOX CONY GP 0 JERSEY

-01 1108 KIT, WRMBOX CONV GP 1 2+3 END FLC

-01 2012 KIT, WRMBOX CONY GP 1 JERSEY

-02 1108 KIT, WRMBOX CONV GP 2 2+3 END FLC

-02 1610 KIT, WRMBOX CONV GP 2 JERSEY

-03 1008 KIT, WRMBOX CONY GP 3 3 END FLC

-03 1108 KIT, WRMBOX CONV GP 3 2 END FLC + FINE CT JERSEY

-03 1610 KIT, WRMBOX CONV GP 3 COARSE JERSEY

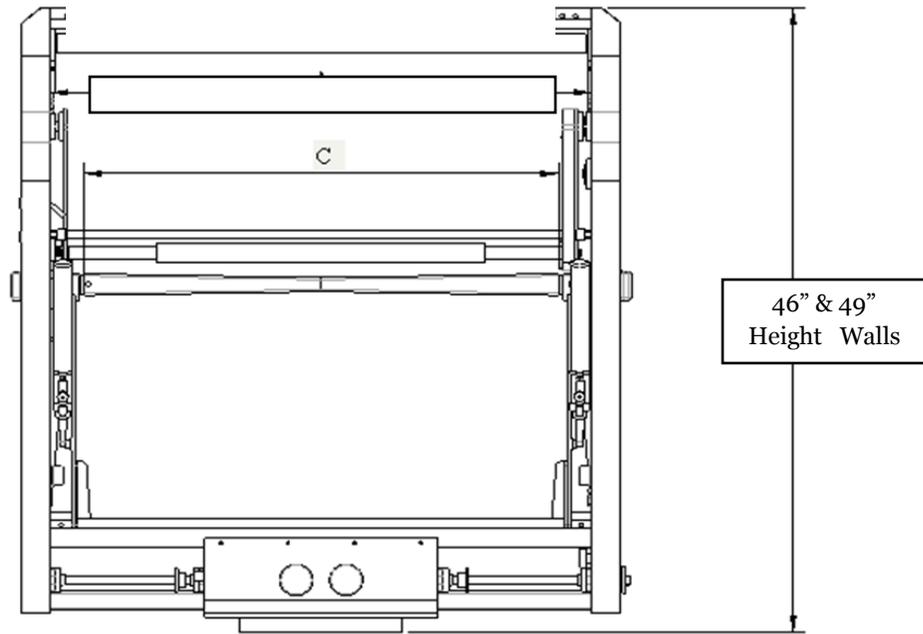

**Center Roll SJ4A/DI3, DI2, SJ3A/DI3, DI2 Take Up
8000-EE01-18-24-34SN05**

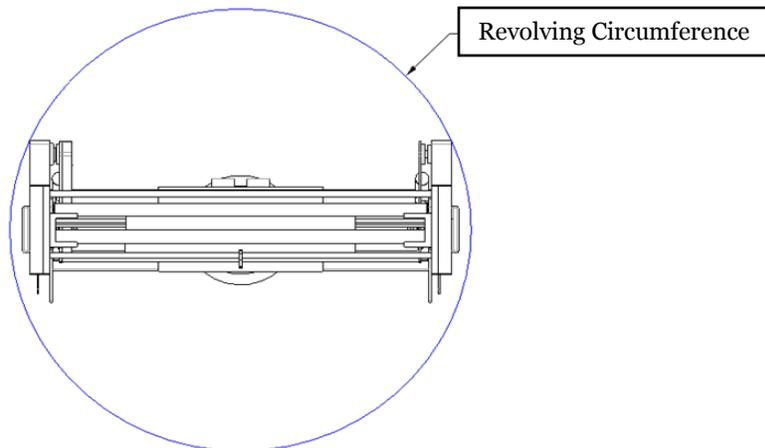

CENTER ROLL
TAKE-UP GROUPS, 0,1,2,3,5

Left Side Wall 46"- 49" Center Roll Take Up

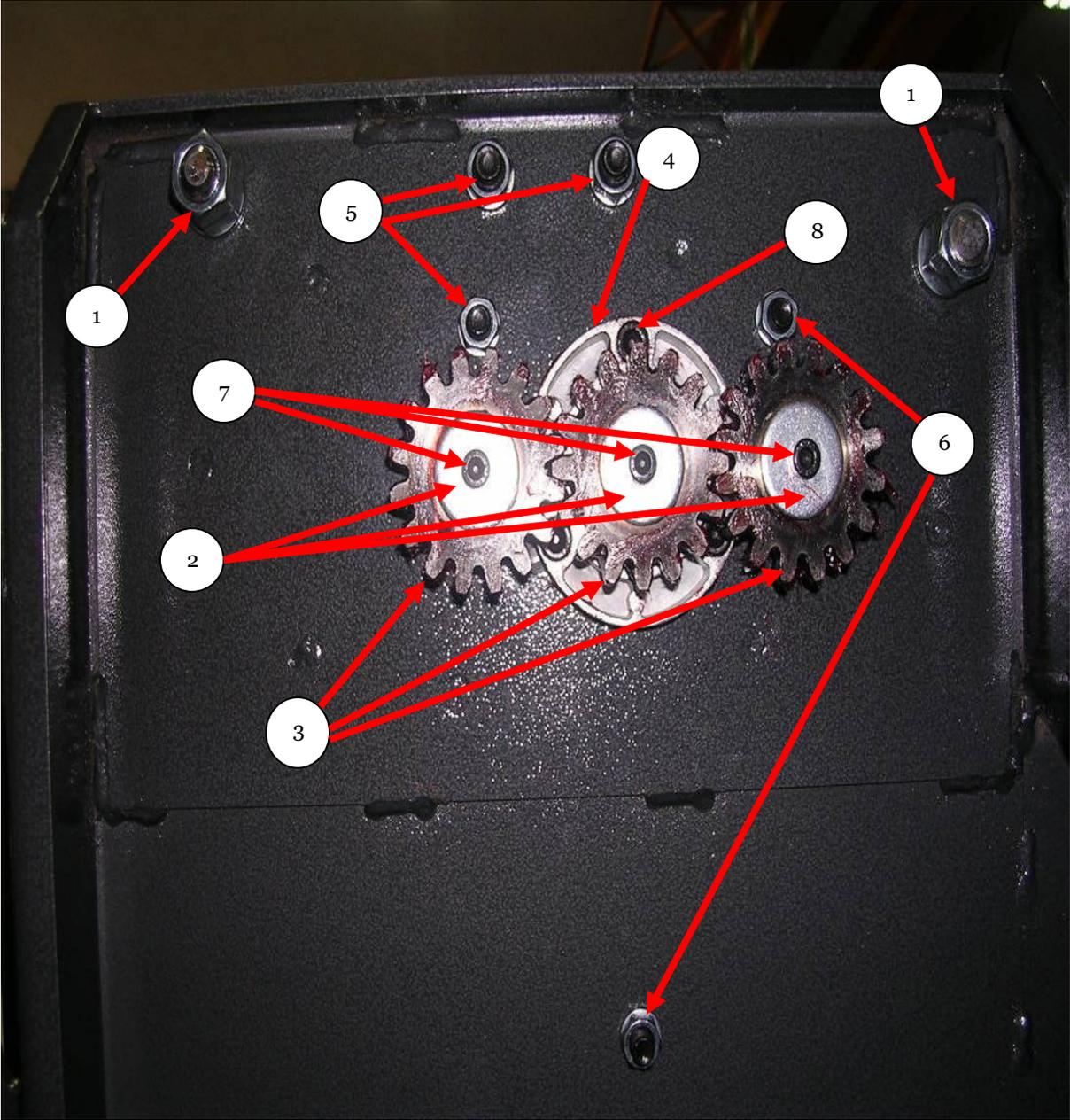

Item	Part Number	Description
1	9MN00-M12	Locking Nut
2	9MW00-W5.2X25	Fender Washer
3	ER34-8243-C0-001	Sprocket
4	ER34-8121-C0-001	Bearing Base Housing
5	9MN00-M10	Locking Nut
6	9MN00-M8	Locking Nut
7	9SC01-M6X15	Screw Cap,SKT HD M6X1,0X15
8	9SC01-M8X25	Screw Cap,SKT HD M8X1,0X25

Left Side Wall 46"- 49" Center Roll Take Up

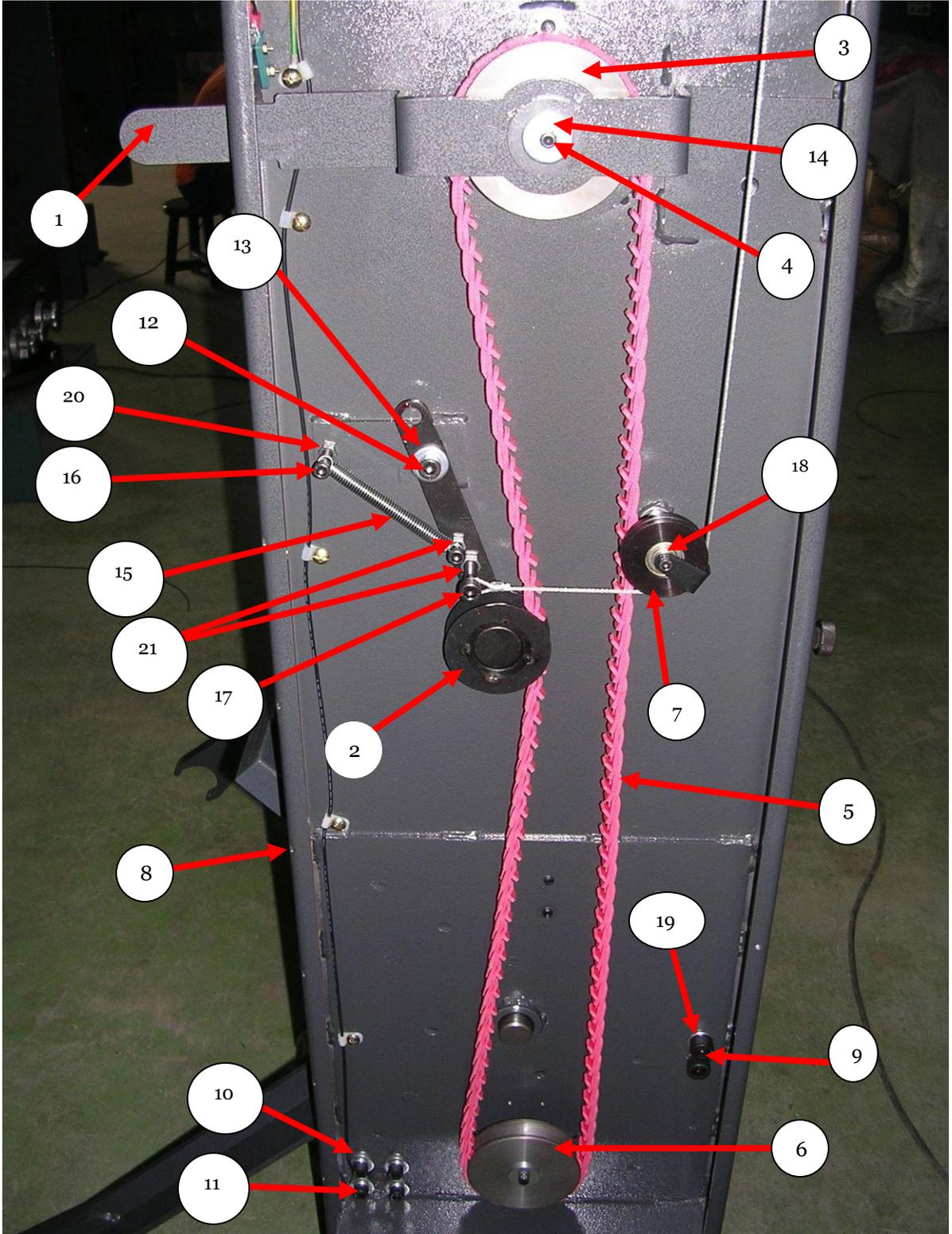

Item	Part Number	Description
1	ER34-8281-CO-002	Switch Bar
2	ES24-8202-D0-001	Adjusting Idler Wheel
3	ER34-8272-C0-001	Idler
4	9MW00-W5.2X25	Flat Washer, M5
5	806505	Power Twist V-Belt
6	ER34-8306-C0-001	Idler
7	ROL-A34	Guide Wheel
8	ER24—8201-D0-008	49" Left Take Up Wall
	ER34—8201-D0-003	49" Left Take Up Wall
9	9SC01-M10X35	Socket Head Cap Screw
10	9MW00-W6.25X25	Flat Washer, M6
11	9SC01-M8X25	Screw Cap,SKT HD M8X1,0X25
12	9SC01-M8X20	Screw Cap,SKT HD M8X1,0X20
13	9MW00-W8	Flat Washer, M6
14	9SC01-M5X16	Socket Head Cap Screw
15	9SC01-0.9X9X50	Tension Spring
16	9SC01-M6X10	Screw Cap,SKT HD M6X1,0X10
17	9SC01-M8X20	Screw Cap,SKT HD M8X1,0X20
18	9SC01-M5X20	Screw Cap,SKT HD M5X1,0X20
19	9MW00-W10	Flat Washer, M10
20	9MN00-M6	Lock Nut
21	9MN00-M8	Lock Nut

Left Side Wall 46"- 49" Center Roll Take Up

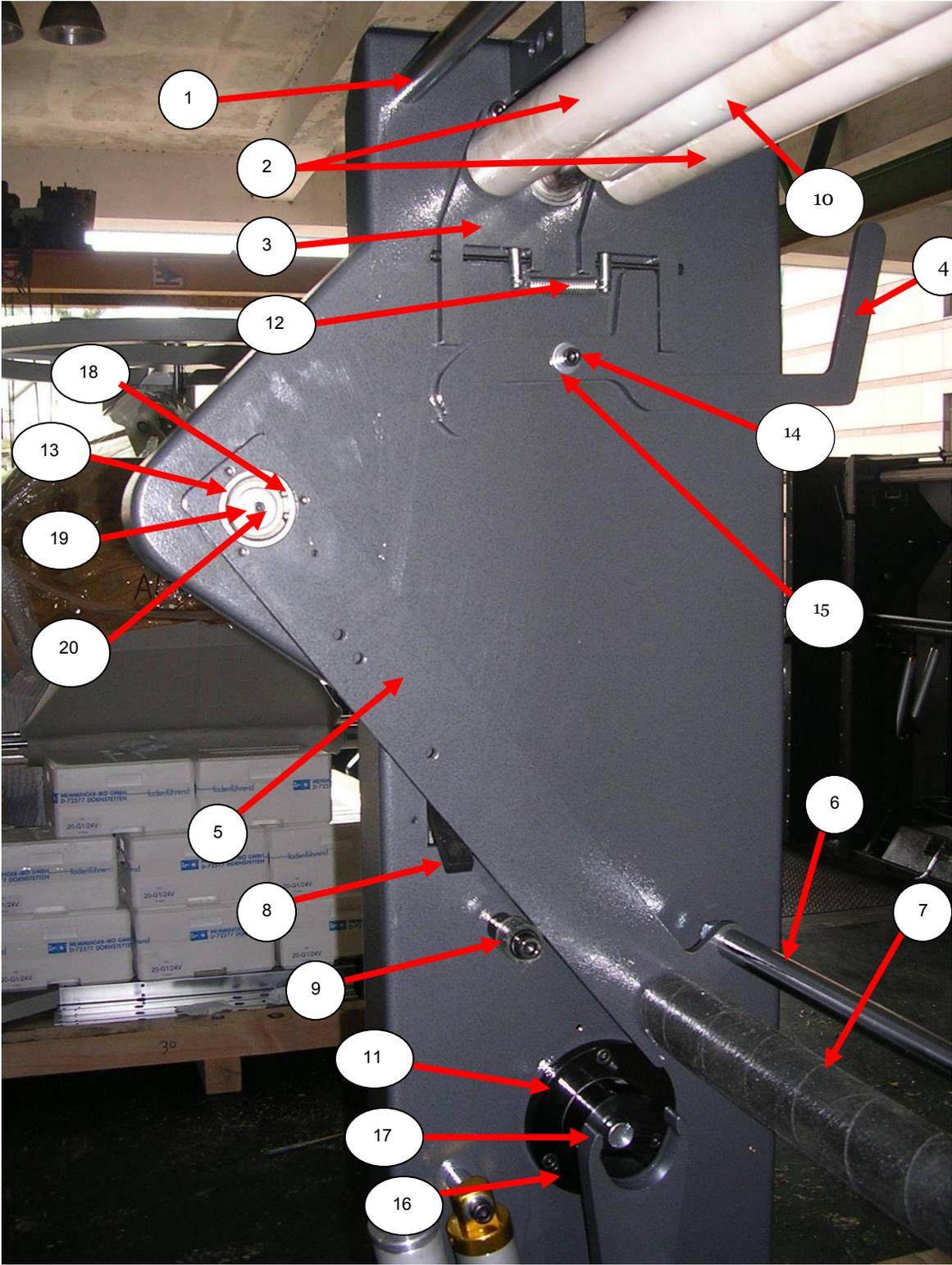

Item	Part Number	Description
1	ER24-8502-C0-001	Support Bar
1	ER34-8502-C0-001	Support Bar 34"X46" SIDEWALL
2	ER24-8504-C0-001	Top Idler Roller Assembly Front and Back (2)
2	ER34-8504-C0-001	Top Idler Roller Assembly Front and Back (2) 34"X46" SIDEWALL
2	ER24-8504-C0-002	Top Idler Roller Assembly Front and Back (2) 24"X49" SIDEWALL
3	ER34-8131-C0-005	Clutch Base
4	ER34-8135-C0-001	Clutch Handle Actuator
5	ER34-8403-D0-001	Left Arm of Roller Assembly
6	ER24-8401-C0.001	Swing Arm Support Bar
7	ER24-8402-C0-001	Friction Roller
8	ES24-8144-D0-004	Reaction Bar Stop
9	ER34-8102-C0-001	Stud, Arm Stop
10	ER24-8503-C0-001	Top Drive Roller Assembly
10	ER18-8503-C0-001	Top Drive Roller Assembly 18"X49" SIDEWALL
10	ER34-8503-C0-001	Top Drive Roller Assembly 34"X46" SIDEWALL
11	ER34-8271-C0-001	Cloth Roller Drive Base
12	9SP00-0.9X9X58	Tension Spring
13	ER34-8145-CO-001	Bearing
14	9SC02-M8X25	Screw Cap,SKT HD M8X1,0X25
15	9MW00-W10	Flat Washer, M10
16	9SC01-M8X30	Screw Cap,SKT HD M8X1,0X30
17	ER34-8274-CO-002	Transmission Shaft
18	9MROB-0040	Retaining Ring
19	9MW00-W5.2X25	Flat Washer, M5
20	9SC01-M5X14	Screw Cap,SKT HD M5X1,0X14

Left Side Wall 46"- 49" Center Roll Take Up

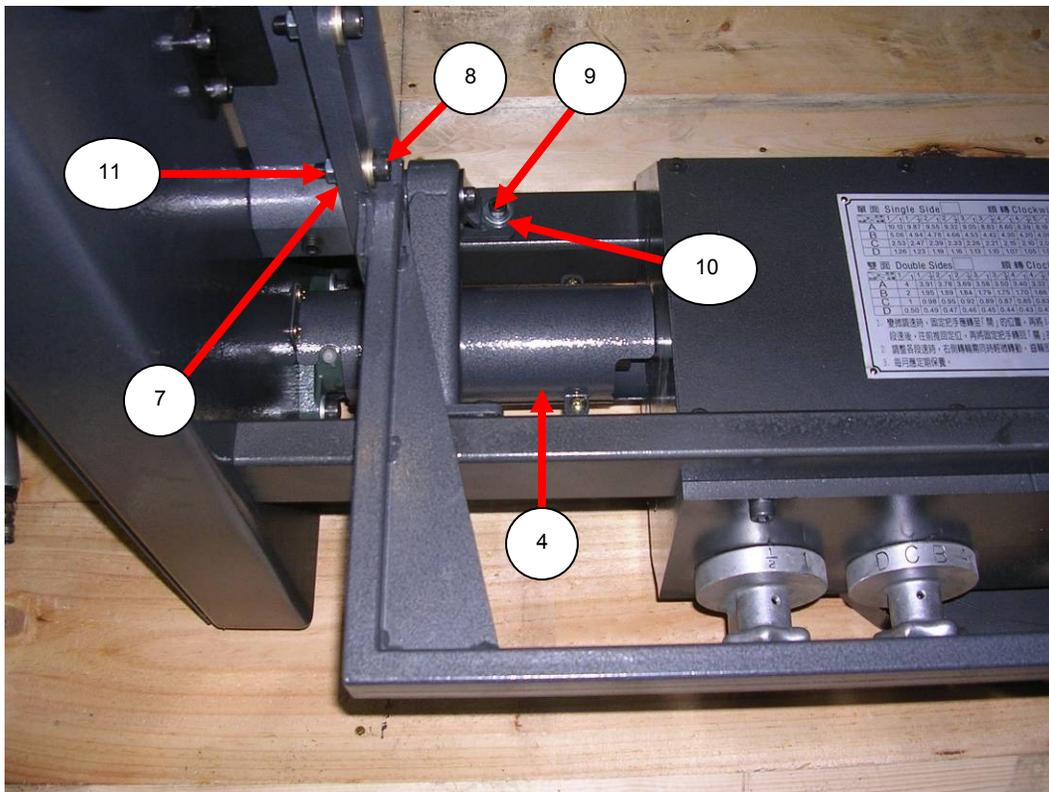
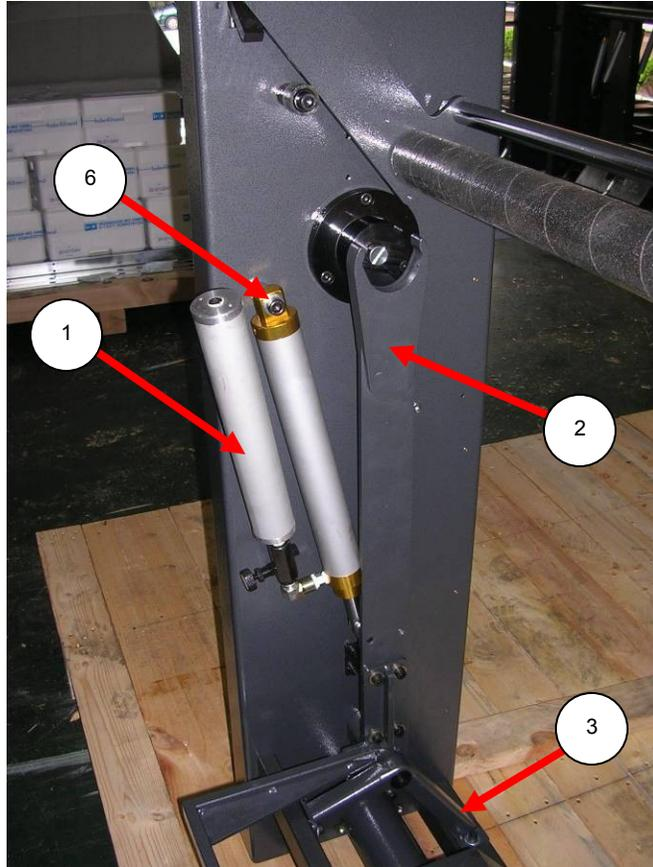

Item	Part Number	Description
1	9H035-SD40	Hydraulic Cylinder
2	ER24-8501-D0-001	Roll Doffing Arm (Left Side) 18X46" SIDEWALL
3	ER36-8501-D0-006	Roll Doffing Arm (Left Side) 34X46" SIDEWALL
3	ER24-8501-D0-001	Roll Doffing Arm (Left Side) 24X49" SIDEWALL
3	ER24-8309-C0-002	Take-Up Base Support Bar
4	ER34-8309-C0-001	Dust Cover
5	ER24-8508-C0-003	Link Bar 24X49" SIDEWALL
5	ER18-8508-C0-002	Link Bar 18X46" SIDE WALL
5	ER34-8508-C0-003	Link Bar 34X46" SIDEWALL
6	9SC01-M8X60	Screw Cap, SKT HD M8X1,0X60
7	9MW00-W8	Flat Washer, M8
8	9SC01-M8X25	Screw Cap, SKT HD M8X1,0X25
9	9SC01-M8X16	Screw Cap, SKT HD M8X1,0X16
10	9MW00-W8	Flat Washer, M8
11	9MN00-M8	Lock Nut

Right Side Wall 46"- 49" Center Roll Take Up

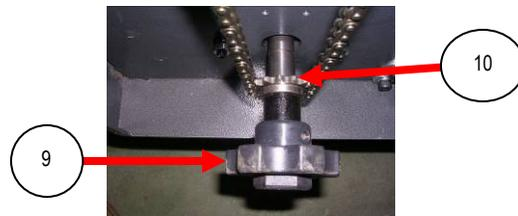
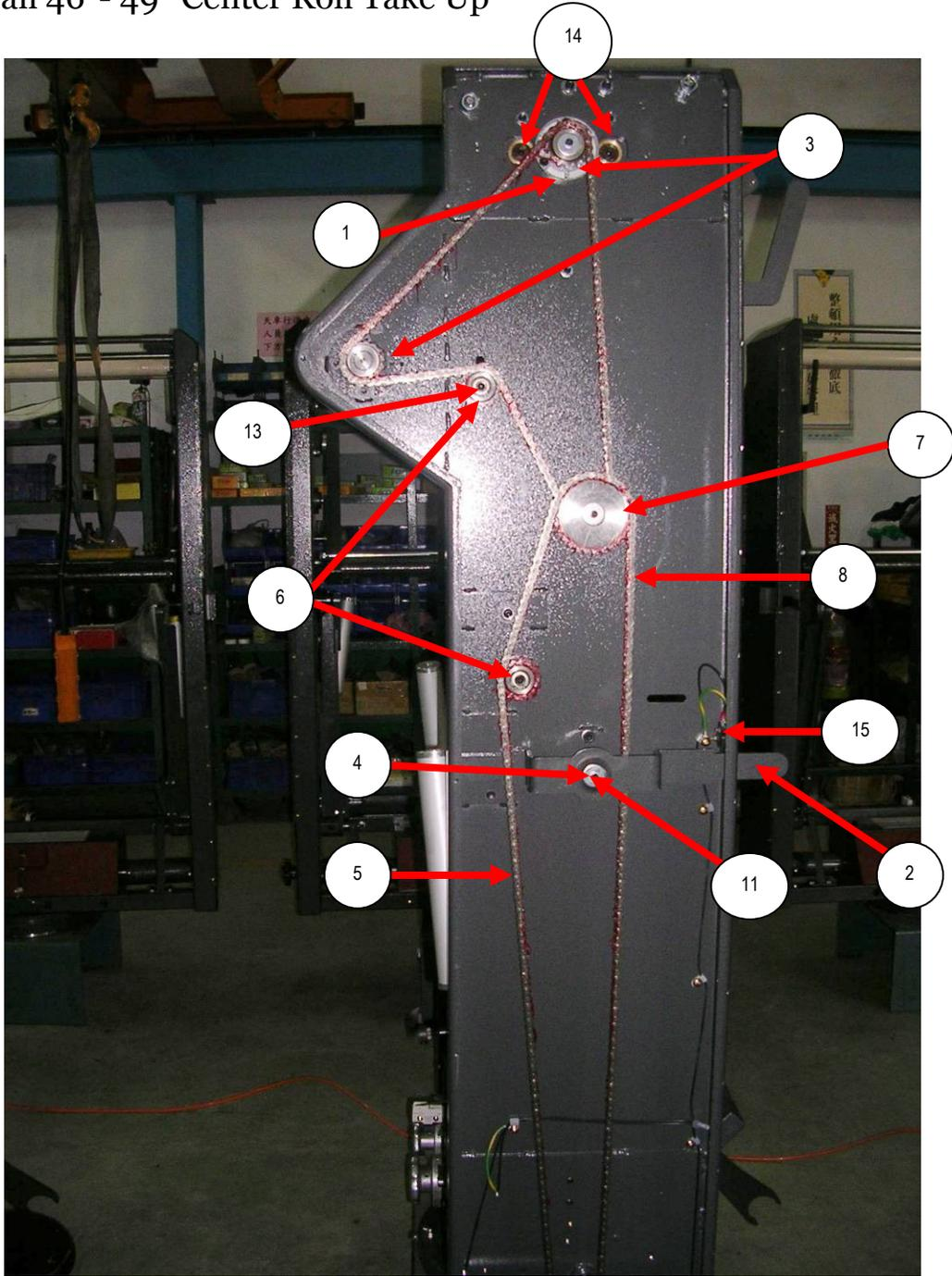

Item	Part Number	Description
1	ER34-8121-C0-001	Bearing Base
2	ER35-8281-C0-002	Roll Release Lever (Switch Bar)
3	ER34-8143-C0-002	Sprockets (15T)
4	9MW00-W5.2X25	Flat Washer, M5
5	ER34-8123-D0-002	Chain
6	ER34-8166-C0-001	Sprocket (22T)
7	ER34-8144-C0-002	Sprocket (28T Behind & 48T Front)
8	ER34-8167-D0-002	Chain
9	ER34-8305-C0-001	Adjusting Knob
10	ER34-8146-C0-001	Sprockets (14T)
11	9SC01-M5X16	Screw Cap,SKT HD M5X1,0X16
12	9SC01-M8X20	Screw Cap,SKT HD M8X1,0X20
13	9MW00-W8	Flat Washer, M8
14	108285	Oilite Bushing
15	775519	Lever Engagement Microswitch Switch

Right Side Wall 46"- 49" Center Roll Take Up

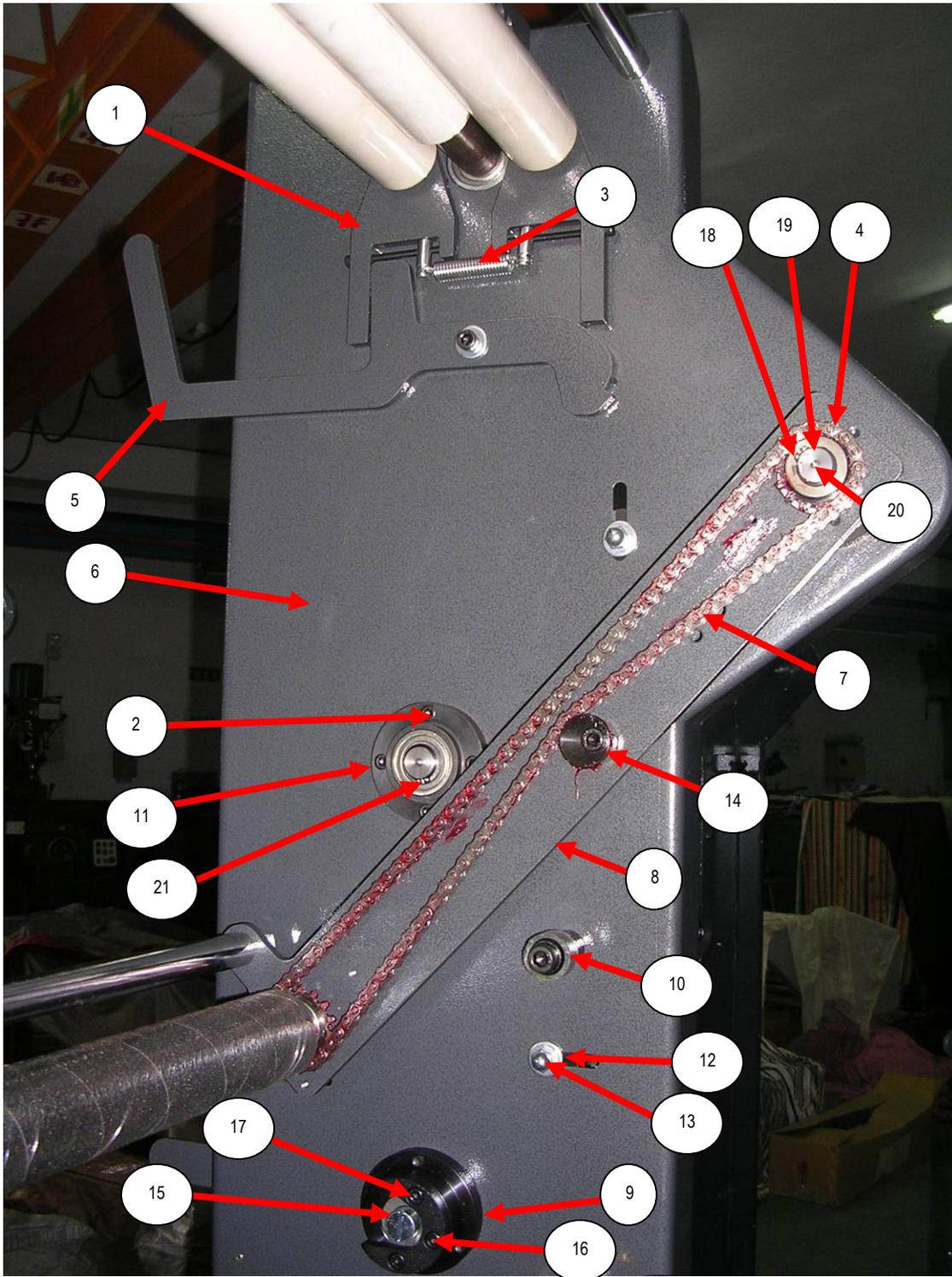

Item	Part Number	Description
1	ER34-8131-C0-005	Clutch Base
2	9SC01-M5X20	Screw Cap,SKT HD M5X1,0X20
3	9SP00-0.9X9X58	Tension Spring
4	ER34-8141-C0-001	Bearing Unit
5	ER34-8141-C0-001	Roller Clutch Handle
6	ER34-8101-D0-008	49" Right Side Wall
7	ER34-8446-D0-001	Drive Chain
8	ER34-8403-D0-001	49" Friction Drive Roller Swing Arm
9	ER34-8173-C0-003	Cloth Roller Base
10	ER34-8102-C0-001	Swing Arm Stop
11	ER34-8141-C0-001	Bearing Housing (Chain Drive)
12	9MW00-W8.2X25	Flat Washer, M8
13	9SC01-M8X20	Screw Cap,SKT HD M8X1,0X20
14	ER34-8445-C0-001	Chain Tensioner
15	ER34-8173-C0-004	Cloth Roller Receiver Base
16	9C01-M8X25	Screw Cap,SKT HD M8X1,0X25
17	9C01-M6X30	Screw Cap,SKT HD M8X1,0X30
18	9MROB-0040	Retaining Ring
19	9MW00-W5.2X25	Flat Washer, M5
20	9SC01-M5X14	Screw Cap,SKT HD M5X1,0X14
21	9MROB-0020	Retaining Ring

Right Side Wall 46"- 49" Center Roll Take Up

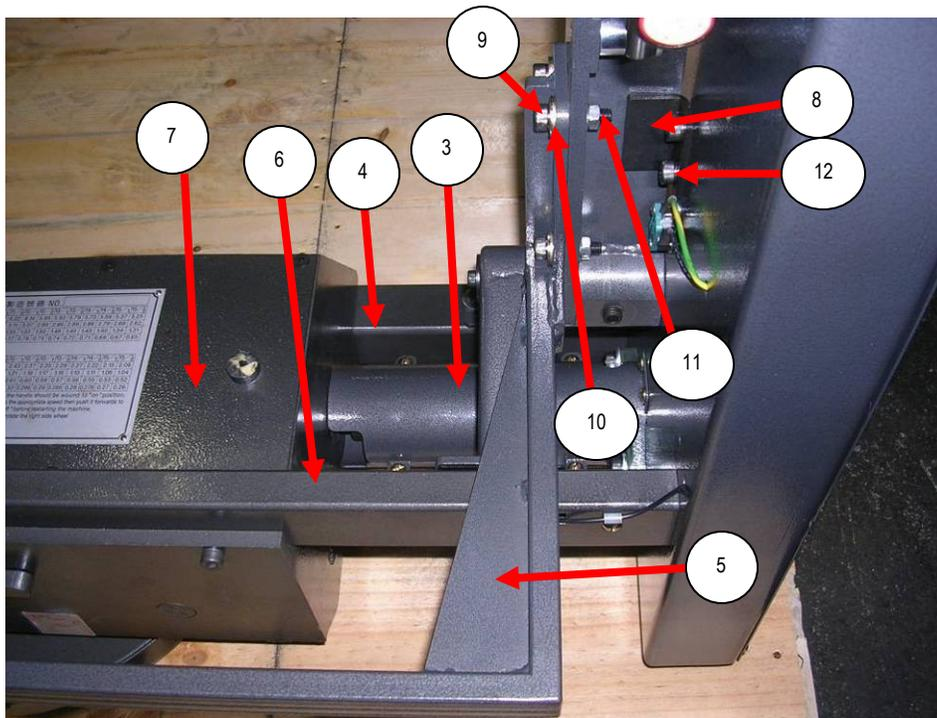
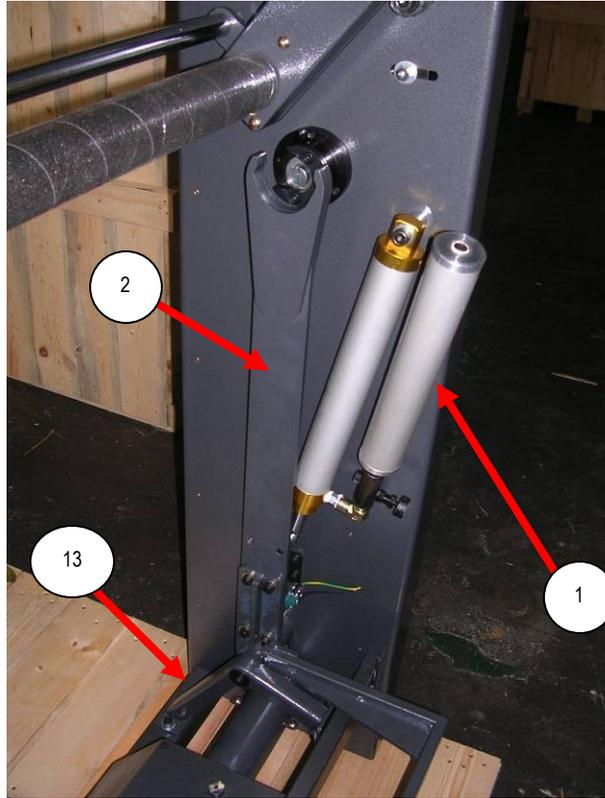

Item	Part Number	Description
1	9H035-SD40	Hydraulic Cylinder
2	ER34-8501-D0-004	Take up Support Crutch
3	ER34-8501-D0-001	Take up Support Crutch
3	ER34-8501-D0-006	Take up Support Crutch 34X46" SIDEWALL
3	ER34-8309-C0-001	Dust Cover
4	ER24-8307-C0-002	Main Frame Bar 24X49" SIDEWALL
4	ER18-8307-C0-001	Main Frame Bar 50X50X4
4	ER34-8307-C0-004	Main Frame Bar 50X50X4
5	ER24-8508-C0-003	Link Bar 24X49" SIDEWALL
5	ER18-8508-C0-003	Link Bar 24X49" SIDEWALL
6	ER34-8302-C0-002	Main Frame Bar 24X49" SIDEWALL
6	ER18-8302-C0-001	Main Frame Bar 34X46" SIDEWALL
6	ER34-8302-C0-003	Main Frame Bar 34X46 "SIDEWALL
7	ER24-8301-C0-001	GEAR BOX 34X46" SIDEWALL, 24X49" SIDEWALL
7	ER34-8301-C0-002	GEAR BOX 18X49" SIDEWALL
8	ER34-8106-C0-001	Locating Block
9	9SC01-M8X25	Screw Cap,SKT HD M8X1,0X25
10	9MW00-W8	Flat Washer, M8
11	9MN00-M8	Locking Nut
12	9SC01-M8X16	Screw Cap,SKT HD M8X1,0X16
13	ER24-8309-C0-001	Support BASE 24X49" SIDEWALL
13	ER24-8309-C0-002	Support BASE 18X49" SIDEWALL

Right Side Wall 46"- 49" Center Roll Take Up

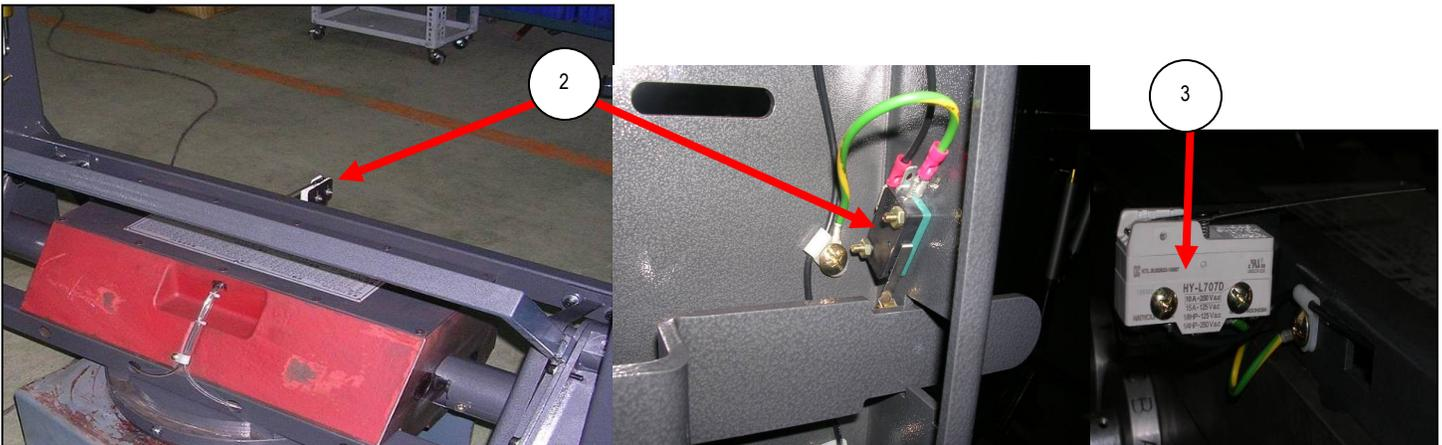
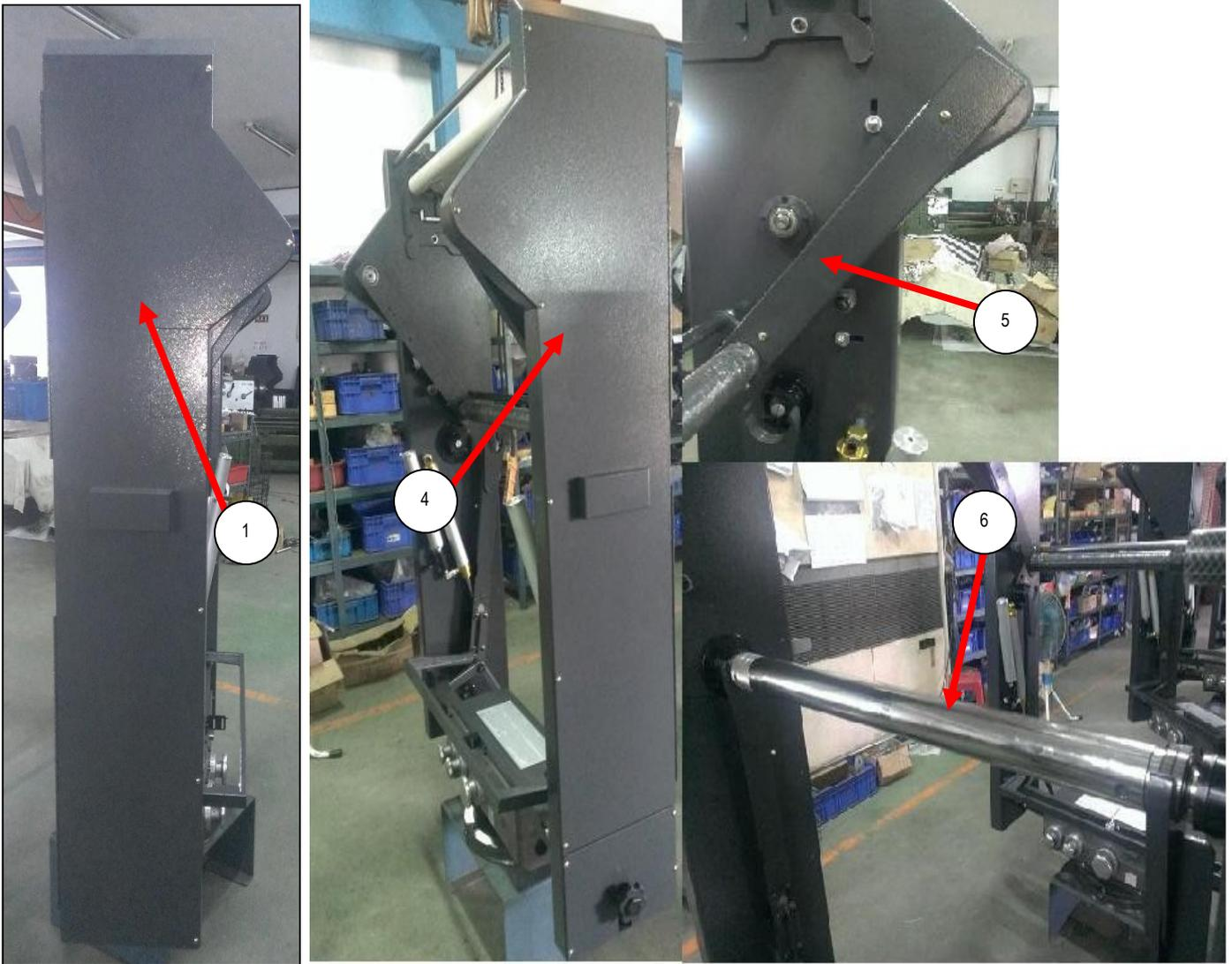

Titan 3590_02_, Revision F

Item	Part Number	Description
1	ER34-8105-D0-007	Right Sidewall Access Panel 18X49" SIDEWALL
1	ER34-8103-D0-003	Right Sidewall Access Panel 34X46" SIDEWALL
2	EL03-1578-VPL	Microswitch
3	775519	Limit Switch
4	ER34-8105-D0-008	46" Right Sidewall Cover
5	ER34-8105-D0-001	45" Chain Drive Cover
6	ER34-8501-D0-005	Cloth Roller Rod

Mechanical Gear Box (Left Side)

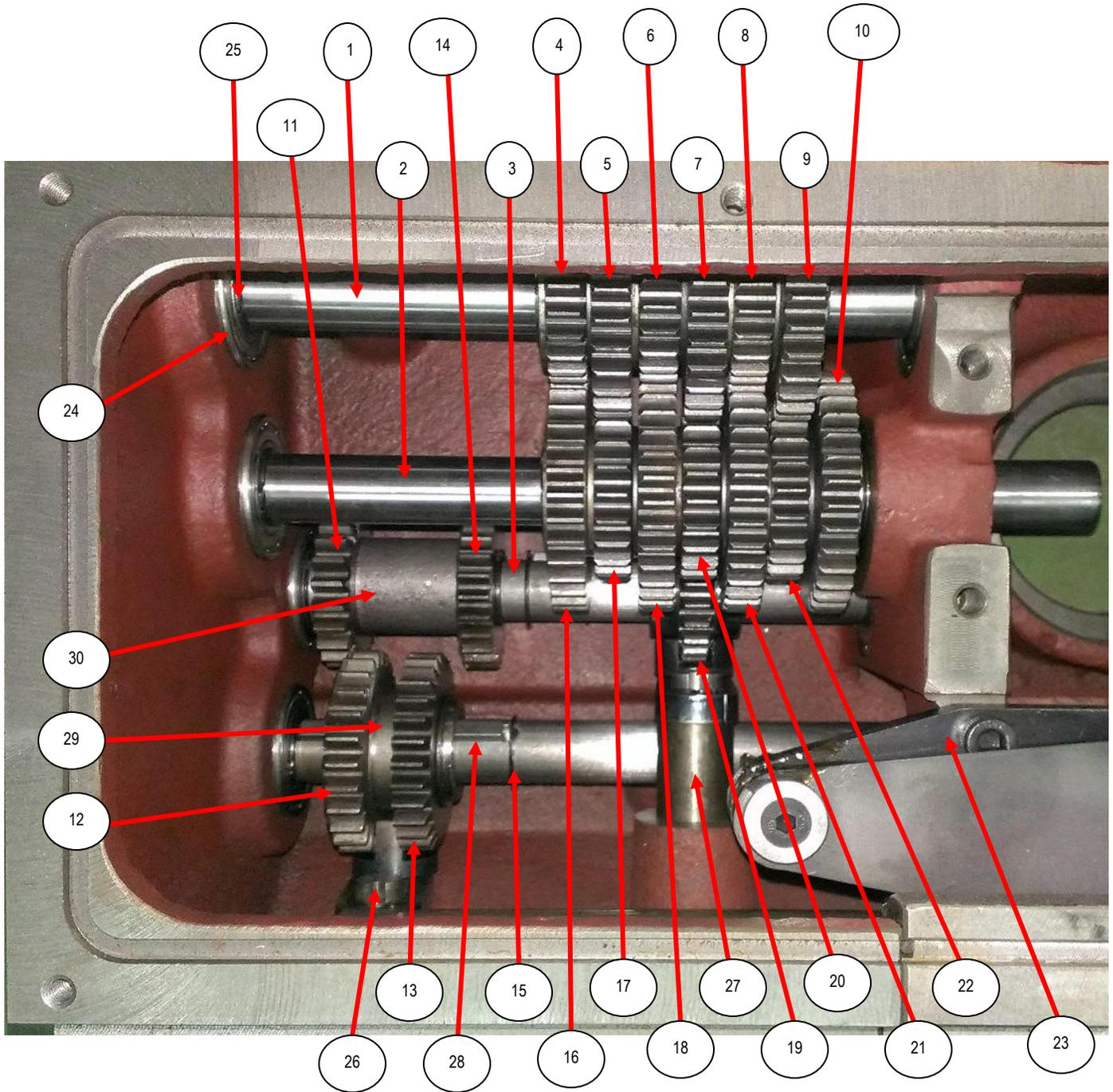

Item	Part Number	Description
1	8000-20X200MM	Gear Drive Shaft
2	8000-20X290MM	Gear Drive Shaft
3	8000-20X200MM	Gear Drive Shaft
4	8000-Z22-M2X22T	Gear
5	8000-Z28-M2X28T	Gear
6	8000-Z22-M2X22T	Gear
7	8000-Z28-M2X28T	Gear
8	8000-Z22-M2X22T	Gear
9	8000-Z28-M2X28T	Gear
10	8000-Z33-M2X33T	Gear
11	8000-Z21-M2X21T	Gear
12	8000-Z26-M2X26T	Gear
13	8000-Z29-M2.25X29T	Gear
14	8000-Z24-M2.25X24T	Gear
15	8000-20X560MM	Gear Drive Shaft
16	8000-Z33-M2X33T	Gear
17	8000-Z21-M2X21T	Gear
18	8000-Z33-M2X33T	Gear
19	8000-Z22-M2X22T	Gear
20	8000-Z21-M2X21T	Gear
21	8000-Z33-M2X33T	Gear
22	8000-Z21-M2X21T	Gear
23	8000-Z60-001	Gear Shifting Lever
24	9MB60-0020	Bearing
25	9MROA-0020	Retaining Ring
26	8000-Z64-001	Eccentric
27	8000-Z64-002	Eccentric
28	9KE00-7X7X30	Key
29	8000-Z63-001	Spacer Collar
30	8000-Z63-002	Spacer Collar

Mechanical Gear Box (Right Side)

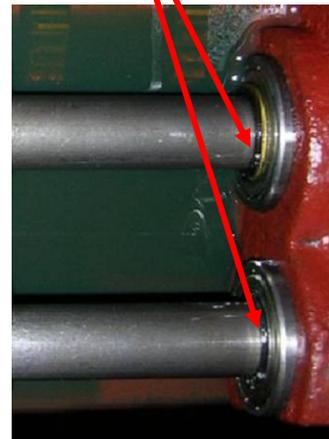
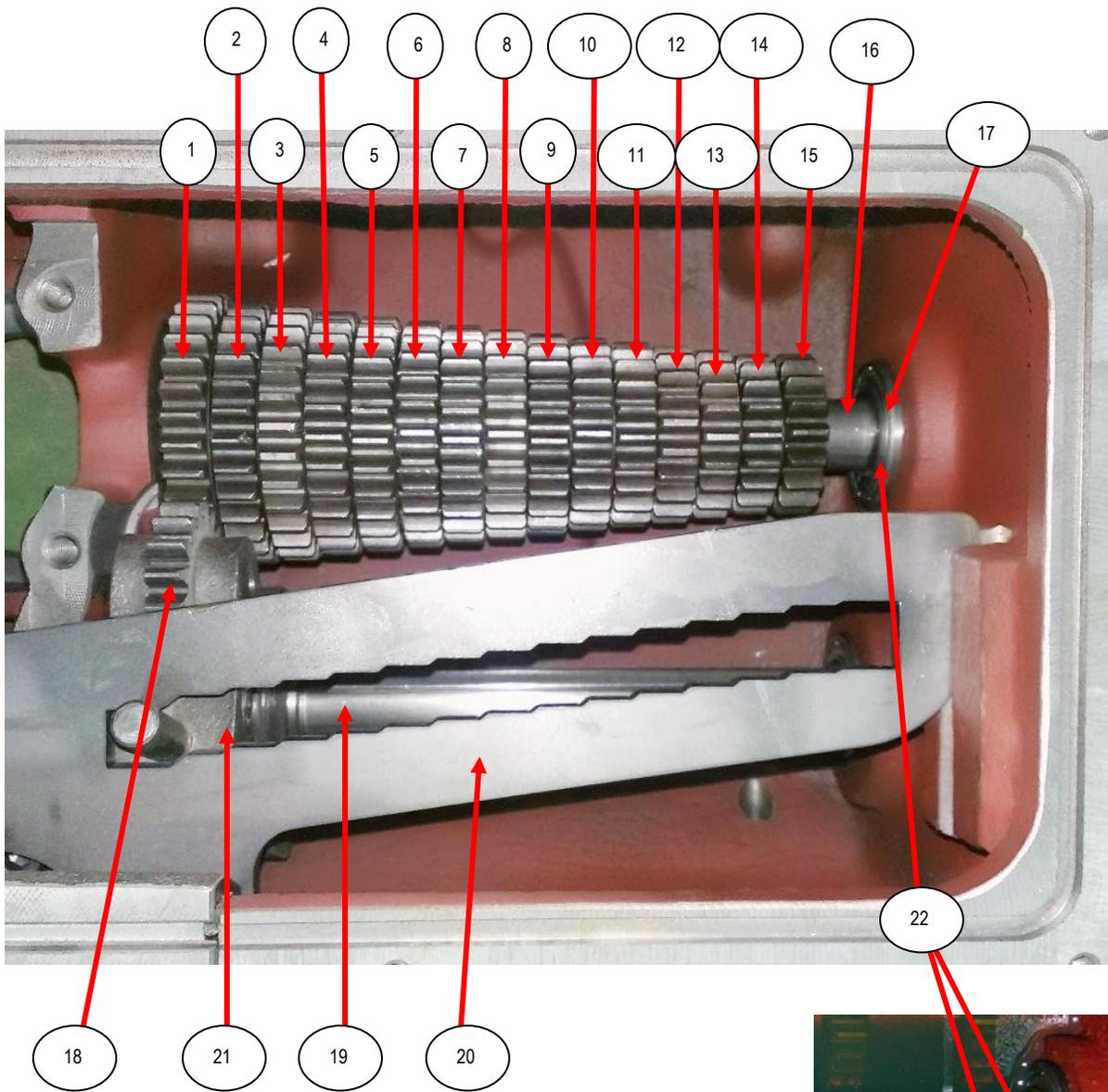

Item	Part Number	Description
1	8000-Z32-M2X32T	Gear
2	8000-Z30-M2X30T	Gear
3	8000-Z29-M2X29T	Gear
4	8000-Z28-M2X28T	Gear
5	8000-Z27-M2X27T	Gear
6	8000-Z26-M2X26T	Gear
7	8000-Z25-M2X25T	Gear
8	8000-Z24-M2X24T	Gear
9	8000-Z23-M2X23T	Gear
10	8000-Z22-M2X22T	Gear
11	8000-Z21-M2X21T	Gear
12	8000-Z20-M2X20T	Gear
13	8000-Z19-M2X19T	Gear
14	8000-Z18-M2X18T	Gear
15	8000-Z17-M2X17T	Gear
16	8000-20X260MM	Gear Drive Shaft
17	9MB60-0020	Bearing
18	8000-Z17-M2X17T	Gear
19	8000-20X560MM	Gear Drive Shaft
20	8000-Z60-002	Roller Speed Progression Plate
21	8000-Z61-001	Transmission Shifter Pin Holder
22	8000-Z62-001	Oil Seal

Take Up Electrical Contactor Assembly

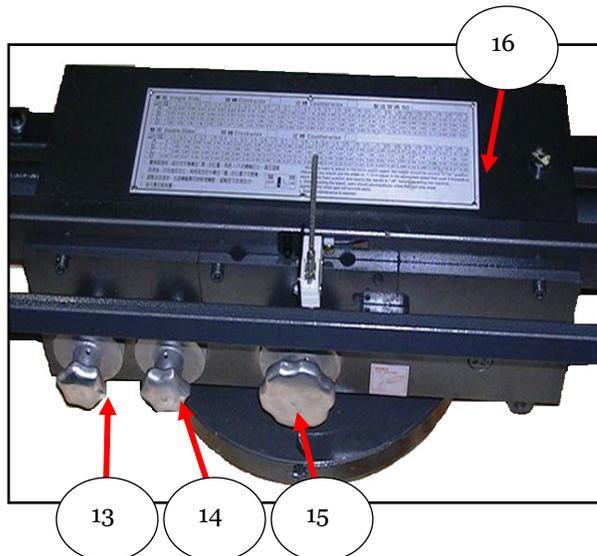
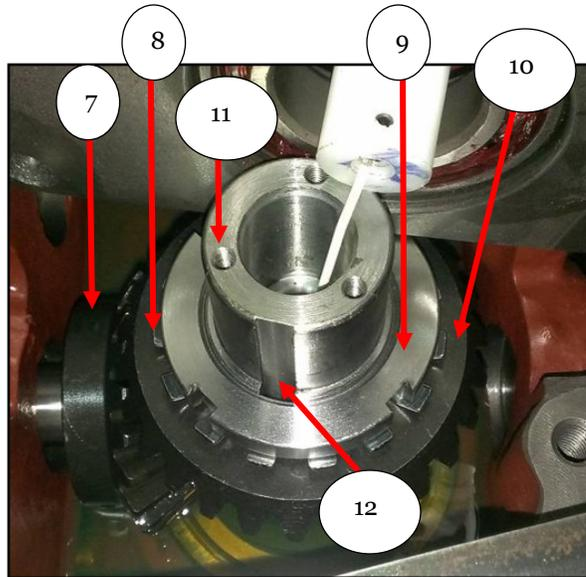
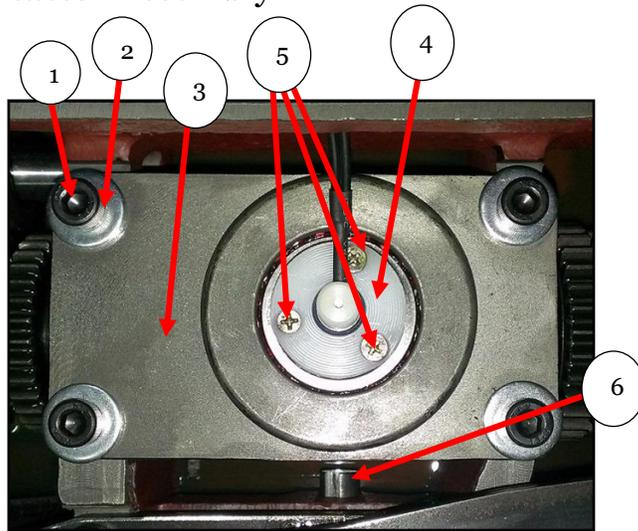

Item	Part Number	Description
1	9SC01-M6X20	Screw Cap,SKT HD M6X1,0X320
2	9MW00-W6	Flat Washer, M6
3	8000-Z49-002	Center Contact Mounting Bracket
4	8000-Z49-001	Center Contact Housing
5	9SC04-M3X27	Screw Cap,SKT HD M3X1,0X27
6	8000-Z65-001	Axis
7	8000-Z43	Drive Shaft Bevel Gear
8	9MW06-0035	Flat Washer, M6
9	9MN06-0035	Lock Nut
10	8000-Z42	Stationary Bevel Gear
11	8000-35X85MM	Axis
12	9KE00-7X7X13MM	Key (Unseen)
13	8000-Z59-001	Speed Adjustment Knob
14	8000-Z59-002	Speed Adjustment Knob
15	8000-Z59-003	Speed Adjustment Knob
16	8000-Z66-001	Transmission Housing Cover

This page intentionally left blank

SECTION 5. FEEDER DRIVE SYSTEM

	<u>Page</u>
Figure 22. Feeder Drive System	<u>112</u>

NOTICE

SJ4AC/D, DI, DI2, SJ3AC/D and DL

Group Number Represents Machine Diameter:

31" thru 36"	Group 5
26" thru 30"	Group 0
21" thru 25"	Group 1
16" thru 20"	Group 2
11" thru 15"	Group 3

SJ4AC/DI3

16" thru 20"	Group 1
11" thru 15"	Group 2

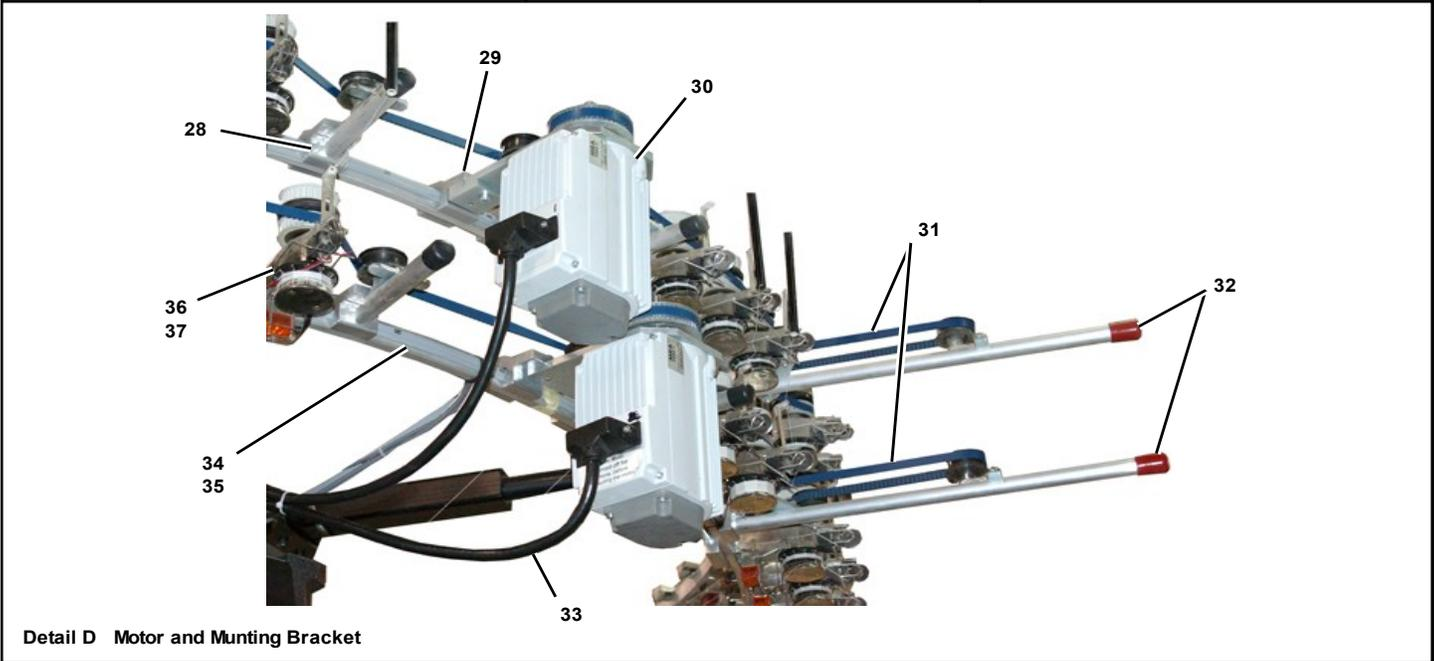
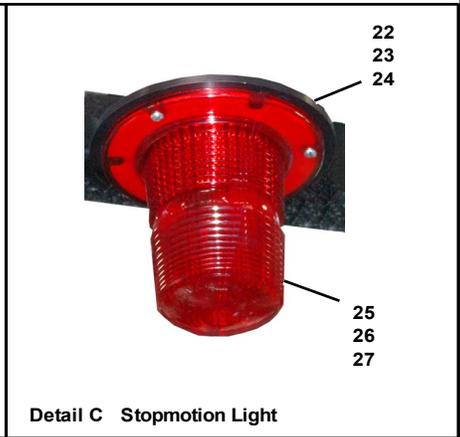
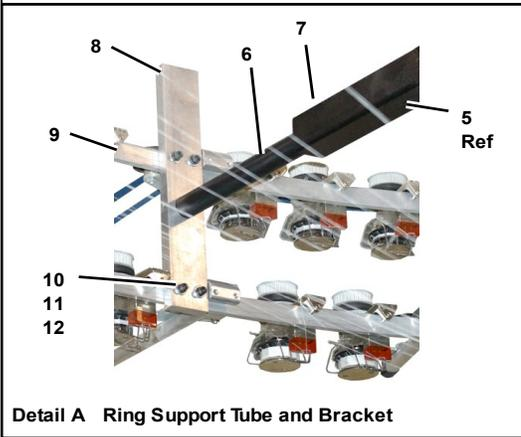
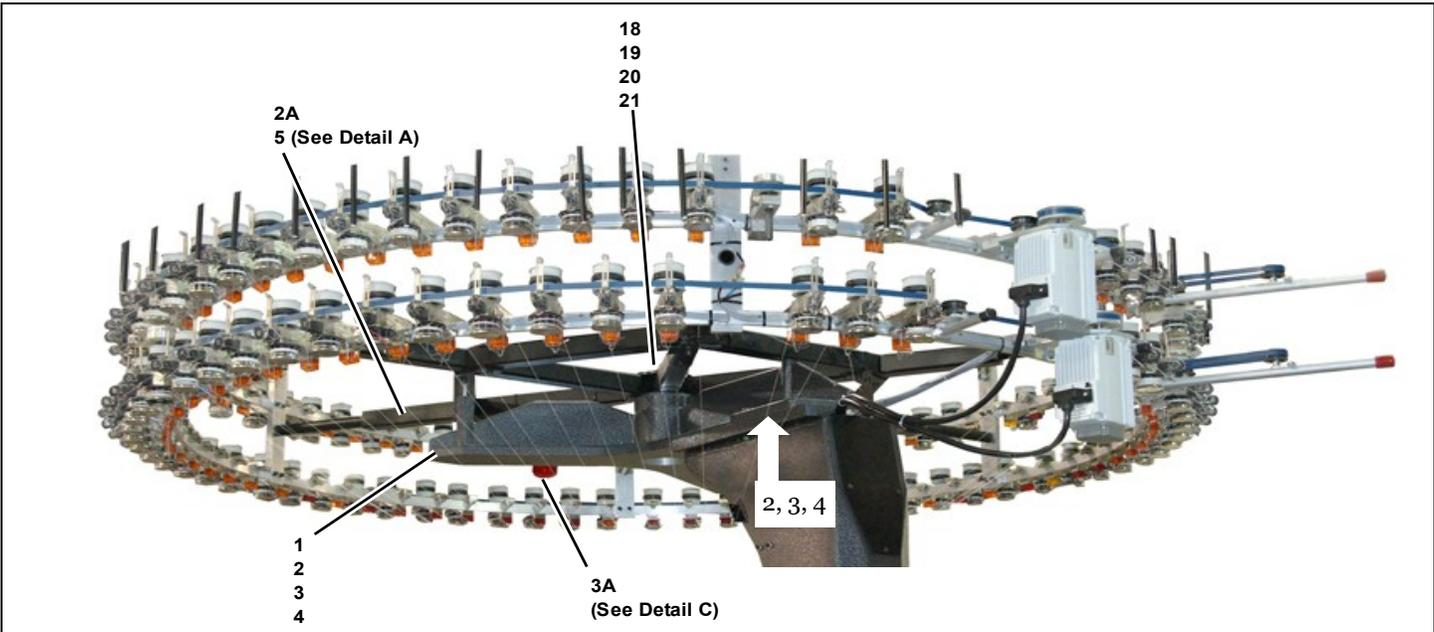
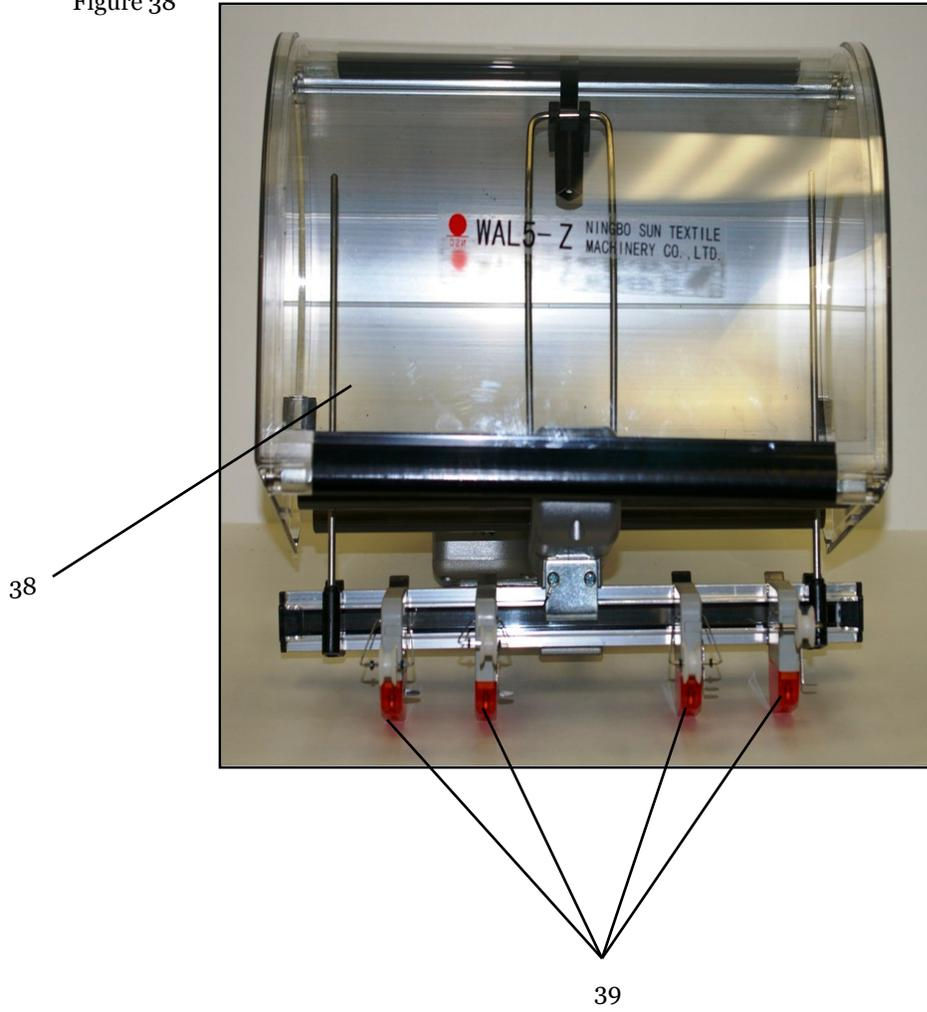

Figure 22. Feeder Drive System

Item	Part Number	Description
1A	No P/N	Feeder Drive Assembly
2A		Feeder Mounting Assembly
	119036-0100	Group 0 (26" to 30" Diameter Machines)
	119036-0101	Group 1 (21" to 25" Diameter Machines)
	119036-0102	Group 2 (16" to 20" Diameter Machines)
	119036-0103	Group 3 (11" to 15" Diameter Machines)
		Includes Items 5 thru 21
3A	118549	Stopmotion Lamp Assembly
		Includes Items 22 thru 27
1	106792-01	Support
2	806584-12050	Socket Head cap Screw, M12 x 1.75 x 50 mm
3	806597-12	Lock Washer, M12
4	806596-12	Flat Washer, M12
5	106898	Ring Support Frame
6	WE90215-16	Support Tube, 16" Long
7	806592-0808	Socket Head Set Screw, M8 x 1.25 x 8 mm
8	WE91212-14D	Ring Mounting Bracket
9		Feeder Mounting Ring
	WE66495-80	Group 0 (26" to 30" Diameter Machines)
	WE66495-74	Group 1 (21" to 25" Diameter Machines)
	WE66495-68	Group 2 (16" to 20" Diameter Machines)
	WE66495-62	Group 3 (11" to 15" Diameter Machines)
10	1806196-01Z	Socket Head Set Screw, 1/4 - 20 x 1 1/8"
11	806380	Lock Washer, 1/4"
12	6164	Flat Washer, 1/4"
13	WE91279-3YA	Fan Mounting Assembly
		Includes Items 14 thru 17
14	WE91345A	Post and Plate Assembly
15	WE91281	Spacer
16	806584-08075	Socket Head Cap Screw, M8 x 1.25 x 75 mm
17	806597-08	Lock Washer, M8
18	805143-02A	Center Shaft Clamp
19	806584-06025	Socket Head Cap Screw, M6 x 1 x 25mm
20	806597-06	Lock Washer, M6
21	806596-06	Flat Washer, M6
22	775437-46	Plate
23	806586-05010	Countersink Socket Head Cap Screw, M5 x .8 x 10mm
24	104604	Button Head Cap Screw, M4 x .7 x 3.3 mm
25	775193-02	Stopmotion Lamp
26	775056-3	Housing
27	775055-1	Pin
28	807712-06	Short Tensioner
29	777104	Motor Mounting Bracket
30	777105	Feeder Drive Motor
31		Feeder Drive Belt
	807639-7800	Group 0 (26" to 30" Diameter Machines)
	807639-7200	Group 1 (21" to 25" Diameter Machines)
	807639-6800	Group 2 (16" to 20" Diameter Machines)
	807639-6400	Group 3 (11" to 15" Diameter Machines)
32	807712-05	Long Tensioner (Not Spring Loaded)
33	777103	Motor Connection Cable

Lycra Feeder with Dust Cover

Figure 38



Item	Part Number	Description
34	807638	Contact Cable
35	807638-01	Contact Cable Protective End
36		Memminger Positive Yarn Feeder
	807655-090L	No Knot (Slub) Catcher
	807655-091L	0.4 mm Knot (Slub) Catcher
	807655-092L	0.6 mm Knot (Slub) Catcher
	807655-093L	0.8 mm Knot (Slub) Catcher
	807655-094L	1.0 mm Knot (Slub) Catcher
	807655-095L	1.2 mm Knot (Slub) Catcher
37		Knot (Slub) Catcher
	807655-0.4L	0.4 mm
	807655-0.5L	0.5 mm
	807655-0.6L	0.6 mm
	807655-0.8L	0.8 mm
	807655-1.0L	1.0 mm
	807655-1.2L	1.2 mm
	808355-27	Fan, Top, Pai Lung
	119132-03	4 Tier Stop Motion Light (GDN-Not Pictured)
38	807670-03	Lycra Feeder (With Dust Cover Installed)
39		Stopmotion

SECTION 6. CENTER SHAFT AND SPREADER ASSEMBLY

	<u>Page</u>
Figure	23. Center Shaft and Spreader Assembly <u>117</u>

NOTICE

SJ4AC/D, DI, DI2,SJ3AC/D and DL

Group Number Represents Machine Diameter:

31" thru 36"	Group 5
26" thru 30"	Group 0
21" thru 25"	Group 1
16" thru 20"	Group 2
11" thru 15"	Group 3

SJ4AC/DI3

16" thru 20"	Group 1
11" thru 15"	Group 2

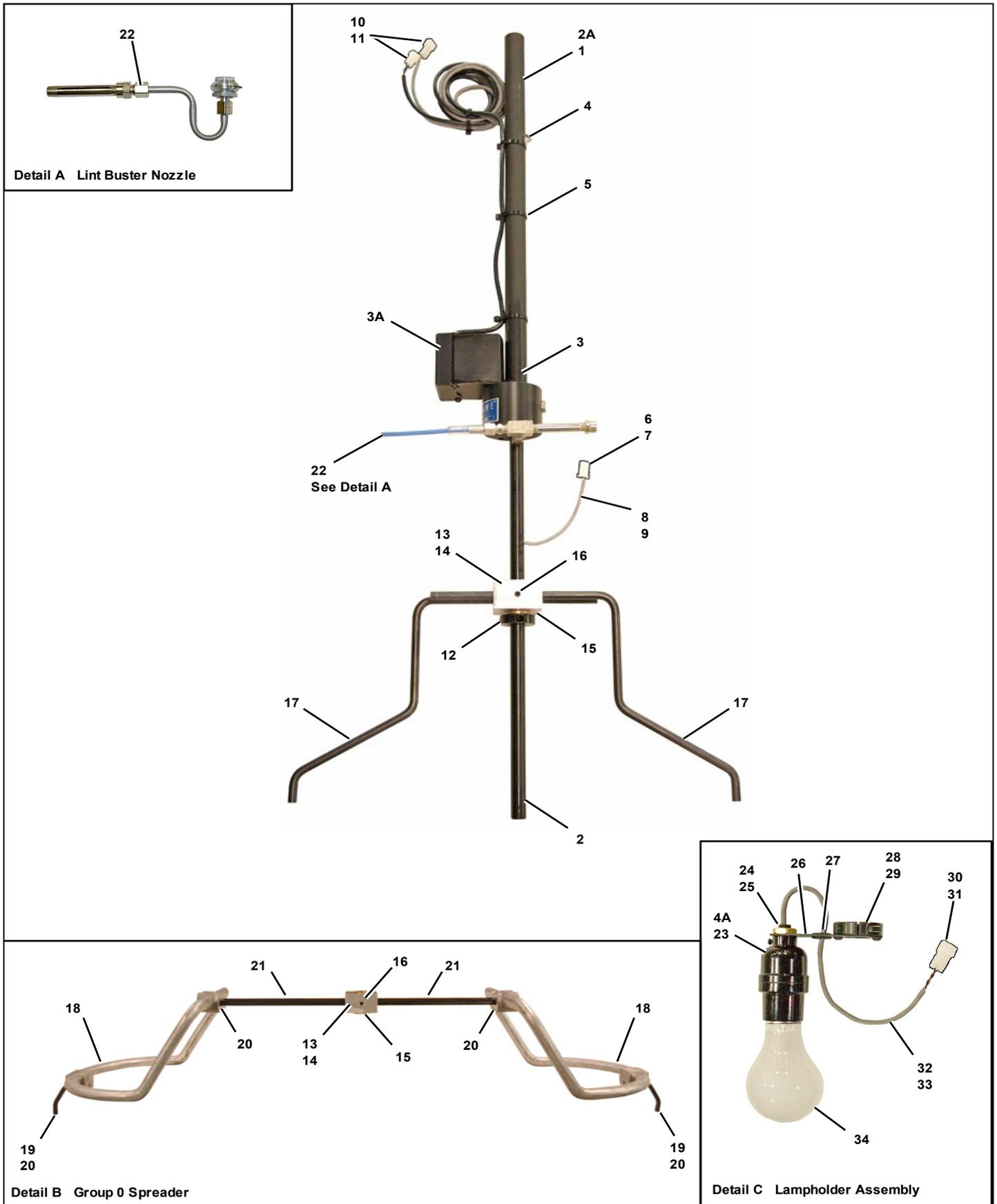
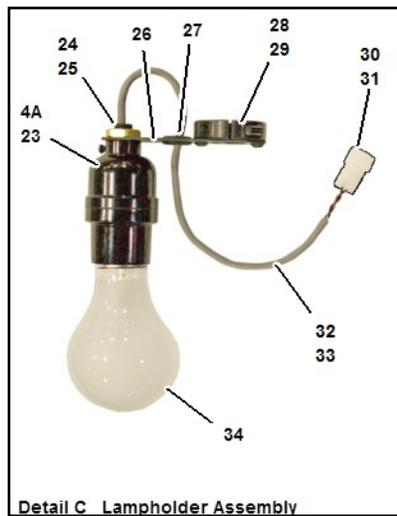
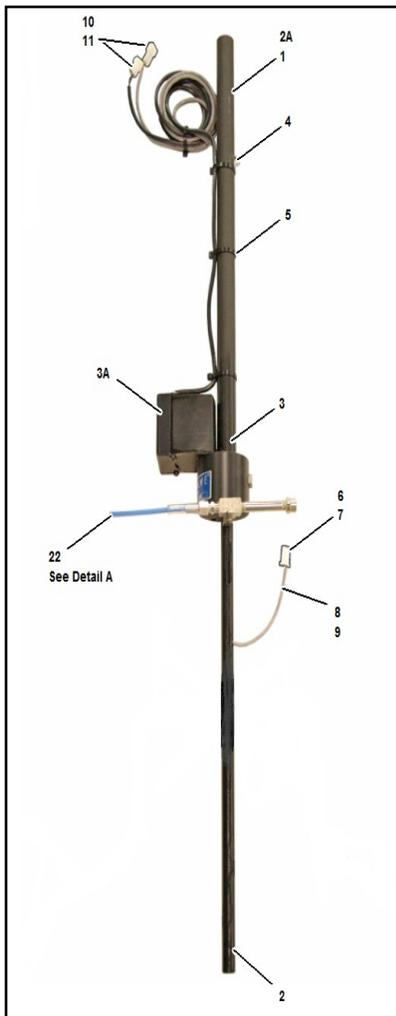
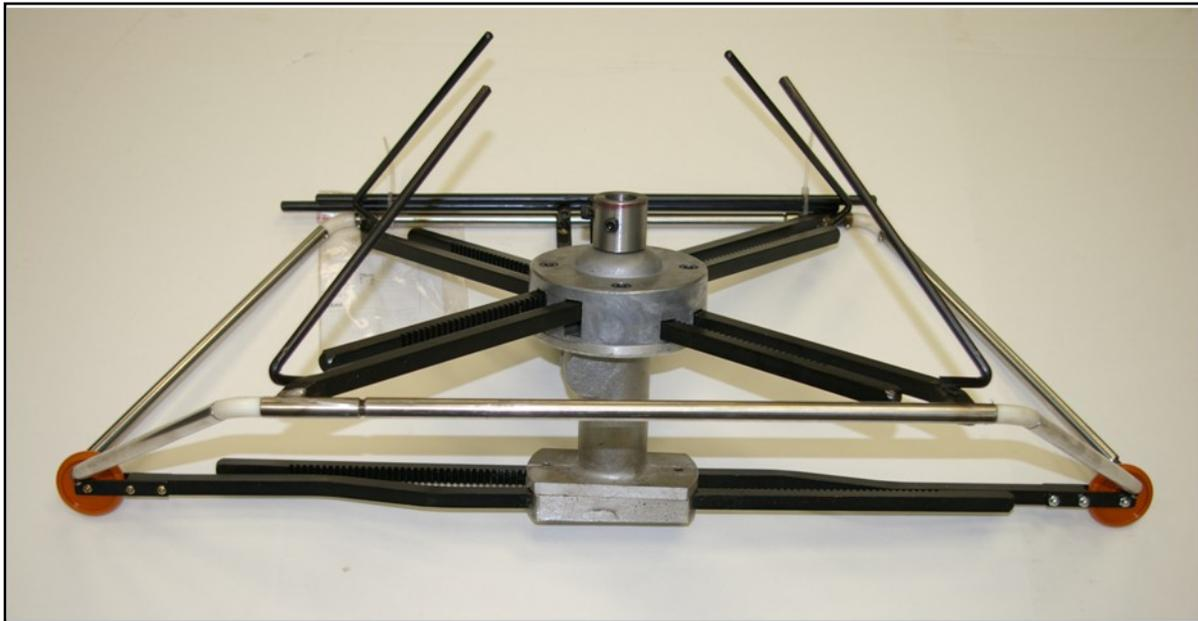

Figure 23. Center Shaft and Spreader Assembly

Item	Part Number	Description
1A	119052-00 119052-01 119052-02 119052-0248 119052-03 119052-0348	Center Shaft and Spreader Assembly Group 0 All Frame Sizes (26" to 30" Diameter) Group 1 All Frame Sizes (21" to 25" Diameter) Group 2 Standard and Industrial Frame (16" to 20" Diameter) Group 2 Jumbo Frame (16" to 20" Diameter) Group 3 Standard and Industrial Frame (11" to 15" Diameter) Group 3 Jumbo Frame (11" to 15" Diameter) Includes Items 2A and 1 thru 21
2A	118527-08 118527-01	Center Shaft Assembly All Frame Sizes Except Group 2 and 3 Jumbo Frame Groups 2 and 3 Jumbo Frame Includes Items 1 thru 3
3A	808409-2534 808409-1824 808409-1417 808409-1113	Flutter Blower Assembly Machine Diameters 25" to 30" Machine Diameters 18" to 24" Machine Diameters 14" to 17" Machine Diameters 11" to 13" Includes Item 22
4A	117088-03	Lamp Holder Assembly Includes Items 23 thru 33
1	104065-02	Upper Shaft
2		Lower Shaft
	104066-11	All Frame Sizes Except Group 2 and 3 Jumbo Frame
	104066-01	Groups 2 and 3 Jumbo Frame
3	006768	Roll Pin, 1/8" Dia x 7/8"
4	7969	Nylon Insulator
5	17079	Cable Tie
6	775053-3	Housing
7	775054-1	Socket
8	775514-1811	Wire, Light Blue
9	775514-183	Wire, Red
10	775056-2	Housing
11	775055-1	Pin
12	806286	Clamping Collar
13	105772	Spreader Coupling Assembly Includes Items 14 and 15
14	105772-01	Coupling
15	806454	Flanged Bushing
16	6116	Socket Head Set Screw, 1/4 - 20 x 1/4"
17		Spreader
	106597-1	Group 1 (21" to 25" Diameter Machines)
	106597-2	Group 2 (16" to 20" Diameter Machines)
	106597-3	Group 3 (11" to 15" Diameter Machines)
		See Detail B for Group 0 (26" to 30" Diameter) Spreader
18	26327	Spreader, Group 0
19	26285	Bent Extending Rod, Group 0
20	16932	Socket Head Set Screw, 1/4 - 20 x 1/2" Nylok, Group 0
21	1882-A	Extending Rod, Group 0

“Cadratex Style Spreader”



Detail C Lampholder Assembly

Item	Part Number	Description
22	808374-03 808374-04 808374-05 808383-300 808383-301 808383-302 808383-303	Blower Nozzle <u>Blue Flutter Tube Style</u> 11" thru 17" Diameter Machines 18" thru 23" Diameter Machines 24" thru 30" Diameter Machines (Includes Blue Tube and Spring Assembly, P/N 808383) <u>Lint Buster Style</u> (See Detail A) Group 0 (26" to 30" Diameter Machines) Group 1 (21" to 25" Diameter Machines) Group 2 (16" to 20" Diameter Machines) Group 3 (11" to 15" Diameter Machines)
23	30460	Socket
24	103230	Nipple, 1/8 - 27 Straight
25	806855	Hex Nut, 1/8 - 27 Straight
26	103228	Support
27	7796	Grommet
28	103229-02	Support Clamp
29	805177	Button Head Cap Screw, 8 - 32 x 3/8"
30	775056-2	Housing
31	775055-1	Pin
32	775514-1811	Wire, Light Blue
33	775514-183	Wire, Red
34	7912	Light Bulb
35	7130-F40C	Cadratex Style Spreader
	7130-F13C	Spreader 13"- 14" (W/R)
	7130-F13CNR	Spreader 13"- 14" (W/O Roller)
	7130-F16C	Spreader 15"- 17" (W/R)
	7130-F16CNR	Spreader 15"- 17" (W/O Roller)
	7130-F20C	Spreader 18"- 21" (W/R)
	7130-F20CNR	Spreader 18"- 21" (W/O Roller)
	7130-F30C	Spreader 22"- 28" (W/R)
	7130-F30CNR	Spreader 22"- 28" (W/O Roller)
	7130-F40C	Spreader 30"- 36" (W/R)
	7130-F40CNR	Spreader 30"- 36" (W/O Roller)
	7130-F42C	Spreader 38"- 40" (W/R)
7130-F42CNR	Spreader 38"- 40" (W/O Roller)	
36	108245	Bushing (Not pictured)
37	806590-0825	Flat Point Soc Set Sc (Qty. 2)

This page intentionally left blank

SECTION 7. KNITTING ELEMENTS

	<u>Page</u>
Figure 24. Knitting Elements	<u>123</u>
Figure 25. Sinker Cam Ring and Section Mounting Assembly	<u>125</u>
Figure 26. Yarn Carrier Mounting and Guide Ring Assembly	<u>127</u>
Figure 27. & 27B Cylinder Section Block Assembly.....	<u>129</u>
Figure 28. & 28B. Sinker Section Block Assembly.....	<u>132</u>

NOTICE

SJ4A/D, DI, DI2, SJ3A/D and DL

Group Number Represents Machine Diameter:

31" thru 36"	Group 5
26" thru 30"	Group 0
21" thru 25"	Group 1
16" thru 20"	Group 2
11" thru 15"	Group 3

SJ4A/DI3

16" thru 20"	Group 1
11" thru 15"	Group 2

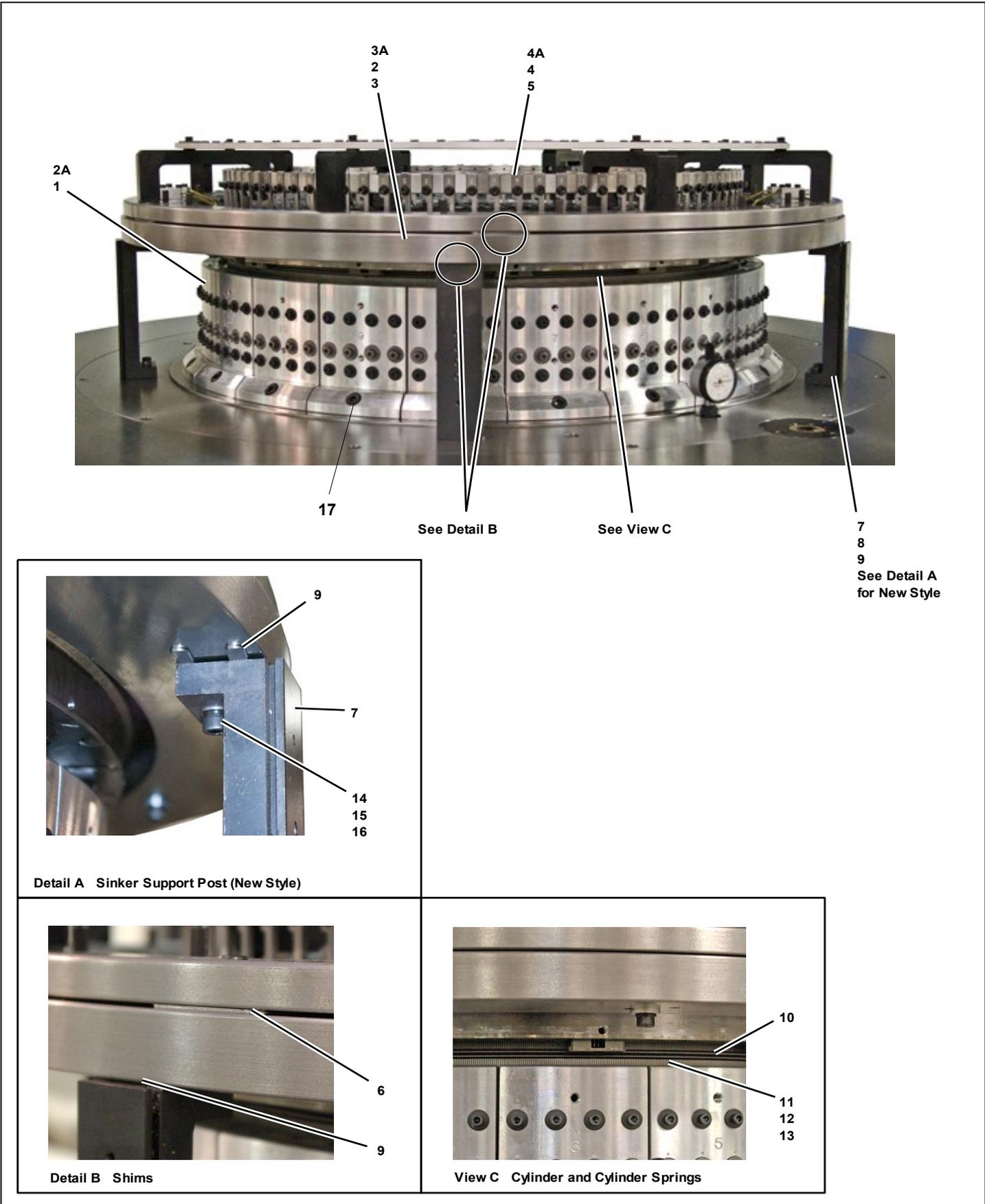

Figure 24. Knitting Elements

Item	Part Number	Description
1A	119010-DIA	Knitting Elements Assembly Note: See the machine serial plate for the proper needle and sinker part numbers.
2A	119011-DIA CSK	Cylinder Section Assembly Note: Part number is for a complete set of cylinder section blocks. To order individual cylinder section blocks, use part number 119014-DIA. See Figure 5. for Illustrated Parts Breakdown
3A	119012-DIA 119012-1DIA	Sinker Cam Ring and Section Mounting Assembly Old Style (with Mounting Screw Under Adjustable Carrier Ring) New Style (with Mounting Screw on Sinker Ring Support) See Figure 3. for Illustrated Parts Breakdown
4A	119013-DIA	Yarn Carrier Mounting and Guide Ring Assembly See Figure 4. for Illustrated Parts Breakdown
1	806584-08030	Socket Head Cap Screw, M8 x 1.25 x 30 mm
2	806584-06025	Socket head Cap Screw, M6 x 1 x 25 mm
3	806606-06	Lock Washer
4	806584-06035	Socket Head Cap Screw, M6 x 1 x 35 mm
5	806596-T06	Flat Washer, M6 x .665 x .115 Thick
6	5998-A	Shim, .040" Thick
7	106816 106816-02	Sinker Ring Support Old Style with Tapped Hole at Top New Style with Through Hole at Top
8	806584-06025	Socket Head Cap Screw, M6 x 1 x 25 mm (Used on Old Style Support Post)
9	101132-01 101132-02 101132-03 101132-04	Shim .002" Thick .005" Thick .010" Thick .020" Thick
10	100797-DIA	Cylinder Spring
11	As Specified	Cylinder
12	806961	Socket Head Cap Screw, 5/16-18 x 3.25"
13	60431	Cylinder Washer
14	806584-06035	Socket Head Cap Screw, M6 x 1 x 35 mm (Used on New Style Support Post)
15	806597-06	Lock Washer, M6 (Used on New Style Support Post)
16	806596-06	Flat Washer, M6 (Used on New Style Support Post)
17	806584-08030	Cylinder Section Block Bolt



2
3
10
2A
1

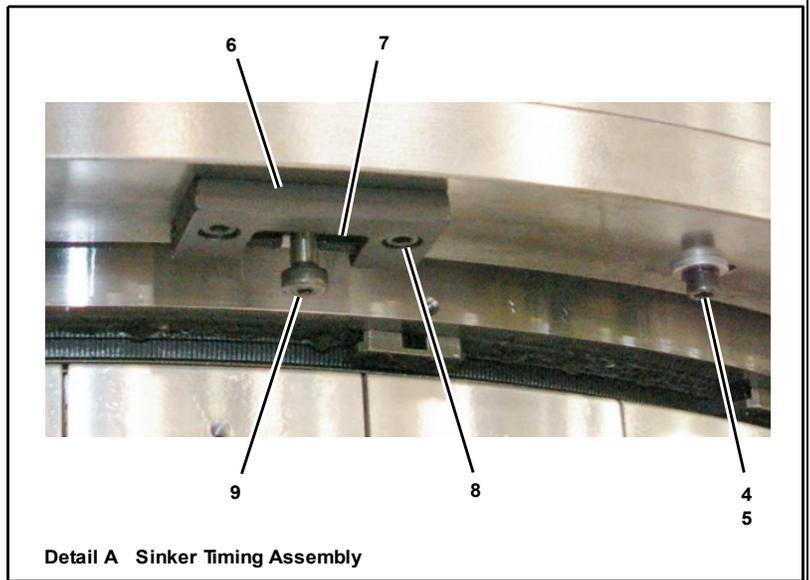

Figure 25. Sinker Cam Ring and Section Mounting Assembly

Item	Part Number	Description
1A	119012-DIA 119012-1DIA	Sinker Cam Ring and Section Mounting Assembly Old Style (with Mounting Screw Under Adjustable Carrier Ring) New Style (with Mounting Screw on Sinker Ring Support) For Next Higher Assembly, See Figure 2.-3A
2A	118978-DIA SSK	Sinker Section Assembly Note: Part number is for a complete set of sinker section blocks. To order individual sinker section blocks, use part number 118978-DIA. See Figure 6. for Illustrated Parts Breakdown
1	806601-06012	Socket Head Shoulder Screw, M6 x 1 x 12 mm
2	106817-DIA 106817-1DIA	Sinker Cam Ring Old Style (with Mounting Screw Under Adjustable Carrier Ring) New Style (with Mounting Screw on Sinker Ring Support)
3	106818-DIA	Adjustable Sinker Cam Ring (Not Shown in Illustration)
4	806584-06025	Socket Head Cap Screw, M6 x 1 x 25 mm
5	806596-T06	Flat Washer, M6 x .665 x .115 Thick
6	104766	Sinker Timing Shoe
7	806590-0630	Socket Head Set Screw, Flat Point, M6 x 1 x 30 mm
8	806584-06012	Socket Head Cap Screw, M6 x 1 x 12 mm
9	806601-06025	Socket Head Shoulder Screw, M6 x 1 x 24 mm
10	806601-06012	Sinker Section Block Bolt

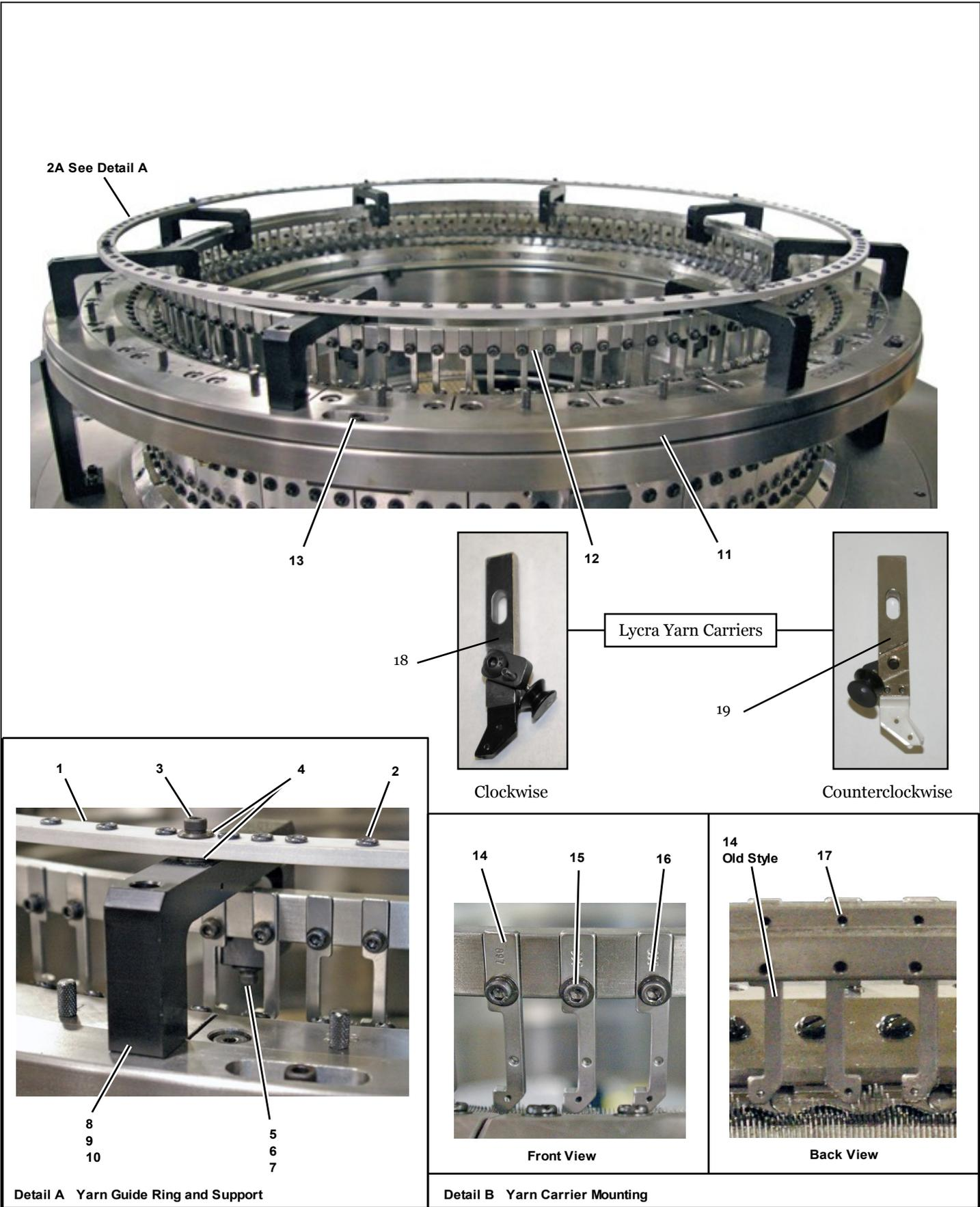
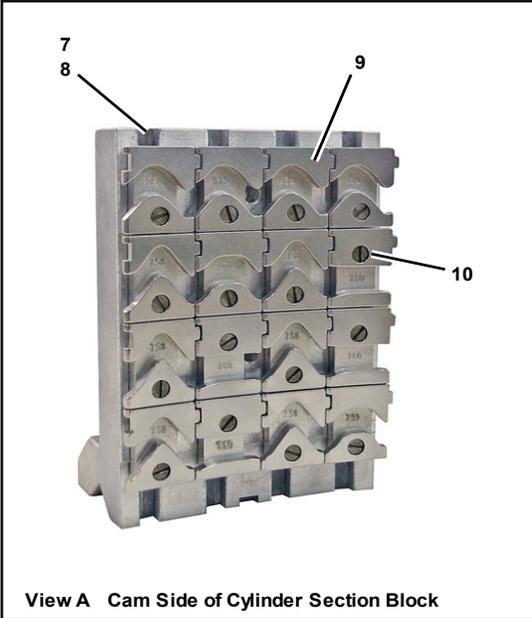
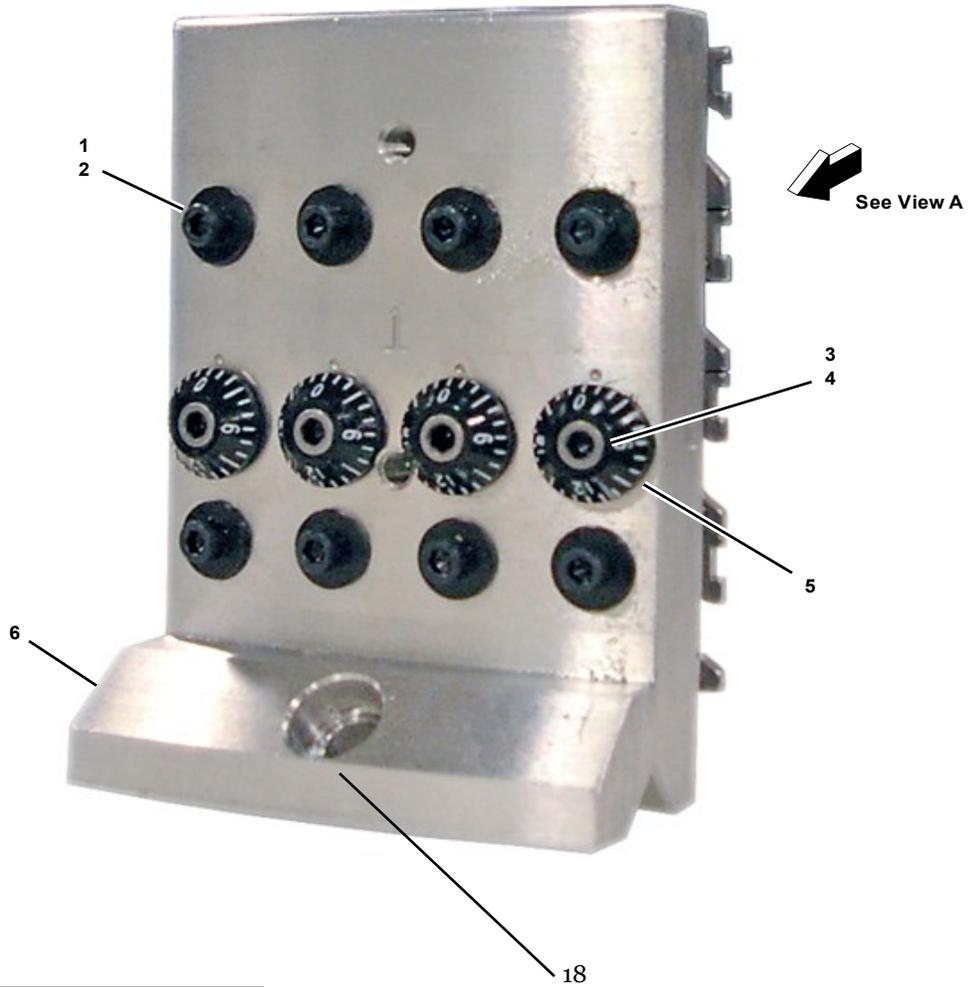

Figure 26. Yarn Carrier Mounting and Guide Ring Assembly

Item	Part Number	Description
1A	119013-DIA	Yarn Carrier Mounting and Guide Ring Assembly For Next Higher Assembly, See Figure 24.-4A
2A	110557-DIA+2" 119054-DIA	Yarn Guide Ring Assembly Old Style (Do Not Order, use the New Style ring. P/N 119054-DIA) New Style Includes Items 1 and 2
1	101020-DIA+2" 106959-DIA	Yarn Guide Ring Old Style (Do Not Order, use the New Style ring, P/N 106959-DIA) New Style
2	7200	Porcelain Yarn Guide (Attaches to Yarn Guide Ring with Super Bonder, P/N 806385-04)
3	6280	Socket Head Cap Screw, 10-32 x 5/8"
4	6166	Beveled Washer, No. 10 On machines using Yarn Guide Ring 101020-DIA+2" (see Item 1), a yarn guide assembly is used, part number 117339 in place of Item 4.
5	6333	Socket Head Cap Screw, 10-32 x 7/8"
6	6165	Lock Washer, No. 10
7	6166	Beveled Washer, No. 10
8	103442	Support Bracket
9	806617-15608	Spirol Pin
10	806584-05025	Socket Head Cap Screw, M5 x .8 x 25 mm
11	106819-DIA	Adjustable Carrier Ring
12	103380-DIA	Yarn Carrier Mounting Ring
13	806584-06025	Socket Head Cap Screw, M6 x 1 x 25 mm
14	106897 106985 106897-002 106897-003 104385-02	Yarn Carrier, Jersey Fabric Jersey Fabric New Style 2 End Fleece Fabric (1/2 Feeds Only) Zirconium Carrier (White) Standard Carrier with a Porcelain Insert Old Style 2 End Fleece Carrier (Mounts Backwards) Note: If replacing all of the <i>Old Style</i> 2 end fleece carriers, use the <i>New Style</i> carrier, part number 106985-01
15	6560	Socket Head Cap Screw, 8-32 x 1/2"
16	6282	Flat Washer, No. 8
17	6906	Socket Head Set Screw, 6-32 x 3/16"
18	119149-002	CW Zirconium Lycra Carrier Assembly (4 Feeds or 3 Feeds per inch)
19	L119149-002	CCW Zirconium Lycra Carrier Assembly (4 Feeds or 3 Feeds per inch)
*20	106897-002	CW Zirconium Yarn Carrier (Not Pictured) (4 Feeds or 3 Feeds per inch)
*21	L106897-002	CCW Zirconium Yarn Carrier (Not Pictured) (4 Feeds or 3 Feeds per inch)

SJ4A/D Cylinder Section



View A Cam Side of Cylinder Section Block

Figure 27. Cylinder Section Block Assembly
(Sheet 1 of 2)

SJ3A/D and SJ3A/DL

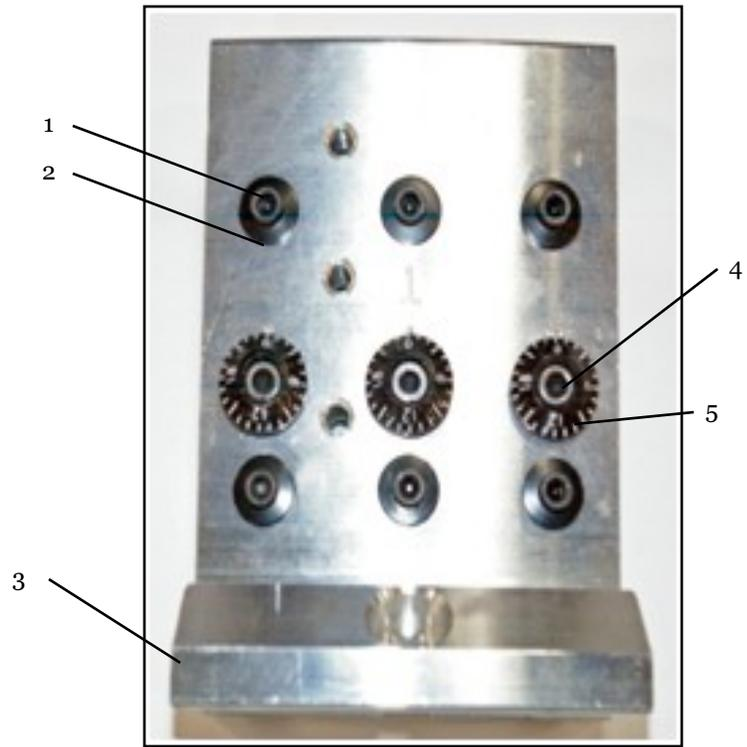

SJA3/D Section

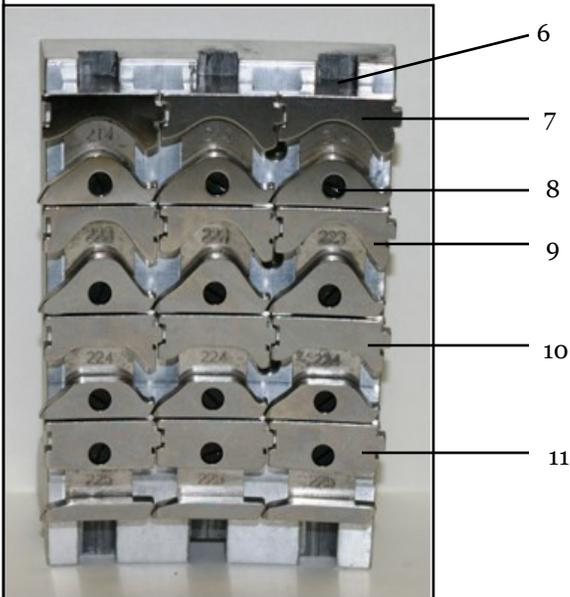

SJA3/DL Section

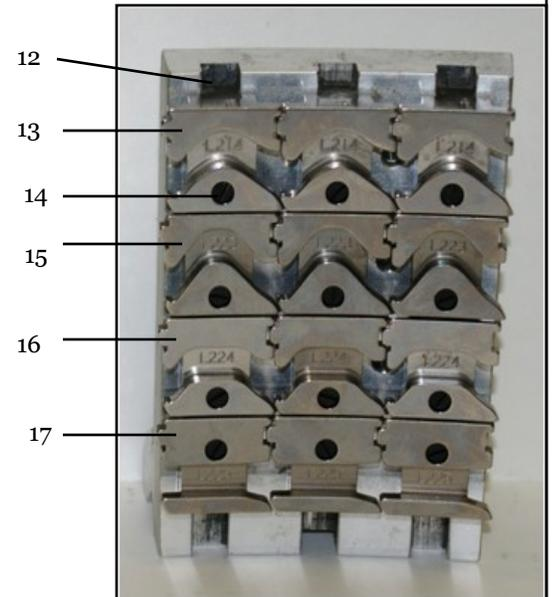

(Sheet 2 of 2)

Item	Part Number	Description
1A	119014-DIA	Cylinder Section Block Assembly See For Next Higher Assembly, See Figure 22.-2A
1	6287	Socket Head Cap Screw, 8-32 x 3/4"
2	806257	Belleville Washer, No. 8
3	101293	Stitch Adjusting Barrel
4	806376	O-Ring, 1/2" ID x 5/8" OD x 1/16" Wide
5	101291	Stitch Adjusting Dial
6	106820-DIA	Cylinder Section Block
7	103372	Cylinder Cam Post
8	805961	Dowel Pin, 3/32" x 1/4" Long
9	As Specified	Cylinder Cam
	106935- <u>TAB</u> -	4.0mm Latch Cam, Raising (If 28 Cut Use 106582-Tab, 4.5 mm Latch Cam)
	106758- <u>TAB</u>	6.0 mm Latch Cam, Raising
	106759- <u>TAB</u>	- 6.0 mm Latch Cam, Tuck
		<u>TAB</u> =
		01 = 28-36 in.
		02 = 22-26 in.
		• 03 = 19-21 in.
		• 04 = 15-18 in.
		• 05 = 12-14 in.
		• 06 = 9-11 in.
10	101230-01	Cylinder Cam Screw
11	6287	Socket Head Cap Screw, 8-32 x 3/4"
12	806257	Belleville Washer, No. 8

Item	Part Number	Description
1	6287	Screw Cap Socket Head 8-32 X 3/4
2	806257	Belleville Washer, No. 8
3	119142-30P- <u>TAB</u>	Cylinder Section Block
4	101293	Stitch Adjusting Barrel
5	101291	Stitch Adjusting Dial
6	103399	Post Cylinder Cam
7	108217- <u>TAB</u>	4.0mm Latch Raising Cam
8	101230-01	Cylinder Cam Screw
9	108223- <u>TAB</u>	6.0 mm Latch Cam, Raising
10	108224- <u>TAB</u>	6.0 mm Latch Cam, Tuck
11	108225- <u>TAB</u>	6.0 mm Latch Cam, Welt
12	103399	Post Cylinder Cam
13	L108214- <u>TAB</u>	4.0mm Latch Raising Cam
14	101230-01	Cylinder Cam Screw
15	L108224- <u>TAB</u>	6.0 mm Latch Cam, Raising
16	L108225- <u>TAB</u>	6.0 mm Latch Cam, Tuck
17	L108225- <u>TAB</u>	6.0 mm Latch Cam, Welt
*18	806584-08030	Cylinder Section Screws M8X1 25X30 DI (All Models of SJ4/D and SJ3A/D) Not Shown.

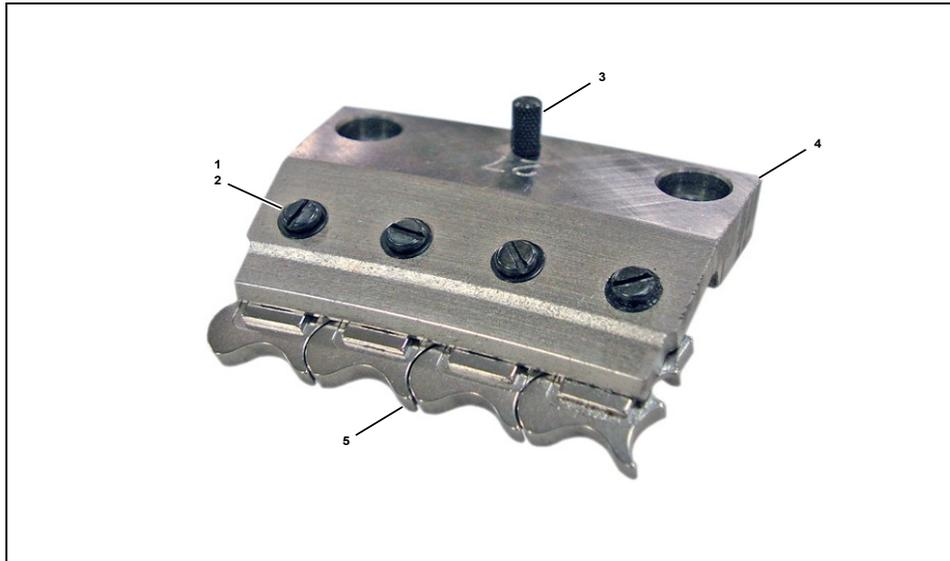

Figure 27. Sinker Section Block Assembly

(Sheet 1 of 2)

Item	Part Number	Description
1A	118978-DIA	Sinker Section Block Assembly See For Next Higher Assembly, See Figure 3.-2A
1	806315-01	Sinker Cam Screw
2	806561-01	Belleville Washer, No. 8
3	101093-01	Knurled Knob
4		Sinker Section Block
	106776-DIA	Standard
	106777-DIA	Lubrication
5	106877-DIA	25 Degree SJ4A/D Double Push Sinker Cam
	108057-DIA	25 Degree SJ4A/D Triple Push Sinker Cams

(*NOTE)- If Triple Push Sinker are used to replace existing Double Push Sinker Cams additional lubricating oil lines are required.

SJ4A/DELTA Field Conversion : Double Push Cams to Triple Push Cams

Depending on the type of oiler, the following is a list of items that are required to install the additional oil nozzles that are required to lubricate the Triple Push Caming.

VPL Mist Oiler, Uniwave PJ419 Oiler (REF 119026-10 Oil Dist. Kit)

Parts Required:

QTY	2ea	808450-03	Nozzle Oil Mist 20/90 DEG SN
QTY	30 Ft	007394-02	Tubing, Yellow Flexible
QTY	4ea	806584-04025	Screw, Socket Head Cap

IRO Memminger Pulsonic 5.2 Oiler (REF 119026-20 Oil Dist. Kit)

Parts Required:

QTY	1ea	808450-13	Nozzle Oil Mist 20/90 DEG SN
QTY	15 Ft	808374-38	Tubing, Pulsonic 4 Oiler
QTY	2ea	806584-04025	Screw, Socket Head Cap

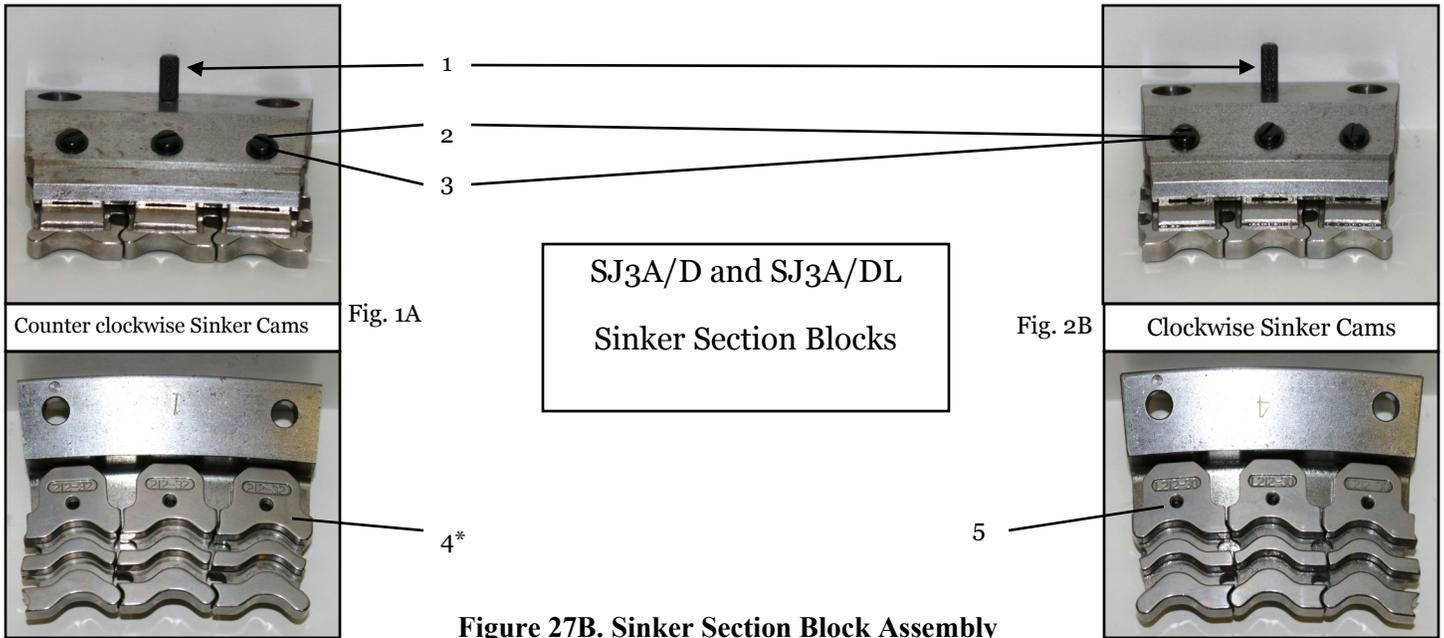

Figure 27B. Sinker Section Block Assembly

(Sheet 2 of 2)

Item	Part Number	Description
Fig. 1A	L119144-DIA P	Sinker Section Block Assembly (Counter Clockwise Direction)
Fig. 2B	119144-DIA P	Sinker Section Block Assembly (Clockwise Direction)
1	101093-01	Knurled Knob SJ3A/D & L
2	806561-01	Belleville Washer, No. 8 SJ3A/D & L
3	806315-01	Sinker Cam Screw SJ3A/D & L
4*	L108212-DIA	Sinker Cam 4.0mm Latch CCW
5	108212-DIA	Sinker Cam 4.0mm Latch CW

Depending on the type of oiler, the following is a list of items that are required to install the additional oil nozzles that are required to lubricate the Triple Push Caming.

Pai Lung & Uniwave PJ419 Oiler (REF 119026-10 Oil Dist. Kit)

Parts Required:

QTY	2ea	808450-03	Nozzle Oil Mist 20/90 DEG SN
QTY	30 Ft	007394-02	Tubing, Yellow Flexible
QTY	4ea	806584-04025	Screw, Socket Head Cap

IRO Memminger Pulsonic 5.2 Oiler (REF 119026-20 Oil Dist. Kit)

Parts Required:

QTY	1ea	808450-13	Nozzle Oil Mist 20/90 DEG SN
QTY	15 Ft	808374-38	Tubing, Pulsonic 4 Oiler
QTY	2ea	806584-04025	Screw, Socket Head Cap

This page intentionally left blank

SECTION 8. FILTER FLOW 2000

	<u>Page</u>
Figure 29. Filter Flow 2000 Assembly	<u>135</u>

NOTICE

SJ4A/D, DI, DI2, SJ3A/D and DL

Group Number Represents Machine Diameter:

31" thru 36"	Group 5
26" thru 30"	Group 0
21" thru 25"	Group 1
16" thru 20"	Group 2
11" thru 15"	Group 3

SJ4A/DI3

16" thru 20"	Group 1
11" thru 15"	Group 2

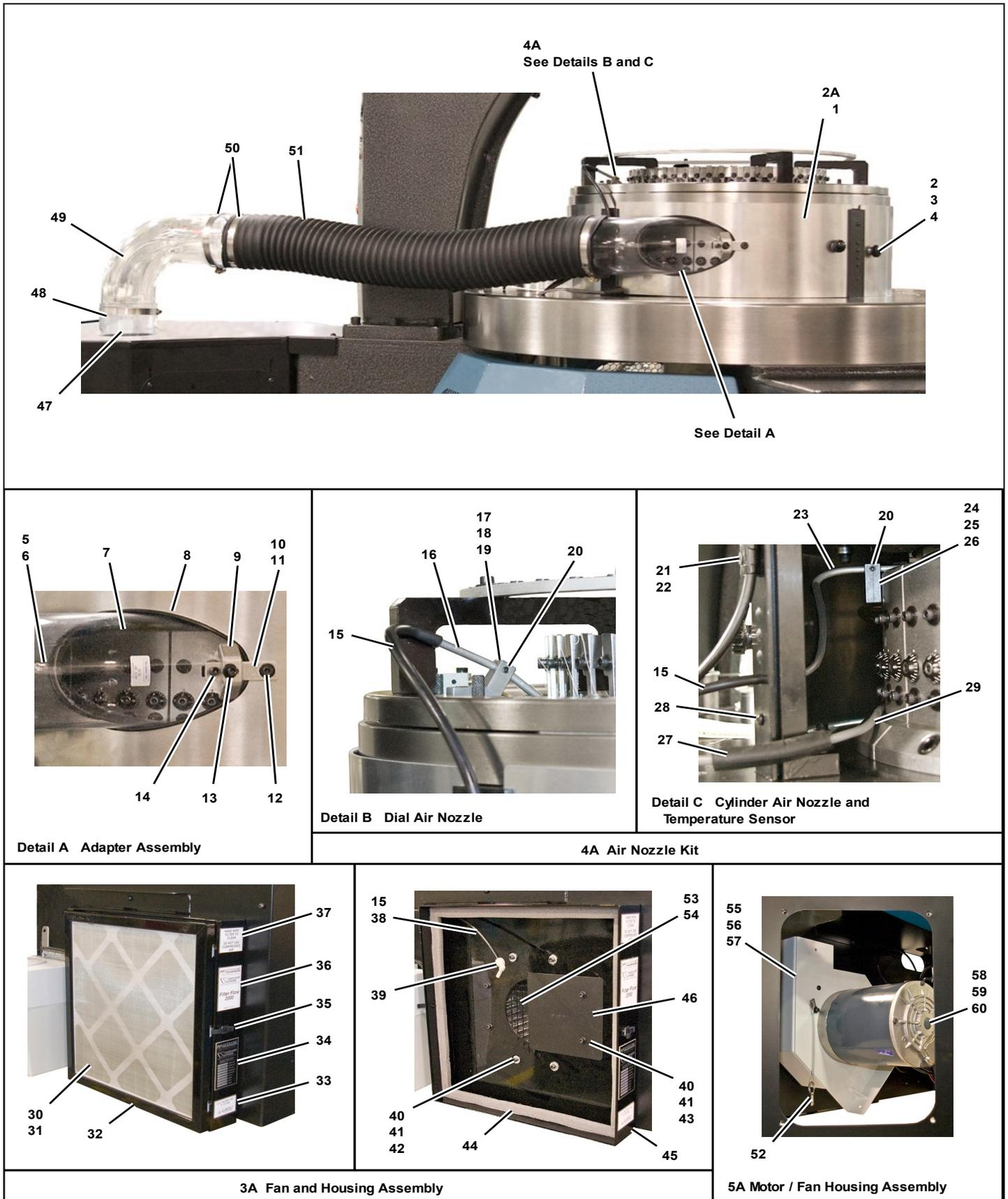

Figure 29. Filter Flow 2000 Assembly
(Sheet 1 of 2)

Item	Part Number	Description
1A	No P/N	Filter Flow 2000
2A	300-SJ4A/D(Diameter)	Air Chamber Assembly Includes Items 1 thru 14 and 27, 28
3A	205D-(Voltage/Hertz)	Fan Housing Assembly Includes Items 5A and 29 thru 52
4A	30-0020-DELTA	Air Nozzle Kit Includes Items 15 thru 26
5A	30-0100-(Voltage/ Hertz) YP	Motor and Fan Assembly Includes Items 53 thru 60
1		Air Chamber Panel
	30DA-33297-DIA	With Air Inlet
	30BA-33297-DIA	Without Air Inlet
2	20-9529	Knob
3	6612	Flat Socket Head Cap Screw, 10-32 x 3/8"
4	806380	Flat Washer, 1/4"
5	30-0048-1	Eyebolt, 3/8" I.D.
6	30-0049	Lock Nut, 10-24
7	30-0005A	Air Chamber Adaptor
8	806975-250	O-Ring, 5.00" I.D. x 5.25" O.D. x 1/8"
9	30-0051	Clamp
10	30-0006	Bracket
11	30-0007	Clamp
12	806584-05016	Socket Head Cap Screw, M5 x .8 x 16 mm
13	806584-05012	Socket Head Cap Screw, M5 x .8 x 12 mm
14	6456	Socket Head Cap Screw, 10-32 x 3/8"
15	20-9526X	Tubing, 3/4" x .043" Wall
16	20-0812	Dial Air Nozzle
17	20-0836	Mounting Bracket
18	806584-05008	Socket Head Cap Screw, M5 x .8 x 8 mm
19	806441	Roll Pin, 0.094 Diameter x 0.375"
20	806592-0405	Socket Head Set Screw, M4 x .7 x 5 mm
21	30-0052	Tubing Clip
22	806508-11	Flat Phillips Head Screw, No. 6 x 5/8" Self Tapping
23	20-0811	Cylinder Air Nozzle
24	20-0810	Mounting Bracket
25	806584-05016	Socket Head Cap Screw, M5 x .8 x 16 mm
26	6767	Roll Pin, 3/32" x 1/2"
27	30-0082-2	Sensor Cord Protector
28	806691-13	Hole Plug
29	20-9748-10	Temperature Sensor
30	20-9506B	Filter Screen
31	30-0160	Filter
32	30-0150	Filter Frame
33	1806182-02	Patent Label
34	1806182-08	Serial Plate
35	20-9512Y	Latch Assembly
36	1806182-03	Logo Label
37	806178-509	Notice Label
38	20-9510 HW	Grommet, 1/4" I.D. x 3/8" O.D.
39	30-0087	Elbow, 1/4" x 1/4"
40	806584-05016	Socket Head Cap Screw, M5 x .8 x 16 mm

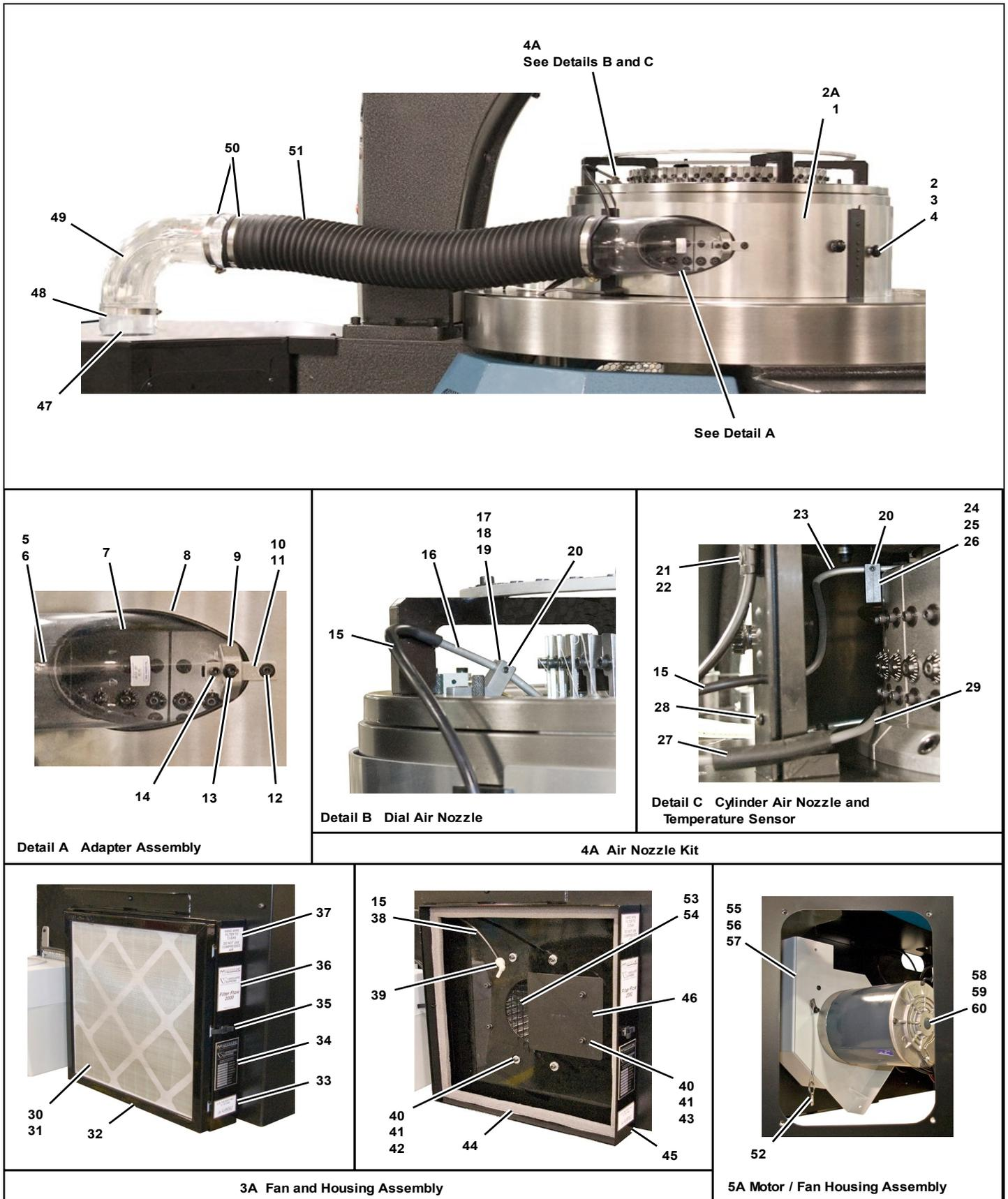

Figure 29. Filter Flow 2000 Assembly
(Sheet 2 of 2)

Item	Part Number	Description
41	806597-05	Lock Washer, M5
42	806596-T06	Flat Washer, M6 x 0.665" O.D. x 0.115" Thick
43	6166	Beveled Washer, No. 10
44	20-9509X	Foam Gasket
45	30-0149	Air Filter Canister
46	30-0149A	Baffle, Groups 2 and 3 Only
47	30-0146	Housing Adapter, 33.25" Long
48	30-0142	Adapter, 4.00" x 4.00"
49	30-0147	Elbow, 4.00" x 10.00"
50	30-0013	Hose Clamp
51	30-0015-33	Flexible Hose, 4.00" x 33.00"
52	30-0014	Release Pin and Lanyard
53	20-0804	Fan
54	20-0805-1	Spacer (Mounts between Fan and Motor)
55	30-0055	Blower Housing
56	805309Z	Hex Head Cap Screw, 3/8-16 x 3/4"
57	806597-10	Lock Washer, M10
58	30-0100	Motor
59	806178-508	Motor Rotation Label (Not Shown)
60	806178-520	Hot Surface Label (Not Shown)
	108211	Cover, Top (FF Duct) Used when Filter Flow is not installed.
	108211-01	Cover, Bottom (FF Motor) Used when Filter Flow is not installed.

This page intentionally left blank

SECTION 9. MACHINE SPECIFICATIONS

		<u>Page</u>
Figure 30.	SJ4A Machine Settings	<u>118</u>
Figure 31.	SJ4A Floor Plan	<u>119</u>
Figure 32.	SJ4A Gate Schematic	<u>120</u>
Figure 33.	SJ4A Schematic (1 of 2)	<u>121</u>
Figure 34.	SJ4A Schematic (2of 2)	<u>122</u>
Figure 35.	SJ4A Selvage Line Cable Harness Diagram.....	<u>123</u>
Figure 36.	SJ4A Feeder Override Kit Electrical Drawing....	<u>124</u>
Figure 37.	SJ4A Ring Size and Feeder Belt Specifications.	<u>126</u>

NOTICE

SJ4A

Group Number Represents Machine Diameter:

31" thru 36" Group 5

26" thru 30" Group 0

21" thru 25" Group 1

16" thru 20" Group 2

11" thru 15" Group 3

SJ4A/DI3

16" thru 20" Group 1

11" thru 15" Group 2

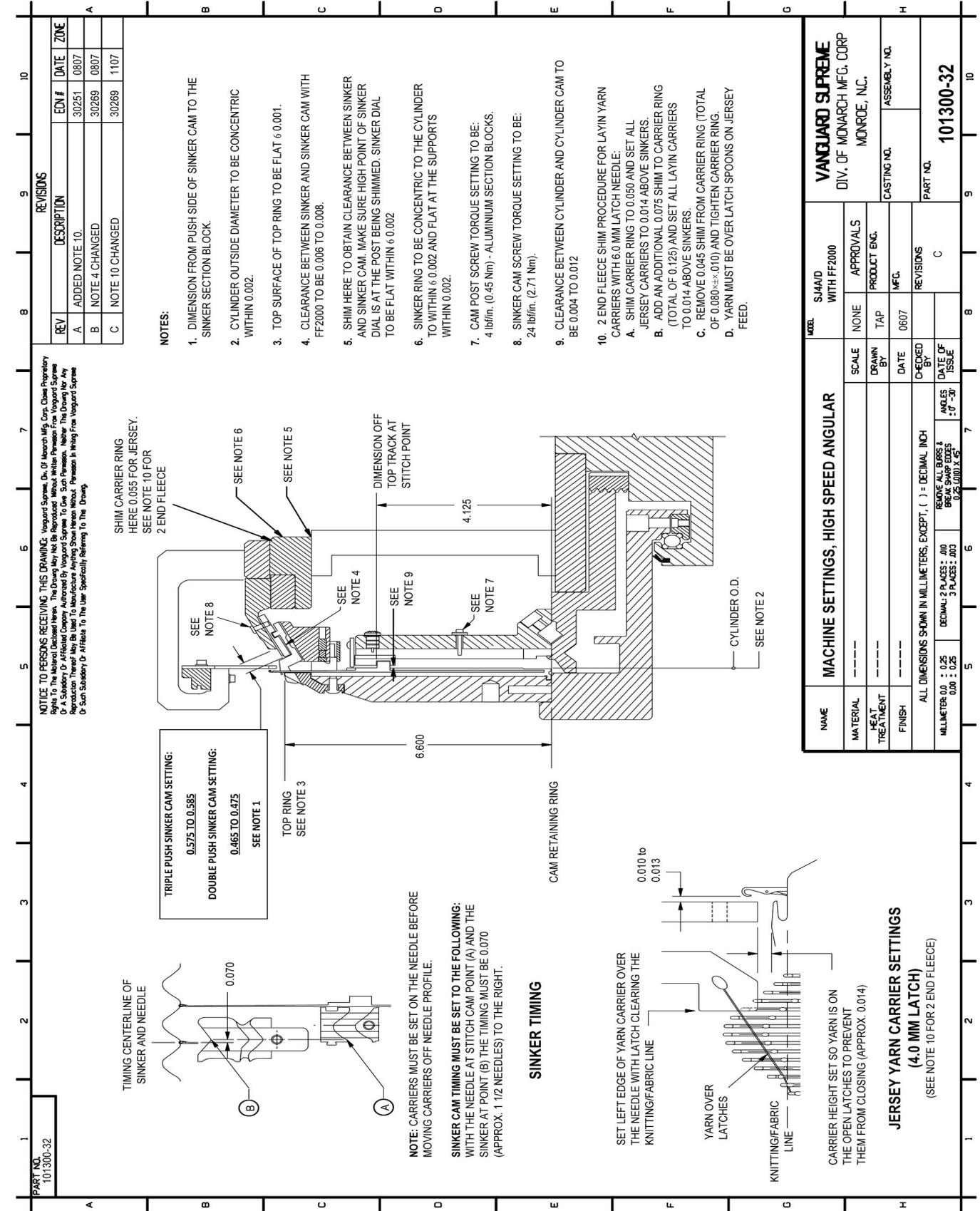

Figure 30, High Speed Angular Machine Settings

SJ4A/D, DI, DI2 FLOOR DIMENSIONS						
Group Size	Dia.	Dim. A	Dim. B	Motorized Quality Wheel Dim. C	Mechanical Quality Wheel Dim. C	Motorized Quality Wheel with Lycra Dim. C
5	31"-36"	201.4 (79.3)	305.3 (120.2)	223.5 (88.0)	248.9 (98.0)	330.2 (130.0)
0	26"-30"	189.0 (74.4)	254.3 (100.1)	203.2 (80.0)	233.7 (92.0)	304.8 (120.0)
1	21"-25"	177.0 (69.7)	242.3 (95.4)	186.9 (74.0)	223.5 (88.0)	289.6 (114.0)
2	16"-20"	165.4 (65.1)	230.4 (90.7)	172.7 (68.0)	208.3 (82.0)	274.3 (108.0)
3	11"-15"	153.4 (60.4)	218.4 (86.0)	157.5 (62.0)	195.6 (77.0)	259.1 (102.0)

SJ4A/DI3 FLOOR DIMENSIONS		
Group Size	Dim. A	Dim. B
2	177.0 (69.7)	242.3 (95.4)
3	165.4 (65.1)	230.4 (90.7)

DELTA MACHINE FRAME HEIGHT			
	Dim. D	Dim. E	Dim. G
Standard	140.46 (55.3 in.)	166.37 (65.5 in.)	235.45 (92.7 in.)
Industrial	165.86 (65.3 in.)	191.77 (75.5 in.)	260.85 (102.7 in.)
Jumbo	191.3 cm (75.3 in.)	217.2 cm (85.5 in.)	286.2 cm (112.7 in.)
XL Jumbo (DI3)	209.0 (82.3)	235.0 (92.5)	304.0 (119.7)

MACHINE SHIPPING WEIGHTS		
SJ4A/DI2 Group Size	SJ4A/DI3 Group Size	Weight Lbs./Kgs
5		5500 lbs. / 2494.75 Kgs
0		5000 lbs. / 2267.96 Kgs
1	2	4500 lbs. / 2041 Kgs
2	3	4000 lbs. / 1814 Kgs
3		3500 lbs. / 1587.57 Kgs

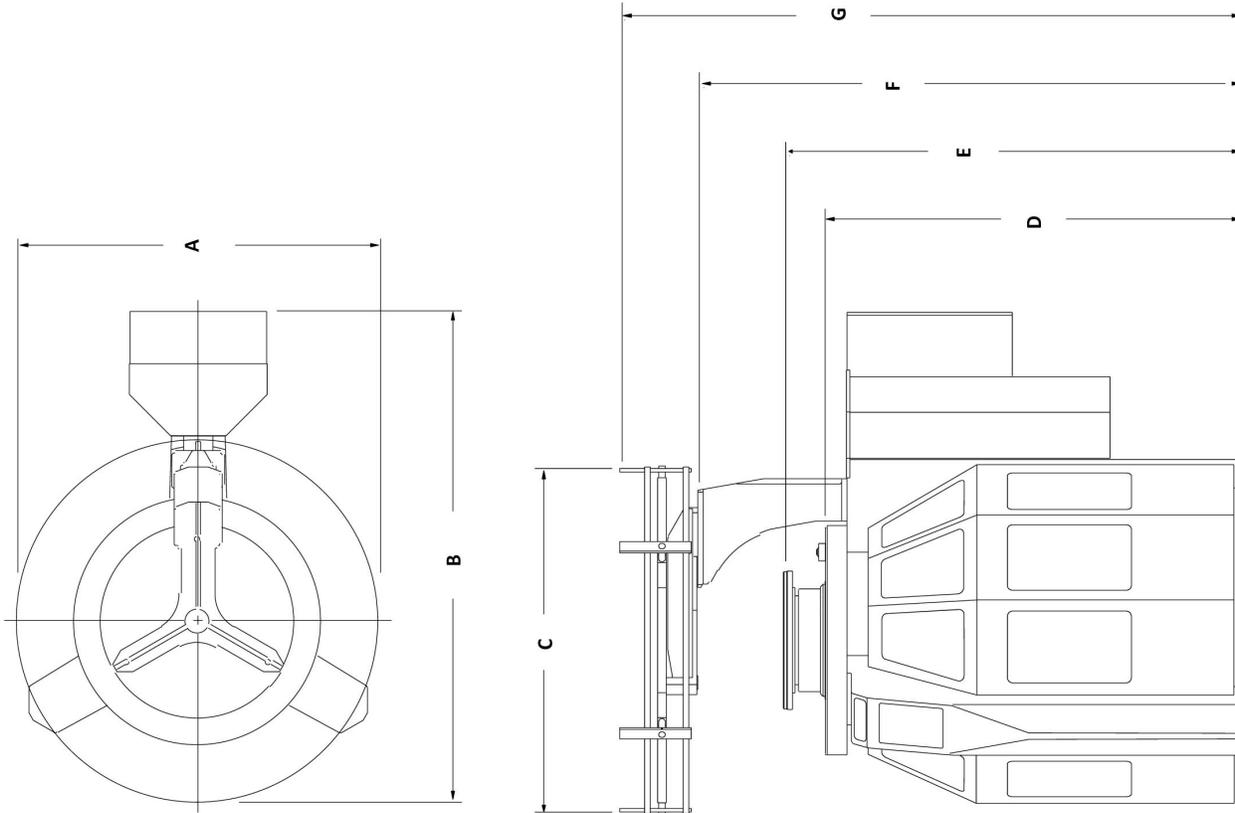

SJ4A/D, DI, DI2 AND DI3 FLOOR PLAN

Figure 31 SJ4A/D Floor Plan

DELTA GATE CIRCUIT

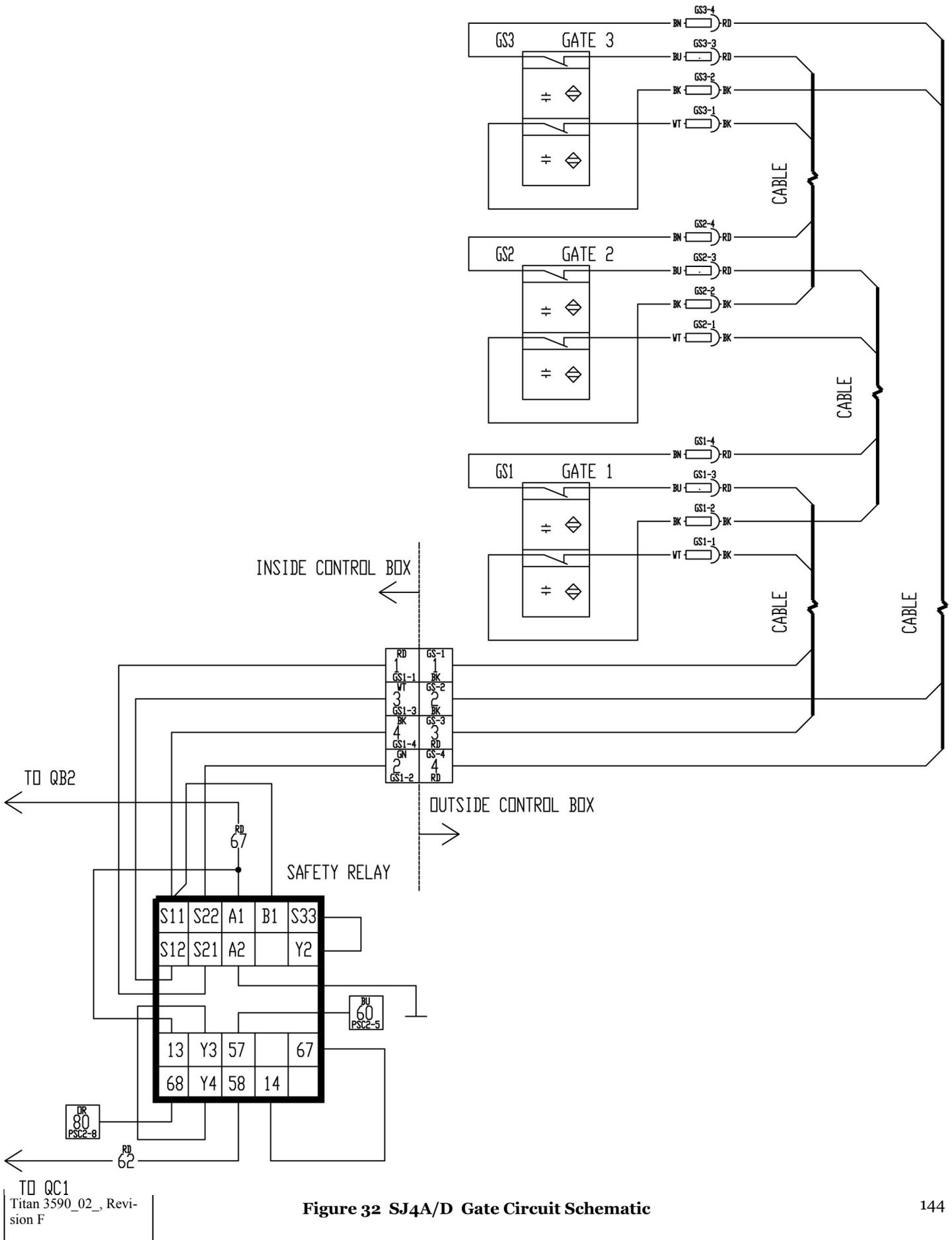
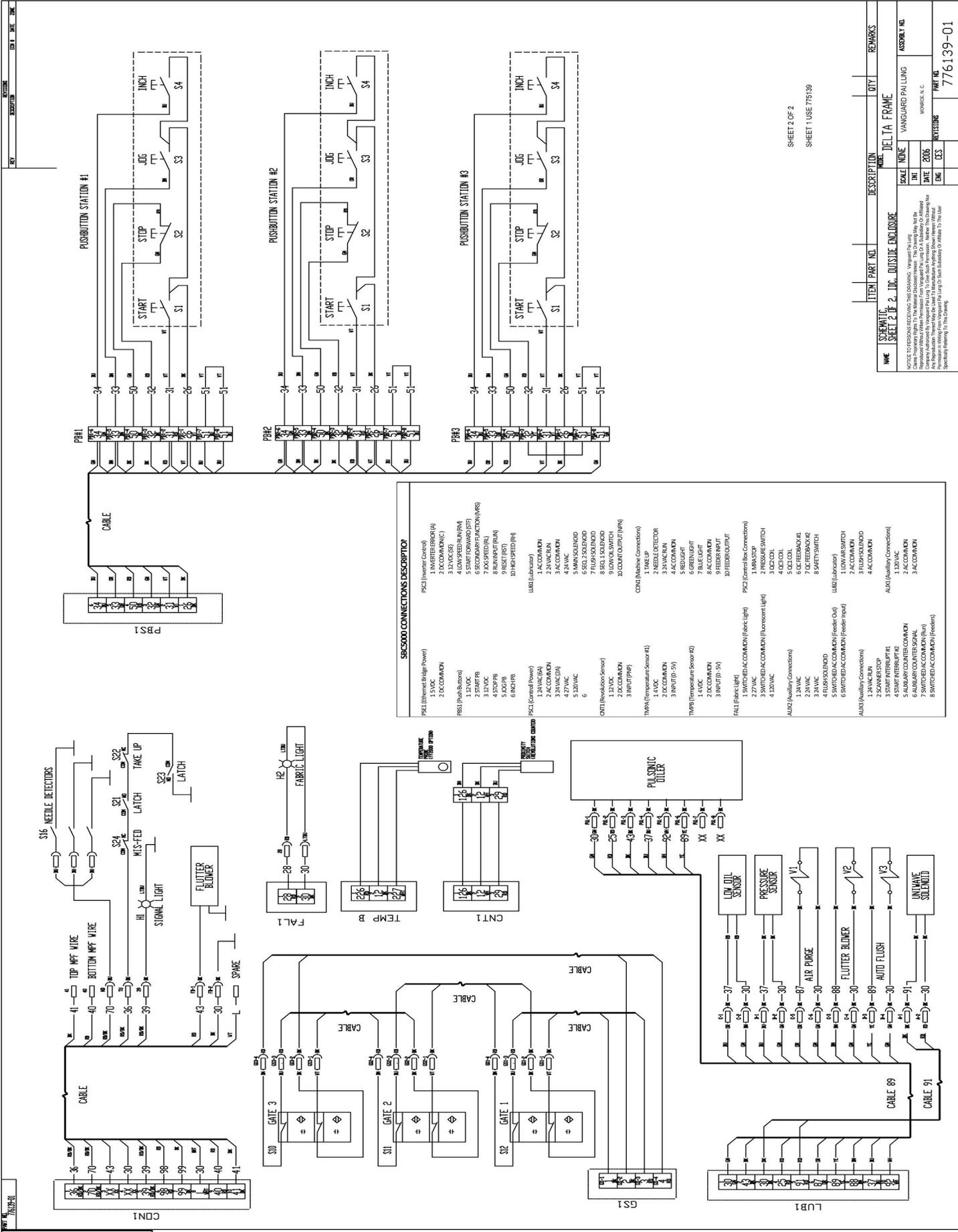

Figure 32 SJ4A/D Gate Circuit Schematic



Titan 3590_02_ Revision F

Figure 34 SJ4A/D Schematic (2 of 2)

ITEM NO.	DESCRIPTION	QTY	REMARKS
1	DELTA FRAME	1	
2	VANGUARD PULLING	1	
3	MONROE, I.L.C.	1	
4	REVISIONS		
5	DATE	2005	
6	BY	CES	
7	SCALE	NONE	
8	ASSEMBLY NO.		
9	DATE	2005	
10	BY	CES	
11	SCALE	NONE	
12	ASSEMBLY NO.		
13	DATE	2005	
14	BY	CES	
15	SCALE	NONE	
16	ASSEMBLY NO.		
17	DATE	2005	
18	BY	CES	
19	SCALE	NONE	
20	ASSEMBLY NO.		
21	DATE	2005	
22	BY	CES	
23	SCALE	NONE	
24	ASSEMBLY NO.		
25	DATE	2005	
26	BY	CES	
27	SCALE	NONE	
28	ASSEMBLY NO.		
29	DATE	2005	
30	BY	CES	
31	SCALE	NONE	
32	ASSEMBLY NO.		
33	DATE	2005	
34	BY	CES	
35	SCALE	NONE	
36	ASSEMBLY NO.		
37	DATE	2005	
38	BY	CES	
39	SCALE	NONE	
40	ASSEMBLY NO.		
41	DATE	2005	
42	BY	CES	
43	SCALE	NONE	
44	ASSEMBLY NO.		
45	DATE	2005	
46	BY	CES	
47	SCALE	NONE	
48	ASSEMBLY NO.		
49	DATE	2005	
50	BY	CES	
51	SCALE	NONE	
52	ASSEMBLY NO.		
53	DATE	2005	
54	BY	CES	
55	SCALE	NONE	
56	ASSEMBLY NO.		
57	DATE	2005	
58	BY	CES	
59	SCALE	NONE	
60	ASSEMBLY NO.		
61	DATE	2005	
62	BY	CES	
63	SCALE	NONE	
64	ASSEMBLY NO.		
65	DATE	2005	
66	BY	CES	
67	SCALE	NONE	
68	ASSEMBLY NO.		
69	DATE	2005	
70	BY	CES	
71	SCALE	NONE	
72	ASSEMBLY NO.		
73	DATE	2005	
74	BY	CES	
75	SCALE	NONE	
76	ASSEMBLY NO.		
77	DATE	2005	
78	BY	CES	
79	SCALE	NONE	
80	ASSEMBLY NO.		
81	DATE	2005	
82	BY	CES	
83	SCALE	NONE	
84	ASSEMBLY NO.		
85	DATE	2005	
86	BY	CES	
87	SCALE	NONE	
88	ASSEMBLY NO.		
89	DATE	2005	
90	BY	CES	
91	SCALE	NONE	
92	ASSEMBLY NO.		
93	DATE	2005	
94	BY	CES	
95	SCALE	NONE	
96	ASSEMBLY NO.		
97	DATE	2005	
98	BY	CES	
99	SCALE	NONE	
100	ASSEMBLY NO.		
101	DATE	2005	
102	BY	CES	
103	SCALE	NONE	
104	ASSEMBLY NO.		
105	DATE	2005	
106	BY	CES	
107	SCALE	NONE	
108	ASSEMBLY NO.		
109	DATE	2005	
110	BY	CES	
111	SCALE	NONE	
112	ASSEMBLY NO.		
113	DATE	2005	
114	BY	CES	
115	SCALE	NONE	
116	ASSEMBLY NO.		
117	DATE	2005	
118	BY	CES	
119	SCALE	NONE	
120	ASSEMBLY NO.		
121	DATE	2005	
122	BY	CES	
123	SCALE	NONE	
124	ASSEMBLY NO.		
125	DATE	2005	
126	BY	CES	
127	SCALE	NONE	
128	ASSEMBLY NO.		
129	DATE	2005	
130	BY	CES	
131	SCALE	NONE	
132	ASSEMBLY NO.		
133	DATE	2005	
134	BY	CES	
135	SCALE	NONE	
136	ASSEMBLY NO.		
137	DATE	2005	
138	BY	CES	
139	SCALE	NONE	
140	ASSEMBLY NO.		
141	DATE	2005	
142	BY	CES	
143	SCALE	NONE	
144	ASSEMBLY NO.		
145	DATE	2005	
146	BY	CES	
147	SCALE	NONE	
148	ASSEMBLY NO.		
149	DATE	2005	
150	BY	CES	
151	SCALE	NONE	
152	ASSEMBLY NO.		
153	DATE	2005	
154	BY	CES	
155	SCALE	NONE	
156	ASSEMBLY NO.		
157	DATE	2005	
158	BY	CES	
159	SCALE	NONE	
160	ASSEMBLY NO.		
161	DATE	2005	
162	BY	CES	
163	SCALE	NONE	
164	ASSEMBLY NO.		
165	DATE	2005	
166	BY	CES	
167	SCALE	NONE	
168			

Selvage line Cable harness diagram

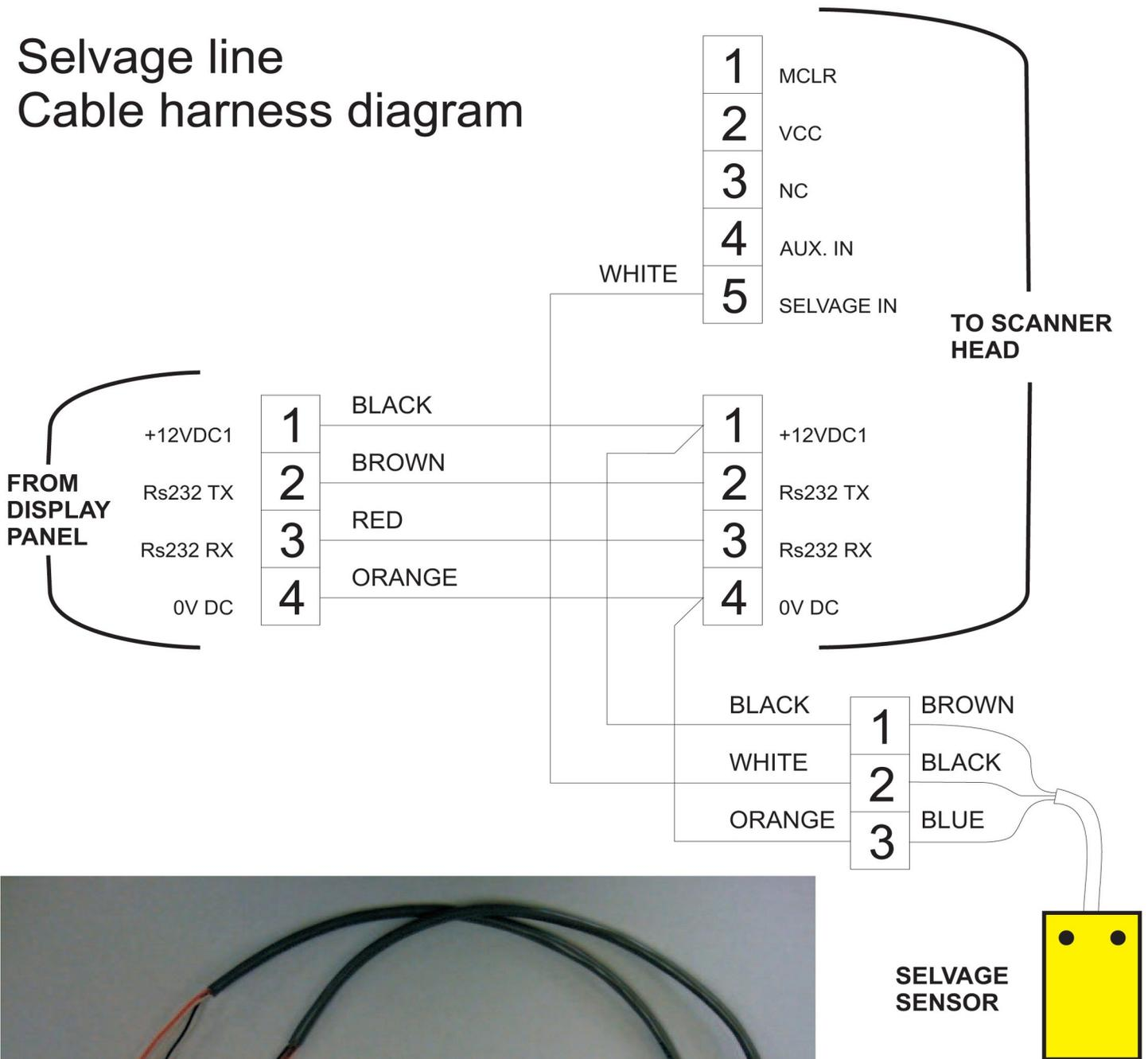

Ring Size and Feeder Belt Specifications for Delta/Titan Frame Machines

<u>(Standard Set Up) Motorized Feeder Drive</u>						
Group Size	SJ4A/DI2	SJ4A/DI3	Cotton Ring Diameter	Cotton Ring Belt Size	Lycra Ring Diameter	Lycra Ring Belt Size
GP 5	32"- 36"		88"	8400	130"	11400
GP 0	26"- 30"		80"	7800	120"	10600
GP 1	21"- 24"	16"- 20"	74"	7200	114"	10000
GP 2	16"- 20"	11"- 15"	68"	6800	108"	9600
GP 3	11"- 15"		62"	6400	102"	9200

<u>(Standard Set Up) Mechanical Quality Wheel Feeder Drive</u>						
Group Size	SJ4A/DI2	SJ4A/DI3	Cotton Ring Diameter	Cotton Ring Belt Size	Lycra Ring Diameter	Lycra Ring Belt Size
GP 5	32"- 36"		98"	9800	138"	13600
GP 0	26"- 30"		92"	9200	128"	12800
GP 1	21"- 24"	16"- 20"	88"	8800	120"	12200
GP 2	16"- 20"	11"- 15"	82"	8400	114"	11800
GP 3	11"- 15"		77"	8000	108"	11200

<u>(Staggered Ring Set Up Only) Motorized Feeder Drive</u>								
Group Size	SJ4A/DI2	SJ4A/DI3	Cotton Ring Diameter (Bottom Ring)	Cotton Ring Belt Size (Bottom Ring)	Staggered Ring Diameter (Top Ring)	Staggered Ring Belt Size (Top Ring)	Staggered Set Up: Lycra Ring Size	Staggered Set Up: Lycra Belt Size
GP 5	32"- 36"		88"	8400	103"	NOT CONFIGURED	NOT CONFIGURED	NOT CONFIGURED
GP 0	26"- 30"		80"	7800	96"			
GP 1	21"- 24"	16"- 20"	74"	7200	90"			
GP 2	16"- 20"	11"- 15"	68"	6800	82"			
GP 3	11"- 15"		62"	6400	78"			

<u>(Staggered Ring Set Up Only) Mechanical Quality Wheel Feeder Drive</u>								
Group Size	SJ4A/DI2	SJ4A/DI3	Cotton Ring Diameter (Bottom Ring)	Cotton Ring Belt Size (Bottom Ring)	Staggered Ring Diameter (Top Ring)	Staggered Ring Belt Size (Top Ring)	Staggered Set Up: Lycra Ring Size	Staggered Set Up: Lycra Belt Size
GP 5	32"- 36"		98"	9800	125"	12200	NOT CONFIGURED	NOT CONFIGURED
GP 0	26"- 30"		92"	9200	119"	11800		
GP 1	21"- 24"	16"- 20"	88"	8800	115"	11400		
GP 2	16"- 20"	11"- 15"	82"	8400	109"	11000		
GP 3	11"- 15"		77"	8000	104"	10400		

REV: 12-1-10

